

### Hole-Detector GLSL

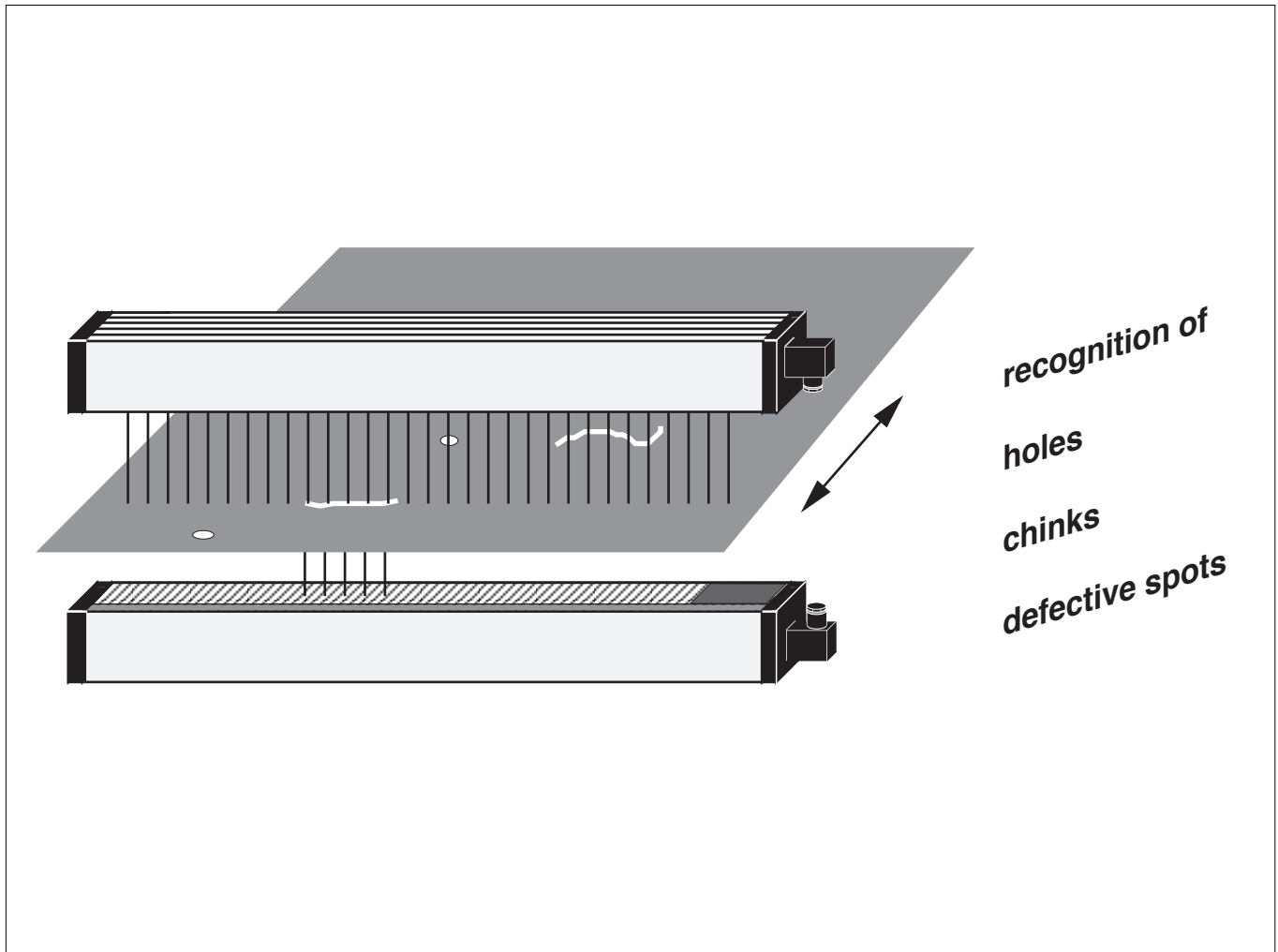

**Recognition of holes >1mm**

**Control field up to 2,8m**

**Adjustable Sensitivity**

**Compact design**

**High scanning speed**



DIN EN ISO 9001  
Reg.Nr. 96007



**Application:** Recognition of faults (holes, chinks) in metal- and plastic sheet, sheet steel band and paper web, veneer wood, etc.

**Function:** The device consists of the two components, light transmitter and light receiver.  
The **transmitter** creates an invisible, modulated infrared light band.  
The **receiver** consists of a number of optical modules, the signal amplifier and the integrated control unit. The sensitivity is adjustable, therefore the device can recognize very small holes (  $\geq 1\text{mm } \varnothing$  ). In the case of a hole, the output transistor respectively the output relay picks up and the LED "Loch erkannt" (hole recognized) lights up.

**Hole-Size:** The hole-size is adjustable between  $\geq 1\text{mm } \varnothing$  up to  $15\text{m } \varnothing$  by the potentiometer " Lochgröße " (hole size). The setting range diminishes by the increasing light transmitting capacity of the material to be controlled.

**Mode Of Operation:** Static operation:

*Material impervious to light:*

The "Static operation mode" is used mainly for material which is impervious to light.

The output switches as soon as it detects a hole which is larger than the adjusted hole size. This evaluation is carried out if there is a stop (stillstand) of the material as well.

*Transparent material:*

If the "Static operation mode" is used for material which is transparent, it is necessary to choose a different sensitivity adjustment for every change of the light transmitting capacity for recognizing the same hole-size.

Dynamic operation:

*Transparent material:*

This operation mode is **only** suitable for transparent material.

The device adapts automatically to the transparent material. By this, the device recognizes holes of the same size using the same adjusted hole-size even if the material has not the same light transmitting capacity (for example different kinds of paper). The device measures and memorizes the light transmitting capacity of the moving material. This value is used as a reference value for the sensitivity adjustment. When using this operation mode, make sure that the material to be controlled is moving. There is no evaluation during stillstand of the material!

**Technical data :**

	Light Transmitter	Light Receiver	
		Transistor Output	Relay Output
<b>Supply voltage</b>	230VAC/50 Hz op. 24VDC only for 250mm detection length	24v DC stabilized	24v DC stabilized
<b>Power consumption depending on the length of installation</b>	15 mA - 35 mA	50 mA - 200 mA	
<b>Light source</b>	GaAlAs, infrared,, 36 kHz	--	--
<b>Output</b>	--	NPN / PNP max. 100 mA short circuit proof	Relay 5 A/ 250 V, ind. free 0,2 s fall delay time
<b>Response time</b>	--	ca. 1ms	ca. 10ms
<b>Enclosure rating</b>	IP 51 (optional IP 65)		
<b>Ambient temperature</b>	-10 to +50 °C		

**Material Speed:**

The max. material speed depends on the min. hole-size.

The sensitivity is reduced with increasing band speed. Band speeds are possible up to approx. 30 m/s.

**Output:** The standard model is equipped with transistor output (PNP and NPN). A relay output is optional available. The model with transistor output has a rise time of approx. 1 ms. The model with relay output has a fall-delay time of approx. 200 ms.

**Installation:** Movable tenon blocks on the backside of the housing provide a flexible installation. The housings must be installed plane-parallel in a distance of approx. 50-100mm. Please observe that the profile remains untwisted. The material to be controlled should move in the middle between transmitter and receiver. The band has to cover the complete light field. On both sides, the band must be 15 mm wider than the light field itself. If the band is smaller, the uncovered sectors of the receiver must be covered.

**Connection Diagram:** Connection by a 6-pole plug-type connector.

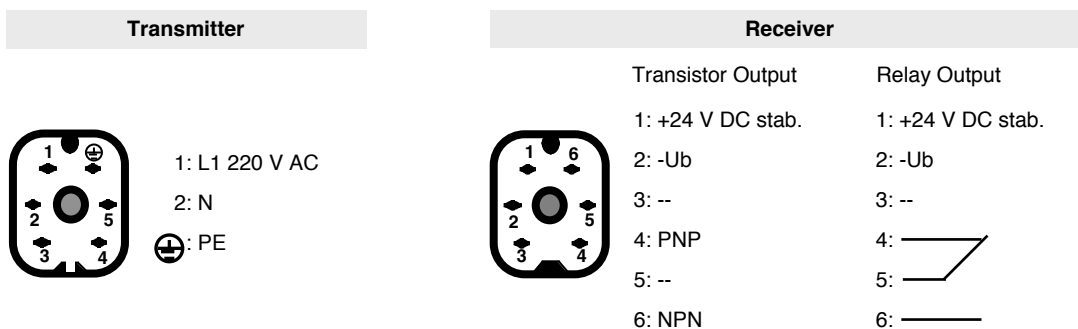

**Size:**

Type	Sensing width mm	Length L mm	Overall length mm
GLSL 250	250	334	360
GLSL 500	500	584	610
GLSL 750	750	834	860
GLSL 1000	1000	1084	1110
GLSL 1250	1250	1334	1360
GLSL 1500	1500	1584	1610
GLSL 1750	1750	1834	1860
GLSL 2000	2000	2084	2110
GLSL 2250	2250	2334	2360
GLSL 2500	2500	2584	2610
GLSL 2750	2750	2834	2860

**Dimensions:**

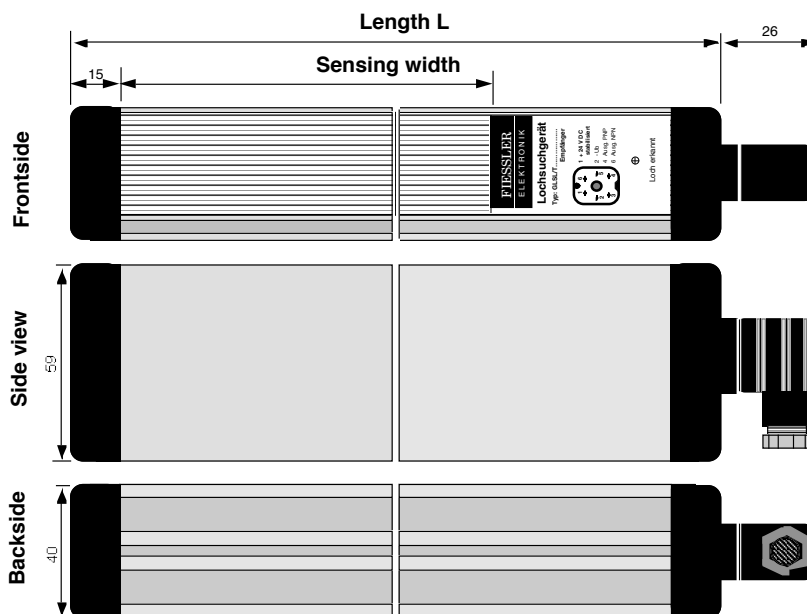

# Delivery program

Fiessler Elektronik  
 Kastellstr. 9 D-73734 Esslingen  
 Telefon: 0711 / 91 96 97-0  
 Telefax: 0711 / 91 96 97-50  
 WWW.fiessler.de  
 E-Mail: info@fiessler.de

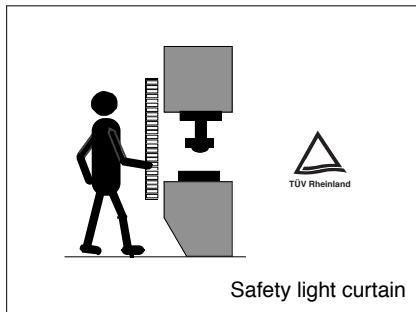

Safety light curtain

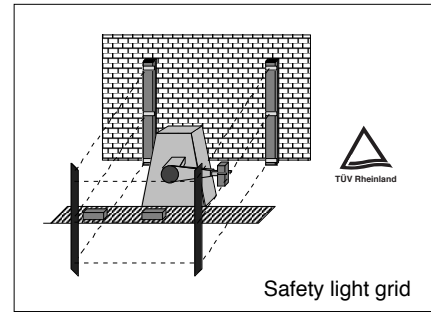

Safety light grid

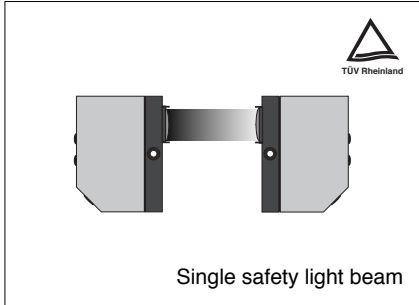

Single safety light beam

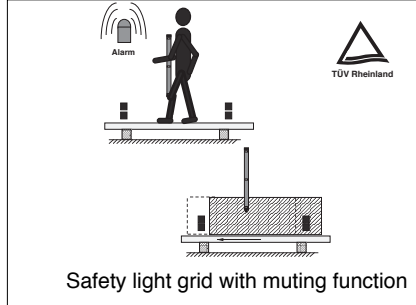

Safety light grid with muting function

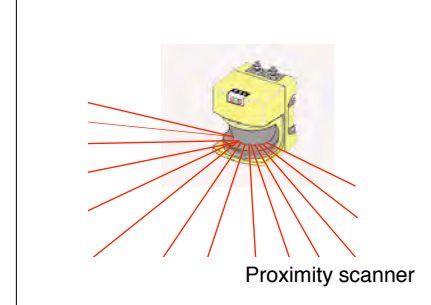

Proximity scanner

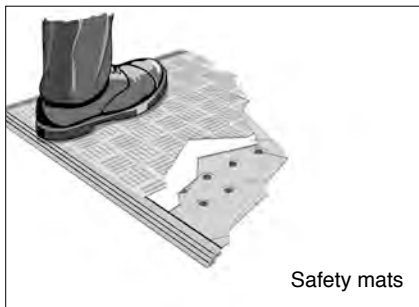

Safety mats

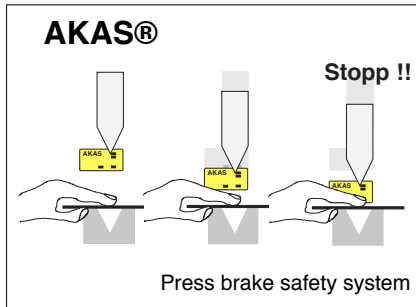

Press brake safety system

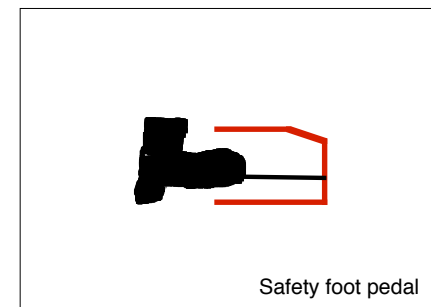

Safety foot pedal



Safety PLC  
 Safety controllers

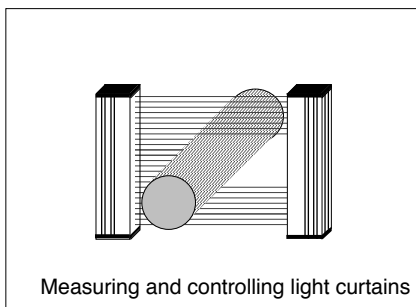

Measuring and controlling light curtains

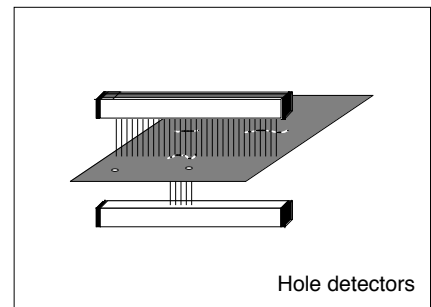

Hole detectors

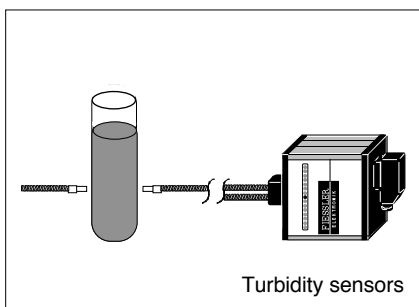

Turbidity sensors

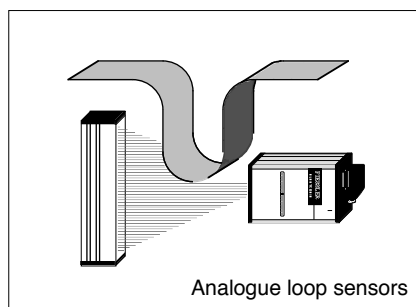

Analogue loop sensors

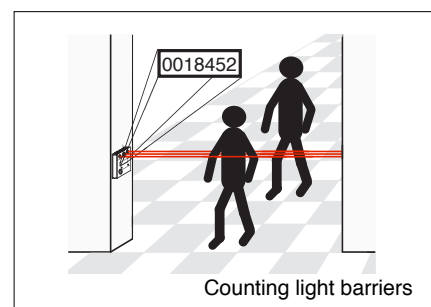

Counting light barriers

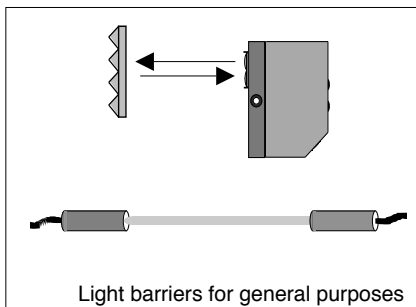
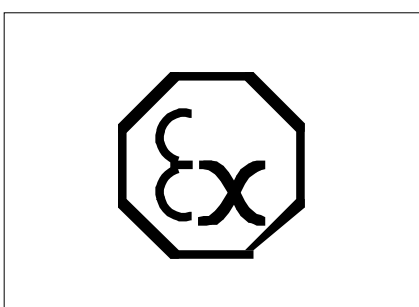

Light barriers for general purposes

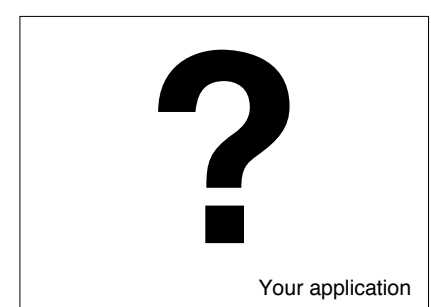

Your application