

CCD Loop detector for wires and tubes

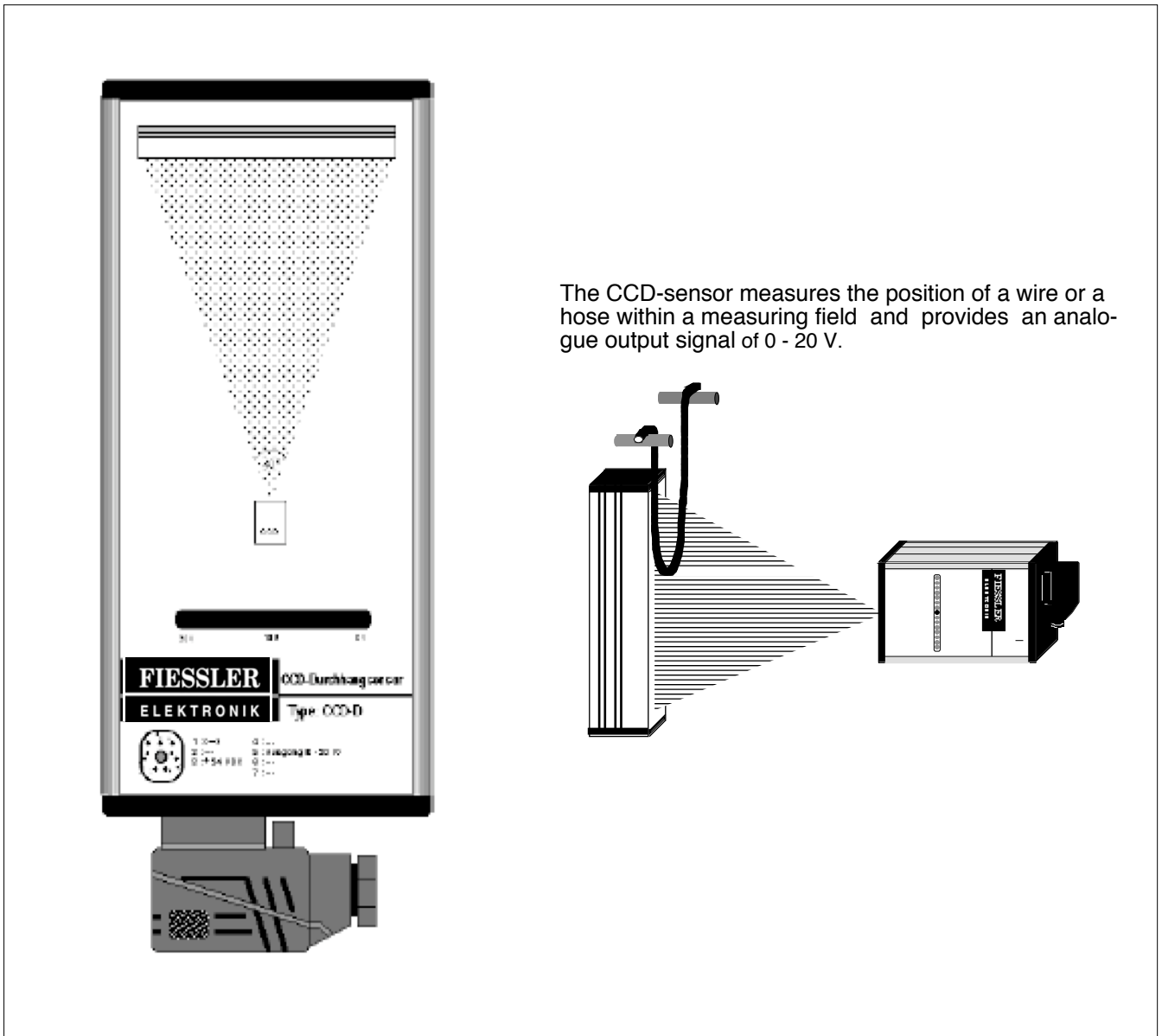

The CCD-sensor measures the position of a wire or a hose within a measuring field and provides an analogue output signal of 0 - 20 V.

Detection of wires starting from 0.3 mm Ø

Contactless, optoelectronic measurement principle

High accuracy by CCD - line

Visual readout of measurements provided by a row of LEDs

Automatic contrast alignment

Universal fastening by tenon blocks



DIN EN ISO 9001
Reg.Nr. 96007



Application:

Loop control systems are used as a speed control for two or more machines that are installed in a row. For keeping constant the loop of a wire or a hose, very frequently a dual-mode control is not sufficient. The analogue loop-detector transmits an input signal to the variable speed drive. Therefore, a constant loop control and loop shape is enabled. The analogue loop-detector measures the loop of a wire or hose. The signal provided is proportional to the position of the wire or hose. By this, a constant constant loop shape is enabled.

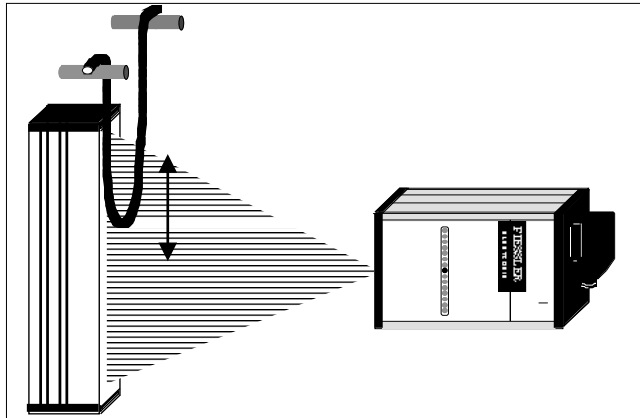

CCD - transmitter:

The light transmitter is equipped with high frequency operated, fluorescent tube for producing a homogeneous light field.

CCD - receiver:

The receiver-optic displays the lightband of the transmitter on a CCD line with 2048 elements. These elements are periodically queried. If no object is present within the measuring field, all elements are lit up. The output voltage is 0 V. If one or several of these receiver diodes is blocked by an object, the circuit detects which of the diodes do not receive light. The output supplies an output voltage of 0 - 20 V according to the situation of this shading.

The upper edge of the wire is the determining factor. The measuring signal is visualized by a row of LEDs.

Control unit:

The following power supply is available :

NG 300: 24 V DC stabilized, max 300 mA

Technical data:

Distance (transmitter - receiver)	Transmitter type	Hight of measuring field	max. resolution (wire Ø)
100 mm	CCD - S 235	65 mm	0,3 mm
200 mm	CCD - S 235	125 mm	0,6 mm
400 mm	CCD - S 355	250 mm	1,2 mm
600 mm	CCD - S 505	385 mm	1,8 mm
800 mm	CCD - S 685	490 mm	2,5 mm
1000 mm	CCD - S 895	615 mm	3,0 mm

The highest resolution with full measuring field height is reached, if the wire is placed directly in front of the light transmitter.

	CCD - D - receiver	CCD - transmitter:
Supply voltage:	24 V DC stabilized	230 V AC ± 5 %
Power consumption:	ca. 100 mA	ca. 200 mA
Output voltage:	0 - 20 V	-----
Ambient temperature:	- 10°C bis 50°C	- 10°C bis 50°C
Connection:	plug-type connector with screws	
Housing:	Aluprofile, anodized with plastic screens	

For an optimum adaptation to the different operating conditions, special designs are possible and available on request. With low expenditure, ranges, enclosure ratings and output voltages can be changed according to your requirement.

Connection:

The connection must be made according to the diagram which is printed on the CCD-D receiver front panel. The symbols have the following meanings:

connector CCD - D - receiver

1	=	(-)
2	=	PE
3	=	+ 24 V DC stab.
4	=	free
5	=	output (0 - 20 V)
6	=	free
7	=	free

connector CCD - transmitter

1	=	L1 230 V AC ± 5 %
2	=	N
⊕	=	PE

Mechanical adjustment:

Adjust the transmitter and receiver in a way that both are located plane-parallel on the same center axis, and that they are mounted with the correct distance to each other.

Transmitter and receiver are equipped with tenon blocks and mounting plates. The mounting plates are slidable and can be mounted on three sides of the housing.

Electric adjustment:

To adjust the receiver a digital voltmeter has to be connected between terminals 1 and 5.

The receiver has to be aligned in a way that in the LED row only the 0V LED lights up and the digital voltmeter indicates an output voltage of approx. 0.05 V DC.

The transmitter should be switched on approx. 2 min. prior to the start of the adjustment, as otherwise no homogeneous light field is produced.

Dimensions:

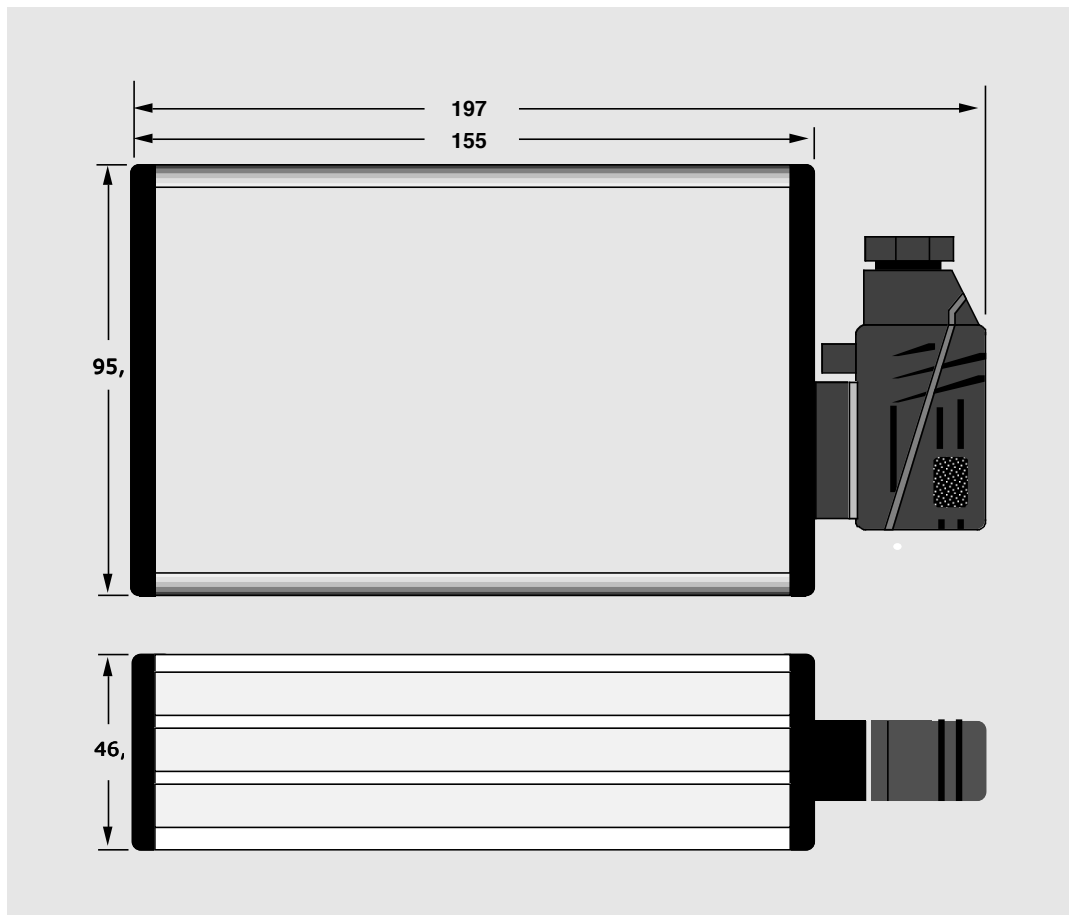

Delivery program

Fiessler Elektronik
 Kastellstr. 9 D-73734 Esslingen
 Telefon: 0711 / 91 96 97-0
 Telefax: 0711 / 91 96 97-50
 WWW.fiessler.de
 E-Mail: info@fiessler.de

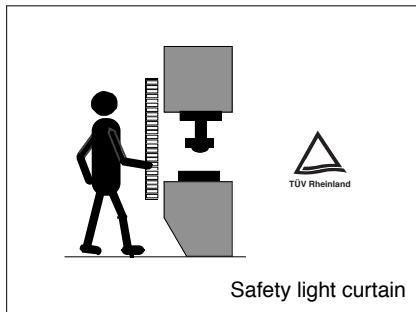

Safety light curtain

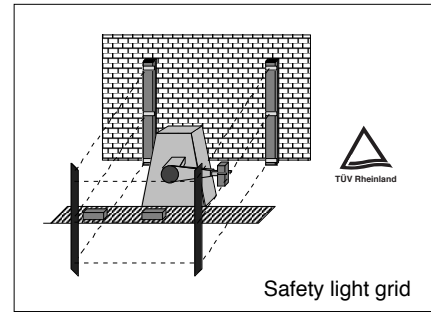

Safety light grid

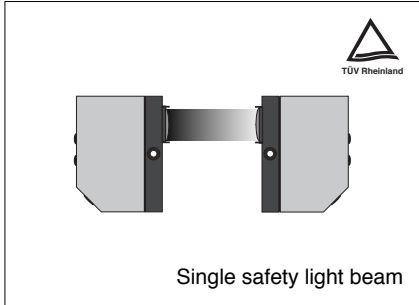

Single safety light beam

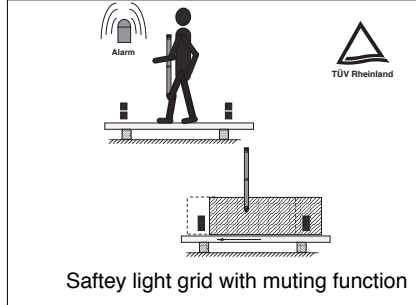

Safety light grid with muting function

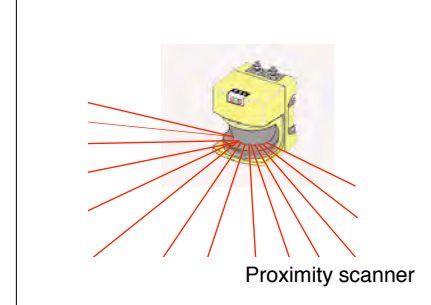

Proximity scanner

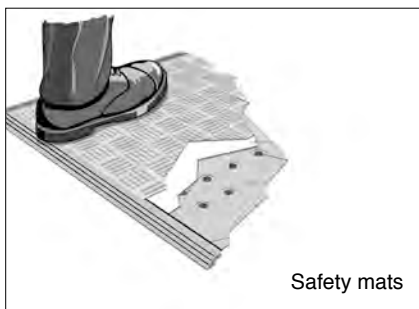

Safety mats

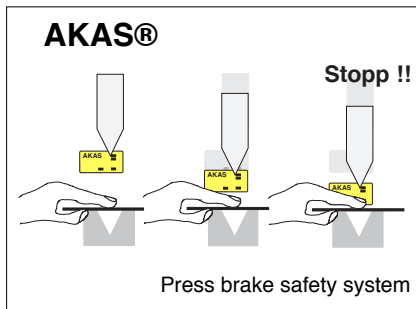

Press brake safety system

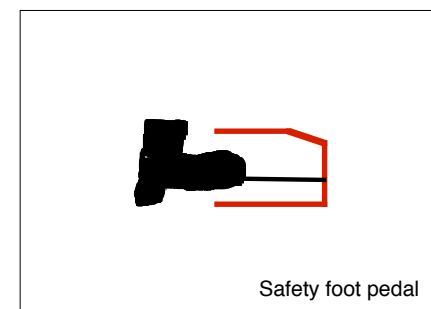

Safety foot pedal

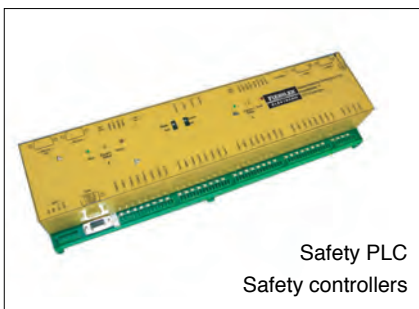

Safety PLC
 Safety controllers

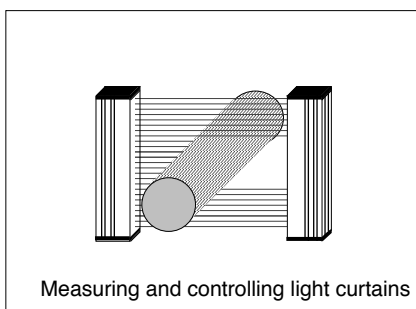

Measuring and controlling light curtains

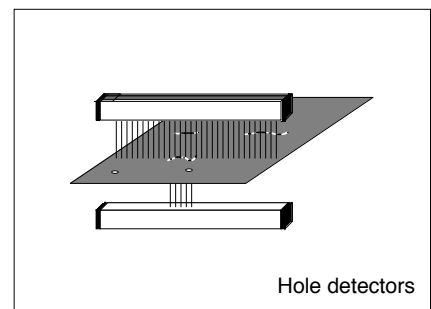

Hole detectors

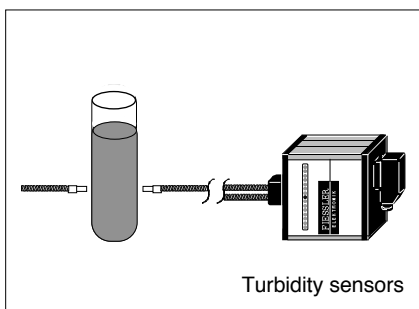

Turbidity sensors

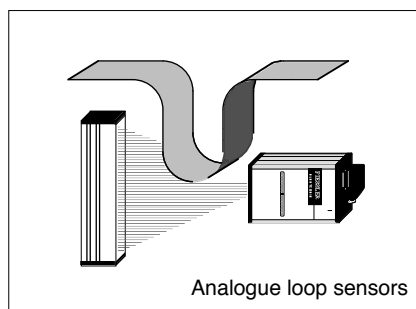

Analogue loop sensors

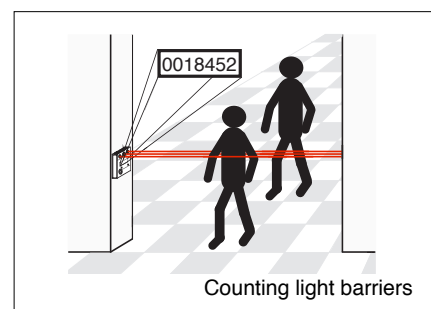

Counting light barriers

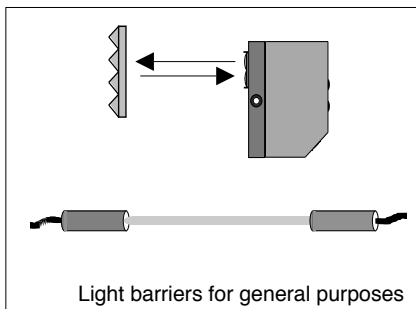
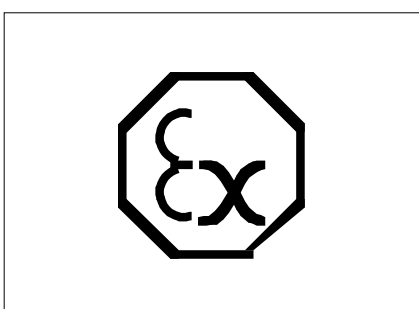

Light barriers for general purposes

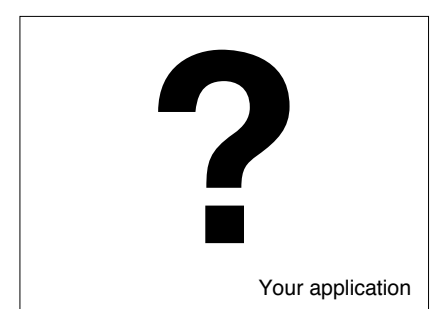

Your application