

FISSLER

ELEKTRONIK

Type 2 safety light curtains

TLCT

ILCT

Operating manual

translation

**Nicht mehr
!Lieferbar!**

no longer

!available!

CONTENTS:

Safety notes

Application notes

Assembly

Electrical connections

Commissioning

Technical data

Accessories



- Safety category 2
(EN 954-1 and IEC 61496 Part1 + Part2 or EN 61496)
- Deployable to SIL 1 (EN 61508)
- Performance Level PL c (ISO 13849-1)

BA - TLCT_ILCT_GB Dok 1129 Stand 23.4.2013 / RK / AuI

For over 50 years,
we have specialized in the area of
opto-electronics.

Our experience is your gain.

Tell us your problems and we will
be pleased to advise you.

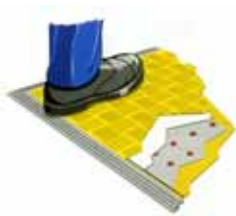

Footmats

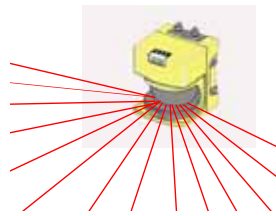

Laser scanners

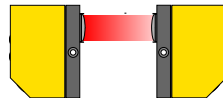

Single-beam safety light
barriers with a long range
(up to 150 m)



Press brake protection sy-
stem AKAS®

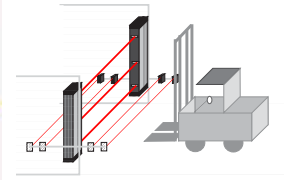

Differentiation between
humans and machines by
muting function

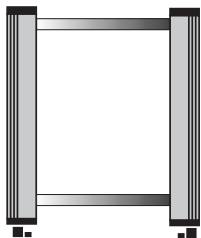

Two-beam light grids with a
range of up to 60 m

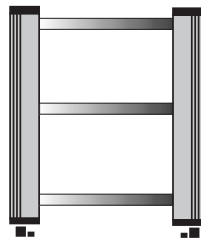

Three- or more beam light
grids with a range of up to
60 m

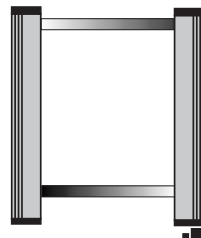

Two-beam light grids with
transmitter / receiver units
and a deflecting mirror with
a range of up to 10 m

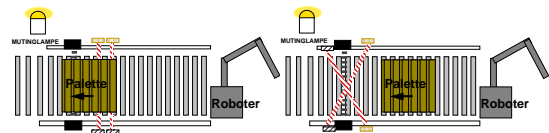

Output muting
Differentiation between
humans and material

Cross-muting
Differentiation between
humans and material /
machines

Fiessler Elektronik GmbH & Co. KG
Kastellstr. 9
D-73734 Esslingen

Phone: ++49(0)711-91 96 97-0
Fax: ++49(0)711-91 96 97-50
E-Mail: info@fiessler.de
Internet: www.fiessler.de

Represented in all major countries



We also invest in environmental safety

Chapter	Contents	Page
1	System Description and Technical Data	4
1.1	Features and areas of application	4
1.2	Design and function	5
1.3	Overview: Protective field height, lengths, ranges, resolutions and beam count	5
1.4	LEDs and displays / Display on interruption of a light beam	6
1.5	Indication and change of operating mode /preset operating mode	7
1.6	Fault diagnosis	8
1.7	Technical data	9
1.8	Dimensions	10
2	Assembly	11
2.1	Reaction times	11
2.2	Safety clearances to hazard zones	12-13
2.3	Installation conditions	14-16
2.4	Mounting and adjustment	17
	Swivel mounting	17-19
	Optional mountings	20
	Multi-sided safeguarding via deflecting mirrors – optional	21
3	Electrical connection	22
3.1	Receiver's connecting plug	22
3.2	Connection with restart interlock / with contactor control	22
3.3	Connection without restart interlock / without contactor control	22
3.4	Transmitter's connecting plug	22
4	Safety notes 	23
5	Auxiliary functions with safety switchgear	24
6	Blanking functions only for ILCT	25-29
7	Cascaded light grids only for ...LCT-K	30-34
8	Definition of terms	35-36
9	Accessories and spare parts	37
10	Order codes	38
11	Service / Maintenance / Warranty	39

Features:

- **Safety category 2** (EN 954-1 and IEC 61496 Part1 + Part2 or EN 61496);
deployable to SIL 1 (EN 61508)
Performance Level PL c (ISO 13849-1)
- **User-friendly self-testing:** required no external cyclic system test.
- **Contactor control and restart interlock**
Integrated functions can be programmed without a PC
- **Directly controllable contactors / valves**
Switching capacity: 0.5 A / 24 V
- **Beam spacing:** 8.33 mm, 25 mm (resolution: 14 mm, 30 mm)
- **Protective field widths** (range): 5 m
- **Protective field heights:** 100 mm - 1500 mm
- **Short reaction times:** 4 ms to 29 ms depending on the length; correspondingly short safety clearances
- **Semiconductor outputs** with short-circuit and cross-connection monitoring
- **11 different blanking patterns** (ILCT only). Blanking of obstacles with reliable safety.
- **cascading:** for protecting a hazardous area on more than one side, up to three light curtains may be connected in series.

Areas of application:

Safeguarding of hazard zones

Barricading of sectors

Protection of fingers and hands, e.g. when operating:

- Presses for wood, wood working machines
- Packaging machines
- Textile Machinery
- Injection moulding machines
- Round-stroke engines (revolving machines)
- storing and materials-handling technology
- Automatic placement machines
- Palleting machines

Mirrors can be used to deflect a protective field around hazard zones, permitting creation of multi-sided barricades.

Optional safety switchgears permit muting and clocked operation (refer to Chapter 5).

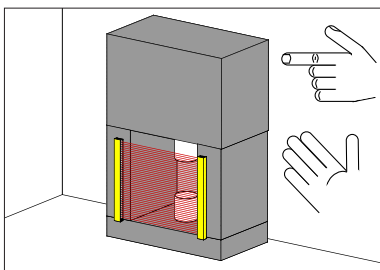

Fig. 4/1: Safeguarding of hazard zones

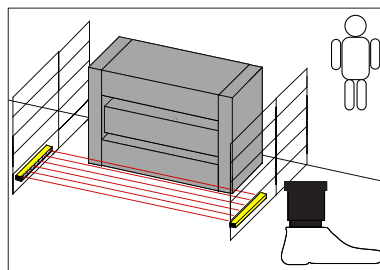

Fig. 4/2: Barricading of sectors

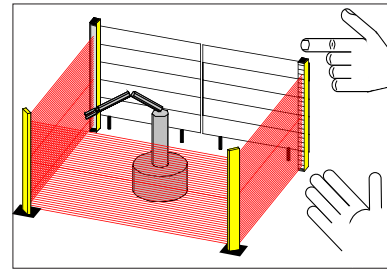

Fig. 4/3: Barricading of access areas by means of deflecting mirrors

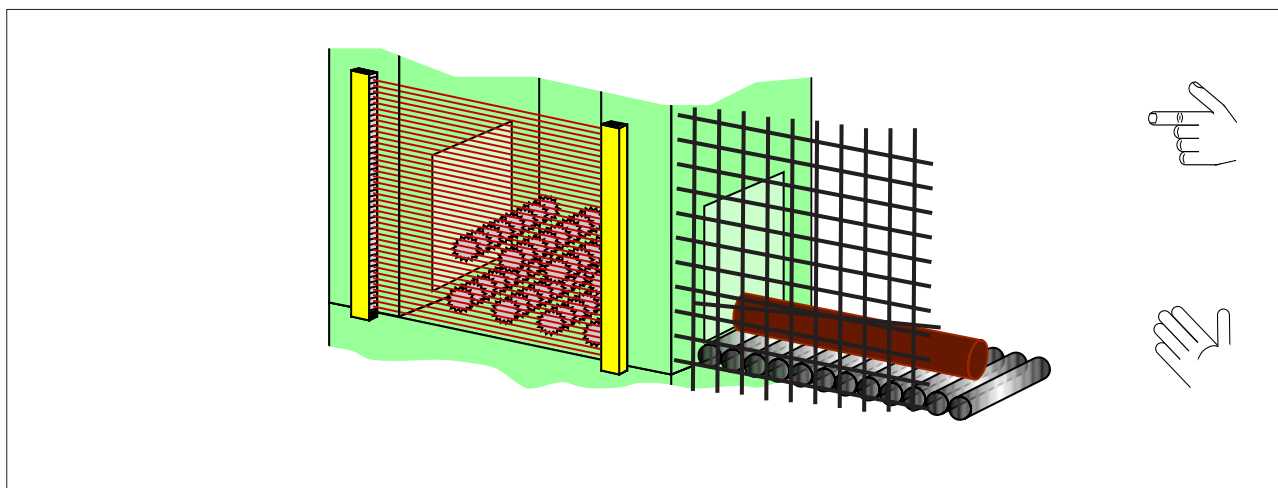

Fig. 4/4: Safeguarding of hazard zones

Design and function

TLCT/ILCT safety light curtains each comprise two components: Light transmitter and light receiver. The clearance between these two components and the installation height determine the width and height of the protective field (Figure 5/1).

Modular design permits realization of protective field heights ranging from 100 mm to 1500 mm in 100-mm steps.

The transmitter generates infrared light beams in rapid pulses. These parallel light beams are analyzed by two single-chip controllers in the transmitter. The beam spacing determines the resolution (refer to Table 5/2).

If an object enters the protective field, i.e. if at least one light beam is interrupted, the receiver's two outputs stop the machine or prevent it from starting, thus avoiding hazards.

In the restart with interlock operating mode, the machine can only be restarted by means of the start button once the protective field has been cleared again.

User-friendly self-testing: The customary testable category 2 light curtains required a external cyclic system test. With TLCT light curtains this is no longer necessary, because a continuous internal self-testing is active.

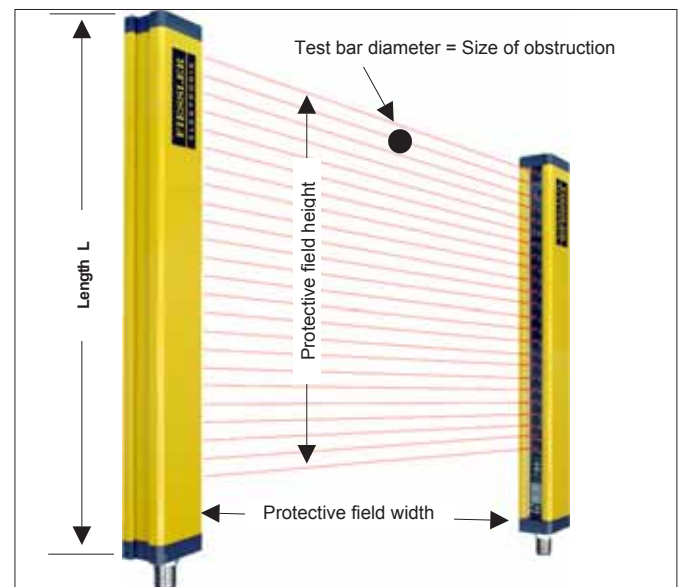

Fig. 5/1: The transmitter and receiver together generate a protective field.

Protective field heights, lengths, ranges, resolutions and beam count

Overview table		TLCT / ILCT	TLCT
		Finger protection Resolution: 14 mm	Hand protection Resolution: 30 mm
		Range: 5 m	Range 5 m
Protective field height (mm)	Length L (mm)	Beam count	Beam count
100	161	12	4
200	261	24	8
300	361	36	12
400	461	48	16
500	561	60	20
600	661	72	24
700	761	84	28
800	861	96	32
900	961	108	36
1000	1061	120	40
1100	1161	132	44
1200	1261	144	48
1300	1361	156	52
1400	1461	168	56
1500	1561	180	60

Table 5/2: Overview of standard light grids

LEDs and displays

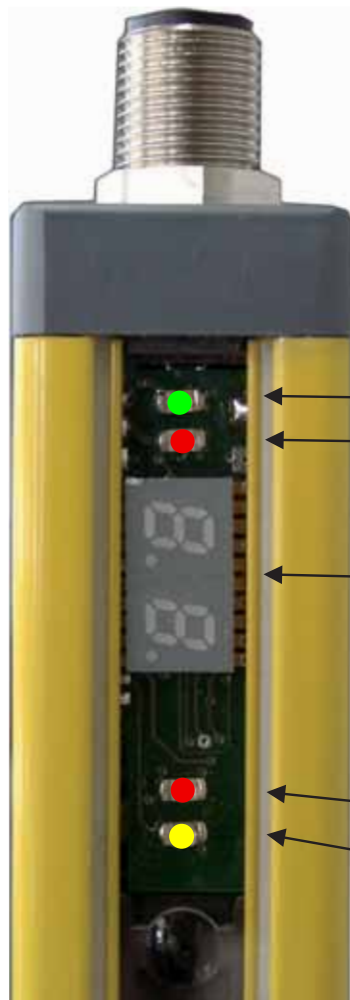

The LEDs and display on the receiver indicate the current operating status.

- ← Outputs (OSSDs) active green LED comes on when the outputs are energized.
- ← Outputs (OSSDs) inactive red LED comes on when the outputs are de-energized.
- ← - Indication of operating mode for about 2 seconds during power-on.
- ← - Indication of the uppermost [see below](#)
interrupted light
- ← - Error diagnosis [refer to the chapter on error diagnosis](#)
- ← Adjustment aid and light reserves .. red LED comes on when light reserves have dropped.
- ← Restart interlock in the operating mode with restart interlock, the yellow LED comes on when the protective field is clear and the start button is ready for operation.

Display on interruption of a light beam

If one or more light beams are interrupted, the number of the uppermost interrupted beam (as seen from the connecting plug) is displayed.

On light grids comprising more than 99 light beams, the right-hand decimal point also shines if the 122nd beam is interrupted, for instance. If a light beam numbered higher than 200 is interrupted, both decimal points shine.

If the synchronous eye is interrupted (1st light beam as seen from the connecting plug), "0 0" flashes on the display.



23rd light beam is interrupted.



122nd light beam is interrupted.

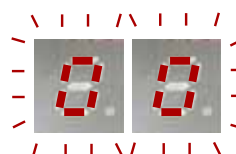

1st light beam is interrupted.

Indication of operating mode

The stored operating mode is indicated for about 2 seconds during power-on.



"E A" = **with** EDM (contactor control) / **with** restart interlock (setting on delivery)



"E -" = **with** EDM (contactor control) / **without** restart interlock



"- A" = **without** EDM (contactor control) / **with** restart interlock



"- -" = **without** EDM (contactor control) / **without** restart interlock

Changing the operating mode

To change the operating mode you have to disconnect the power supply. Then bridge the **OSSD2** (6) output with **+UB** (2) input and connect a button between the **Start** (1) input and **+UB** (2) input .

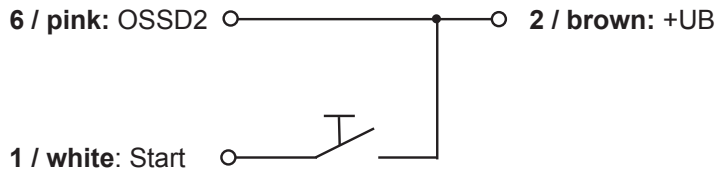

The button at the **Start** input must be actuated during power-on. "L L" flashes on the display.

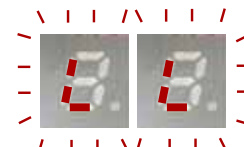

The button at the **Start** input must remains on (min. 2s), until the actual operating mode from the device flashes on the display. You can then release the button.

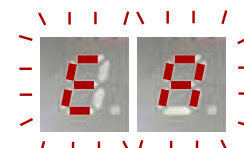

To select a new operating mode, briefly press the button once again; the selected mode flashes on the display. Each time you shortly press the button, the next operating mode is called up.



If you hold down the button for 2 seconds or longer, the currently displayed operating mode is saved and remains solidly lit on the display.



This procedure (brief actuation of the button) can be repeated as often as necessary. After you have removed the bridge between OSSD2 and +UB and reset the voltage, the saved operating mode becomes effective.

Fault diagnosis

If the light grid detects a faulty connection or an internal error, the **adjustment-aid and restart-interlock LEDs flash** together with the corresponding error code on the **display**.



F1 = Incorrect start line

Operating mode with restart interlock: Start input is bridged to +24 VDC.
 Operating mode without restart interlock: Bridge from start input to +24 VDC is missing.



F2 = Incorrect EDM line

Operating mode with EDM: The contactors are not released or the EDM input is bridged to +24 VDC.
 Operating mode without EDM: Bridge from EDM input to +24 VDC is missing.



F3 = External transmitter detected

A second light transmitter has been detected in the receiver's range. To preclude mutual interference between adjacent light curtains, neighbouring systems must be installed in accordance with the [instructions on Page 16](#).



F4 = Error during change of operating mode

The start button was held down too briefly for changing the operating mode during power-on. Or the bridge from OSSD2 to +24 VDC was detached during a change of operating mode (refer to the section on [changing operating modes on Page 7](#)).



F5 = Internal error

Power-on the device once again. If **F5** is still displayed, an internal error has occurred. In this case, the device must be sent in for repair.



F6 = OSSD error

Short-circuit between one or both OSSDs and +24V, or between the OSSDs.



No start possible despite clear light path (display off):

In the operating mode with restart interlock, if the yellow LED does not shine despite intact light beams and the adjustment aid LED is off, it means that the contactors are not released.

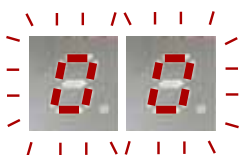

Flashing:
 1st light beam is interrupted.



Not flashing:
 No blanking (only for ILCT)

Technical data



Characteristic data	TLCT... / ILCT...	
Safety category	Type 2 according to EN 954-1 and IEC 61496 Part 1 + Part 2 or EN 61496 Part 1 + Part 2; deployable to SIL 1 (EN 61508) ¹ ; category 2 PL c (ISO 13849-1) ¹	
Protective field height	100 mm ... 1500 mm	
Protective field width (max. range)	0 ... 5 m	
Resolution	Smallest detectable obstruction size of 14 mm or 30 mm	
Reaction time	4 ms to 29 ms depending on the length and type; correspondingly short safety clearances	
Self-diagnosis	Microcontroller monitoring of safety functions (self-monitoring) 7-segment fault display	
Operating modes (programmable without a PC, Page 7)	- With / without restart interlock - With / without contactor control (EDM)	
Mechanical data		
Mountings	- Pivot-joint holder on the light barrier's upper and lower sides for fine adjustment - Movable shackles with adjustment screws on the housing's rear (optional) - Flexible T-slot (optional)	
Housing design	Aluminium profile, 25 x 35 mm, plastic coating, RAL 1021 (yellow). End-pieces comprise acid-resistant plastic (polyamide) reinforced with glass beads. Plexiglass for light entry and exit.	
Operating data		
Protection type	IP 65	
Protection class	III	
Ambient operating temperature	-10 to 50 °C	
Storage temperature	-25 to 70 °C	
Electrical data	Transmitter TLCT-S / ILCT-S	Receiver TLCT-E / ILCT-E
Supply voltage²	24 V DC + 20 % - 15 % SELF, PELF	24 V DC ± 20% SELF, PELF
Current consumption	Max. 250 mA	Max. 250 mA (without load)
Outputs	-	OSSD 1 and 2: Fail-safe PNP outputs with short-circuit and cross-connection monitoring. Output current: min. 0 mA: max. 0.5 A Max. output current in the inactive state: 50 µA Max. voltage in the inactive state: 0.9 V Max. capacitive load: 1 µF
Inputs	-	Contactor control (EDM) and start button 0 V to 24 V DC ± 20 %, max. 5 mA
Electrical connection	M12 plug connector, 4-pole	M12 plug connector, 8-pole

1 Contact us directly for details on how to precisely tailor systems to your requirements.

2 The external voltage supply must be capable of bridging brief mains failures of up to 20 ms according to EN 60 204-1. We offer suitable power supply units as accessories.

Light curtain dimensions

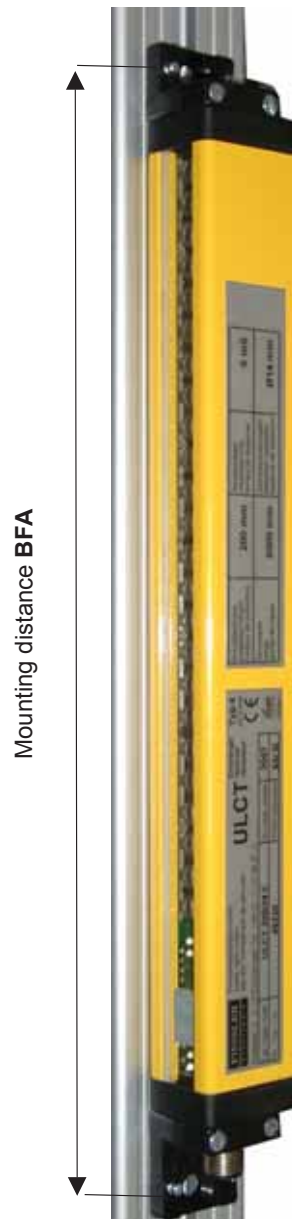
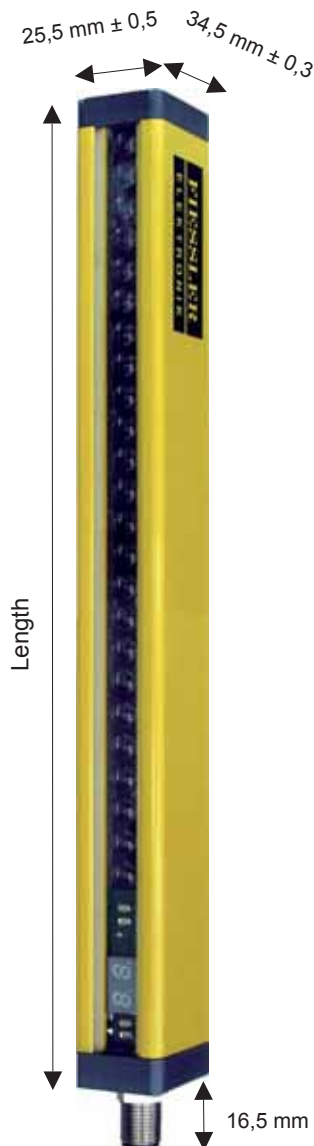

Housing design:

Aluminium profile, plastic-coated RAL 1021, yellow end-pieces comprising acid-resistant plastic (polyamide) reinforced with glass beads. Plexiglass for light entry and exit.

Mounting:

Swivel holder or optional, movable shackles on the rear of the housing

Protective field height (mm)	Length (mm)	Mounting distance BFA (mm)
100	162	200
200	262	300
300	362	400
400	462	500
500	562	600
600	662	700
700	762	800
800	862	900
900	962	1000
1000	1062	1100
1100	1162	1200
1200	1262	1300
1300	1362	1400
1400	1462	1500
1500	1562	1600

Reaction time

The time which elapses between penetration of the protective field and deactivation.

In the case of the TLCT / ILCT light grids, the protective mechanism's reaction time t_1 depends on the beam count.

TLCT / 14 mm resolution			
System	Protective field height (mm)	Beam count	Reaction time (ms)
TLCT 100/12	100	12	5
TLCT 200/24	200	24	6
TLCT 300/36	300	36	7
TLCT 400/48	400	48	8
TLCT 500/60	500	60	9
TLCT 600/72	600	72	10
TLCT 700/84	700	84	11
TLCT 800/96	800	96	12
TLCT 900/108	900	108	13
TLCT 1000/120	1000	120	14
TLCT 1100/132	1100	132	15
TLCT 1200/144	1200	144	17
TLCT 1300/156	1300	156	18
TLCT 1400/168	1400	168	19
TLCT 1500/180	1500	180	20

ILCT / 14 mm resolution			
System	Protective field height (mm)	Beam count	Reaction time (ms)
ILCT 100/12	100	12	7
ILCT 200/24	200	24	9
ILCT 300/36	300	36	10
ILCT 400/48	400	48	12
ILCT 500/60	500	60	14
ILCT 600/72	600	72	15
ILCT 700/84	700	84	16
ILCT 800/96	800	96	18
ILCT 900/108	900	108	20
ILCT 1000/120	1000	120	21
ILCT 1100/132	1100	132	22
ILCT 1200/144	1200	144	24
ILCT 1300/156	1300	156	25
ILCT 1400/168	1400	168	27
ILCT 1500/180	1500	180	29

TLCT / 30 mm resolution			
System	Protective field height (mm)	Beam count	Reaction time (ms)
TLCT 100/4	100	4	4
TLCT 200/8	200	8	5
TLCT 300/12	300	12	5
TLCT 400/16	400	16	6
TLCT 500/20	500	20	6
TLCT 600/24	600	24	7
TLCT 700/28	700	28	7
TLCT 800/32	800	32	7
TLCT 900/36	900	36	8
TLCT 1000/40	1000	40	8
TLCT 1100/44	1100	44	8
TLCT 1200/48	1200	48	9
TLCT 1300/52	1300	52	9
TLCT 1400/56	1400	56	10
TLCT 1500/60	1500	60	10

Cascaded light grid	
Examples	Reaction time (ms)
Main sensor TLCTK 800/12	9 ms
Secondary sensor 1 TLCTK 500/20	Intrinsic reaction time + 3 ms 6 ms + 3 ms = 9 ms
Secondary sensor 2 TLCT 800/32	Intrinsic reaction time + 6 ms 12 ms + 6 ms = 18 ms

Optional safety switchgear	
Type	Reaction time (ms)
PLSG 1K (muting controller)	3,5
PLSG 2K (muting controller)	3,5
PLSG 3K (muting and universal controller)	3,5
ULSG (switching device)	6
BPSG (ILCT programming and switching device)	6

Safety clearance to hazard zones (EN 999 / ISO 13855)



The clearance S between the safety light curtain and the hazard zones must be large enough to stop the machine before any of its components can reach a hazard zone following penetration of the protective field.

Additional mechanical barriers and light curtains must be installed to prevent access over, under, around and behind the protective field. In this context, also refer to EN 999 / ISO 13855 and other relevant national / international safety regulations.

Vertical safeguarding of hazard zones with light curtains

(valid to a resolution of 40 mm)

The safety clearance S is calculated as follows:

$$S = (K \times T) + C$$

K = Gripping or approach speed

The gripping speed K is assumed as being 2000 mm/s. If a value of more than 500 mm is calculated for S , the calculation can be repeated with 1600 mm/s provided that the result for S here is at least 500. ($S \text{ min} \geq 100 \text{ mm}$)

$T = t_1 + t_2$

t_1 = Protective mechanism's reaction time

In the case of the TLCT / ILCT light curtains, the protective mechanism's reaction time t_1 depends on the beam count (see the table on Page 11).

If optional safety switching devices are used, the the reaction times stated next are added to the reaction time t_1 :

PLSG: 3,5 ms

ULSG / BPSG: 6 ms.

t_2 = Machine's run-on time

The machine's run-on time t_2 must be specified by the manufacturer.

$C = 8 (d - 14 \text{ mm})$

d = Protective mechanism's resolution (minimum detectable obstruction size).

The resolution d is stated in the type plate of the TLCT light curtain.

At $d = 14 \text{ mm}$, $C = 0 \text{ mm}$

At $d = 30 \text{ mm}$, $C = 128 \text{ mm}$

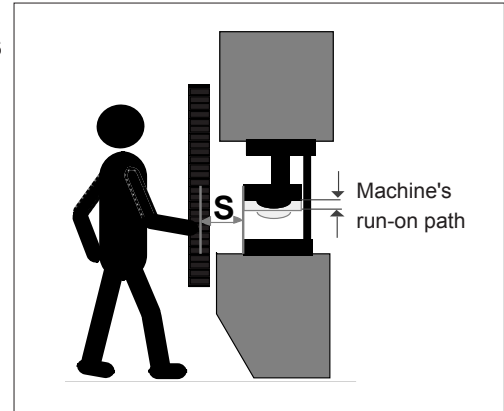

Fig. 12/1 Vertical safeguarding of hazard zones

At $S = 100 \text{ mm}$ to 500 mm :

$$S = (2000 \text{ mm} / \text{s} \cdot T) + C$$

At $S > 500 \text{ mm}$:

$$S = (1600 \text{ mm} / \text{s} \cdot T) + C$$

Sample calculations of safety clearance: Valid to a resolution of 40 mm

Example 1:

Safety light curtain TLCT100/12

- Reaction time 5 ms,
- Resolution $d = 14 \text{ mm}$,
- Machine run-on time $t_2 = 75 \text{ ms}$

$$S = 2000 \text{ mm} / \text{s} \times (0,075 \text{ s} + 0,005 \text{ s})$$

$$\underline{S = 160 \text{ mm}}$$

Example 2:

Safety light curtain TLCT500/20

- Reaction time 6 ms,
- Resolution $d = 30 \text{ mm}$,
- ULSG reaction time = 6 ms
- Machine run-on time $t_2 = 75 \text{ ms}$

$$S = 2000 \text{ mm} / \text{s} \times (0,075 \text{ s} + 0,006 \text{ s} + 0,006 \text{ s}) + 8 \times (30 \text{ mm} - 14 \text{ mm})$$

$$\underline{S = 302 \text{ mm}}$$

Horizontal safeguarding of hazard zones with a light grid (EN 999 / ISO 13855)

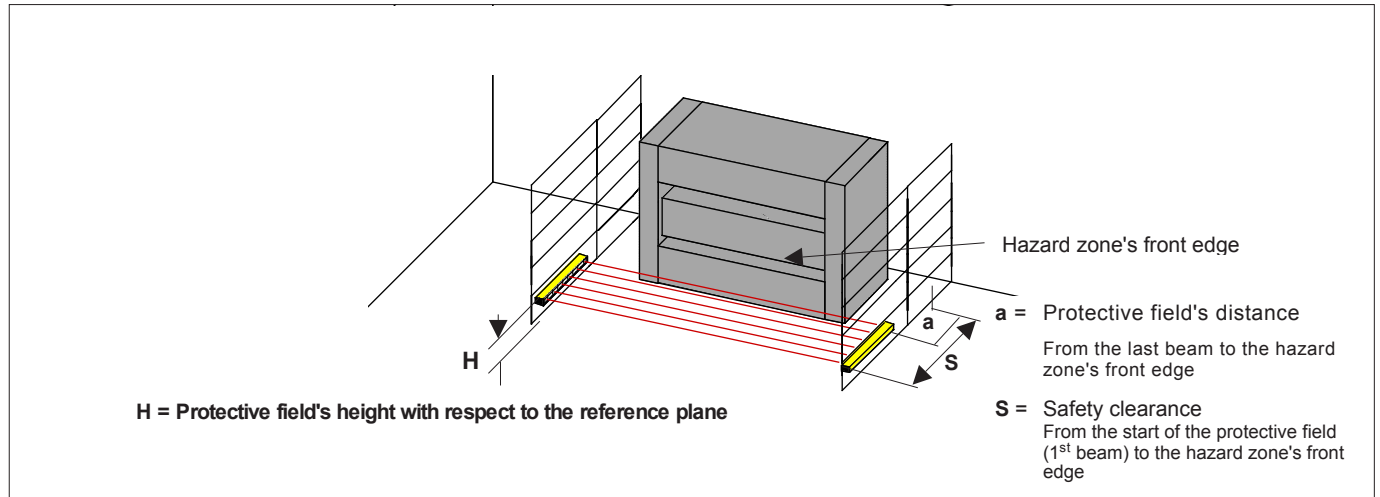

Fig. 13/1: Horizontal safeguarding

Formula for calculating safety clearance during horizontal safeguarding of hazard zones using light curtains:

$$S = (K \times T) + C$$

In this case:

$$K = 1600 \text{ mm/s}$$

$C = 1200\text{mm} - 0,4H$, ut smaller than 850 mm, H being the height of the protective field in mm above the reference plane, e.g. the floor

$T = t_1 + t_2$ (also refer to Page 12)

$t_1 =$ Protective mechanism's reaction time

$t_2 =$ Machine's run-on time

$$S = (1600 \text{ mm} / \text{s} \times T) + (1200 \text{ mm} - 0,4 H)$$

If the protective field is at a height of ≥ 300 mm above the floor, there is a danger of slipping beneath it. This must be considered when assessing risks.

Accordingly, at $H \geq 300$ mm:

$$1200 - 0,4 \times H > 850 \text{ mm}$$

The clearance a to the end of the protective field (between the last beam and the hazard zone's front edge) must not exceed:

$$a = H / 15 + 40 \text{ mm}$$

Example:

Height 200 mm

$$a_{\text{max}} = 200 / 15 + 40 \text{ mm}$$

$$a_{\text{max}} = 53 \text{ mm}$$

Sample calculation of safety clearance during horizontal safeguarding of hazard zones using TLCT light curtains:

Example:

Safety light curtain **TLCT1200/144**

Light curtain's reaction time: **t1: 17 ms**

Machine's run-on time **t2: 50 ms**

H = 200 mm

The safety clearance is:

$$S = (1600 \text{ mm} / \text{s} \times (0,050 \text{ s} + 0,017 \text{ s})) + (1200 \text{ mm} - 0,4 \times 200 \text{ mm})$$

$$S = 1228 \text{ mm}$$

With the TLCT 1200/144, the protective field has a depth of 1200 mm.

The distance a between the last beam and the hazard zone's front edge is therefore $28 \text{ mm} + 5 \text{ mm} = 33 \text{ mm}$ (the last beam must be added).

Distance to reflective surfaces



To prevent reflective objects from hindering a clear view and detection of obstructions, TLCT/ ILCT safety light curtains must be mounted at a minimum clearance a (Figure 14/1) from such reflective objects.

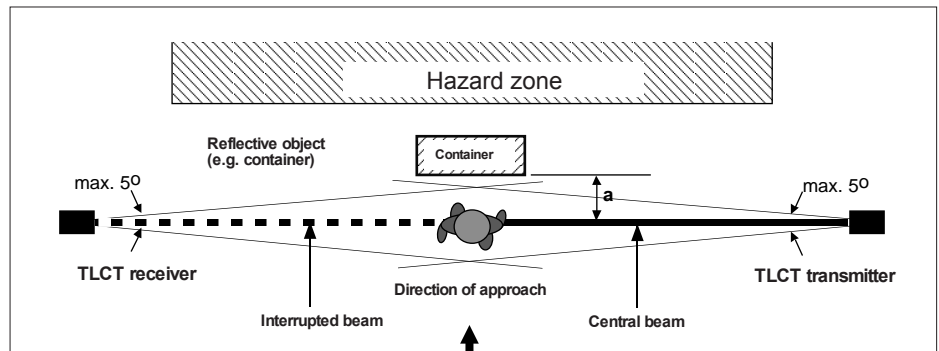

Fig. 14/1: Clearance to reflective surfaces

The minimum clearance a is listed in the adjacent table.

Installation range in m	To 3	4	5	6
Clearance a in mm	130	175	219	262

Table 14/2: Installation range / clearance

Assembly without additional safeguarding

The light transmitter (a) (Figure 15/1) and light receiver (b) together produce a light curtain (c). If a light beam is interrupted, e.g. by a human hand, the control circuit opens, thereby stopping the machine's closure.

In this example, the TLCT/ ILCT safety light curtain cannot be bypassed from the working side, eliminating the need for additional safeguarding at the front.



To prevent the protective field from being infiltrated from the rear, the gap between the TLCT/ ILCT light curtain and the machine must be ≤ 75 mm.

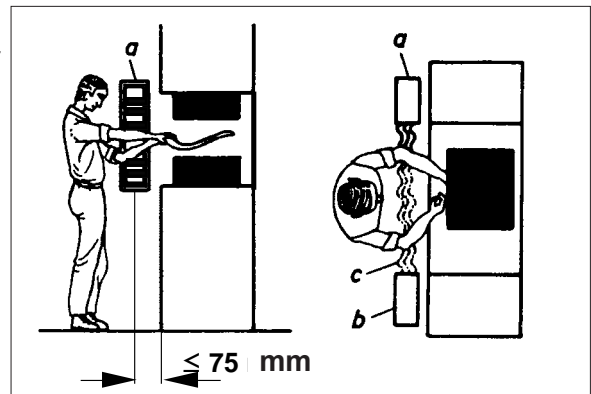

Fig. 15/1: Assembly without additional safeguarding

Protection against infiltration from below and above



In the normal operating procedure (Figure 15/2a), the operator places workpieces in the seated position. To allow for the machine's run-on time, the TLCT/ ILCT safety light curtain (a) is mounted at a distance before the hazard zone (refer to Chapter 2.2).

At the protection height selected here, an exposed gap results above the light curtain.

Figure 15/2b shows how reaching over the light curtain can cause an accident. Figure 15/2c shows how this can be remedied by installing a TLCT/ ILCT safety light curtain providing a higher protective field.

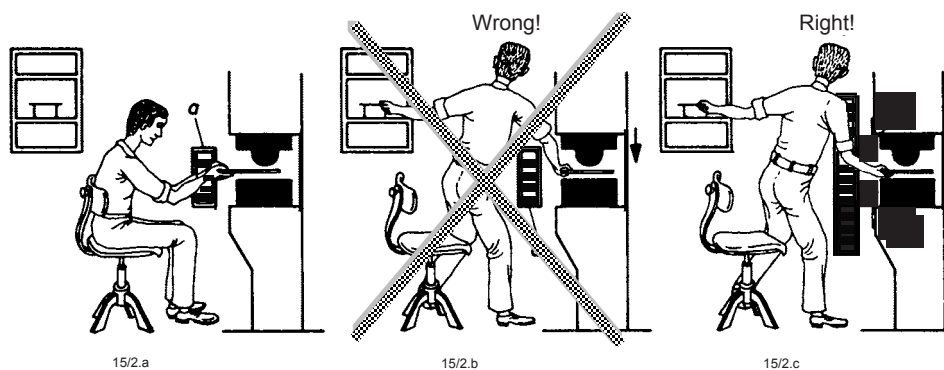

Figures 15/2 a,b,c: Protection against infiltration from below and above

Cascading or additional safeguarding to prevent infiltration from the rear



If the gap between the vertical TLCT/ ILCT safety light curtain and the machine is larger than 75 mm (e.g. to maintain a safety margin to the hazard zone), infiltration from the rear must be prevented by means of an additional TLCT/ ILCT safety light curtain, two cascaded light curtains (Figures 15/3 and 15/4) or a protective bar.

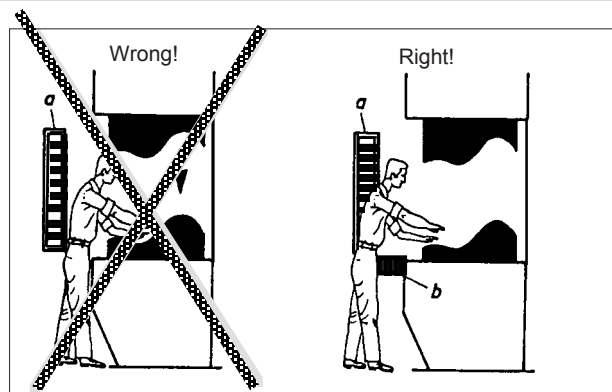

Fig. 15/3: Two cascaded safety light curtains to prevent infiltration from the rear

Arrangement of two neighbouring safety light curtains



To prevent mutual interference between two neighbouring safety light curtains, these must be installed as shown next.

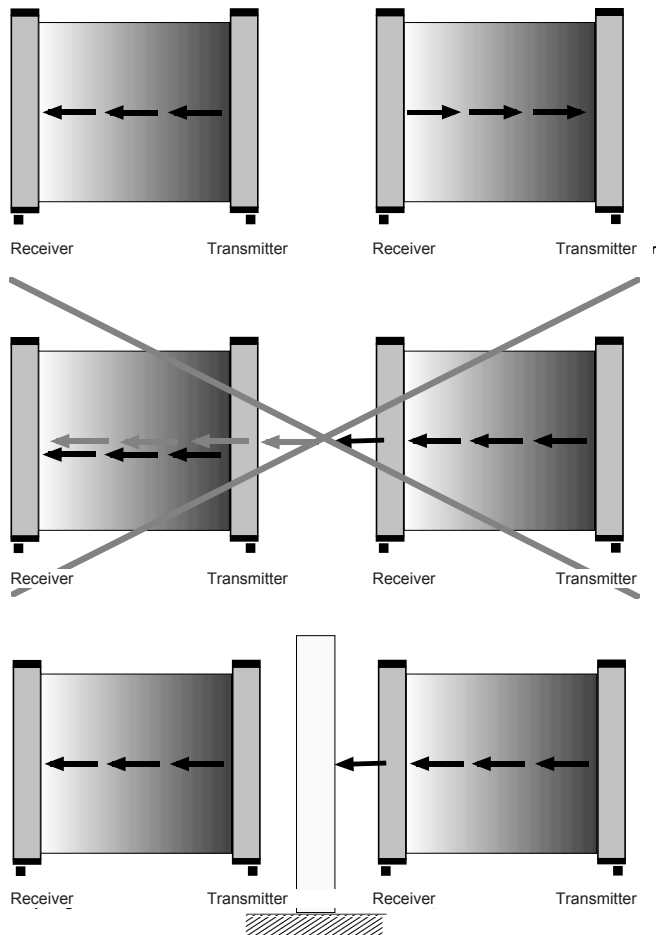

Fig. 16/3: Arrangement of two neighbouring light curtains

Swivel mounting

The TLCT/ILCT can be mounted on the side or the rear with the help of the accompanying swivel fixtures. A long and a short swivel fixture are included.

The short swivel fixture is to be attached by means of the accompanying plastic bolt.

The long swivel fixture is to be attached using the lock nuts of the TLCT/ILCT light curtain's M12 connector.

Depending on the required type of mounting (lateral or rear), the fixture must be installed as explained further below.



Lateral mounting



Rear mounting



Short swivel fixture (with fixing screw) attached via a plastic bolt



Long swivel fixture attached via an M12 connector

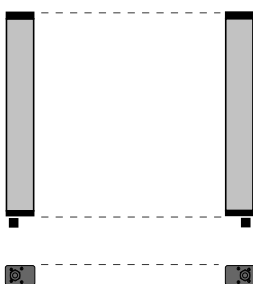

Important:

The light transmitter and receiver must be attached to stable, rigid, plane-parallel structures.

Make sure that the profile is resistant to torsion, otherwise proper optical adjustment will not be possible.

When mounting the transmitter and receiver, ensure that both devices' connectors are located on the same side.

Adjustment:

Perform corrections to the transmitter's and receiver's mutual alignment until the 7-segment display and adjustment-aid LED go off.

LEDs and displays are described on

Page 6

Lateral mounting of TLCTs



Supplied parts: The crossed-out parts are needed only if the swivel range proves insufficient.

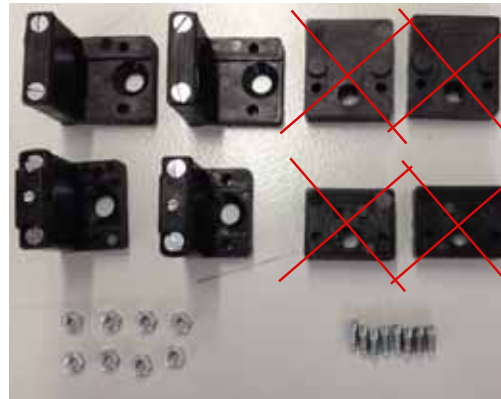

8 nuts (M3) , 8 adjustment screws (M3 x 8)



The long swivel fixture is meant for the side with the M12 connector.

The short swivel fixture is meant for the side with the plastic bolt.
(with fixing screw)

Important:

The light transmitter and receiver must be attached to stable, rigid, plane-parallel structures.

Make sure that the profile is resistant to torsion, otherwise proper optical adjustment will not be possible.

When mounting the transmitter and receiver, ensure that both devices' connectors are located on the same side.

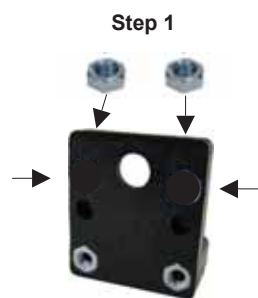

Press 2 M3 nuts into the swivel fixture.



M3 nuts fully pressed in.

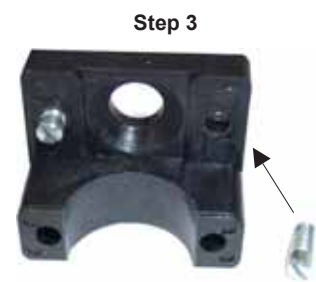

Insert 2 each of the accompanying adjustment screws via the through-bores into the M3 nuts pressed in at the rear.



Attach the short swivel fixture to the plastic bolt.



Fasten the long swivel fixture via the connector's M12 nuts.

Step 6
The light curtain is to be mounted by means of M6 countersunk screws (not included in the scope of delivery).

Refer to Page 10 of Chapter 1.8 (dimensions) for mounting clearances.



Step 7

Now the light curtain can be swivelled by about $\pm 10^\circ$ and aligned optimally by means of the adjustment screws. The light curtain can be adjusted even with the M12 plug in place.

Perform corrections to the transmitter's and receiver's mutual alignment until the 7-segment display and adjustment-aid LED go off.

If the swivel range is insufficient, the auxiliary widening elements can be fitted to permit omni-directional swivelling beyond the edges (refer to rear assembly).

After adjustment, the fixing screw must be tightened to prevent accidental move. Subsequently the fastening screws must be tightened.

Display:

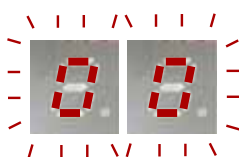

1st light beam is interrupted.

Also refer to Page 6.

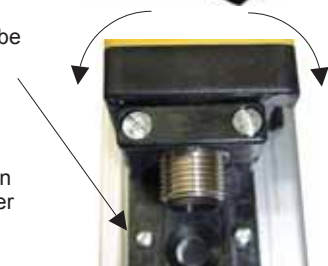

Rear mounting of TLCTs



Supplied parts:

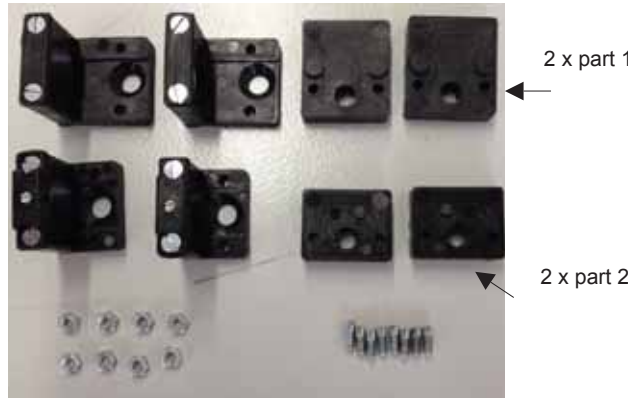

8 nuts (M3) , 8 adjustment screws (M3 x 8)



The long swivel fixture is meant for the side with the M12 connector.

The short swivel fixture is meant for the side with the plastic bolt.
(with fixing screw)

Important:

The light transmitter and receiver must be attached to stable, rigid, plane-parallel structures.

Make sure that the profile is resistant to torsion, otherwise proper optical adjustment will not be possible.

When mounting the transmitter and receiver, ensure that both devices' connectors are located on the same side.

Step 1

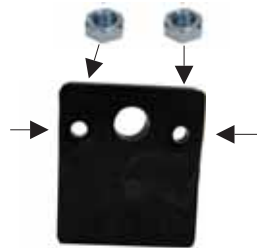

Press 2 M3 nuts each into the top ends of the widening elements

Step 2



M3 nuts fully pressed in.

Step 3



On parts 1 and 2: Insert 2 each of the accompanying adjustment screws via the through-bores into the M3 nuts pressed in at the rear.

Step 4



The adjustment screws can be turned inside the through-bores.

Step 5



Attach the short swivel fixture to the plastic bolt.

Step 6



Fasten the long swivel fixture via the connector's M12 nuts.

The widening element can be fitted to permit swivelling of the TLCT in all directions beyond the edges.

Display:

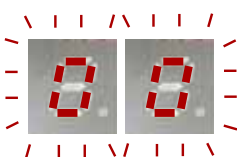

1st light beam is interrupted.

Also refer to Page 6.

Step 7

The light curtain is to be mounted by means of M6 countersunk screws (not included in the scope of delivery).

Refer to Page 10 of Chapter 1.8 (dimensions) for mounting clearances.

Step 8

Now the light curtain can be swivelled in all directions even beyond the edges, and aligned optimally by means of the adjustment screws. The light curtain can be adjusted with the M12 plug in place.

Perform corrections to the transmitter's and receiver's mutual alignment until the 7-segment display and adjustment-aid LED go off.

After adjustment, the fixing screw must be tightened to prevent accidental move. Subsequently the fastening screws must be tightened.

Shackles / optional

Optional shackles are also available for fastening and adjusting light curtains. In conjunction with movable slot blocks, these shackles permit universal fastening.

For swivelling about the longitudinal axis, turn the corresponding adjustment screw on one shackle after loosening the two screws on the other shackle.

For swivelling about the transverse axis, equally turn both adjustment screws on one shackle after loosening the two screws on the other shackle.



Important:

To ensure error-free operation, the light transmitter and receiver must be attached to stable, rigid, plane-parallel structures.

Install the shackles so that the adjustment screws remain fully accessible.

Make sure that the profile is resistant to torsion, otherwise proper optical adjustment will not be possible. Loosen the adjustment screws on one shackle before adjusting the other shackle.



Adjustment screws

Adjustment:

Perform corrections to the transmitter's and receiver's mutual alignment until the 7-segment display and adjustment-aid LED go off.

LEDs and displays are described on [Page 6](#)

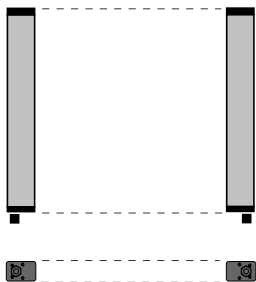

When mounting the transmitter and receiver, ensure that both devices' connectors are located on the same side.

Ensure plane-parallel mounting of the transmitter and receiver.

Mounting with a slot block and threaded bolt / optional



Another means of mounting is to position a block (available from Fieessler Elektronik) in the slot on the rear of the TLCT.

A threaded bolt is then screwed into the block via a through-bore.

Ensure plane-parallel mounting of the transmitter and receiver.

Since fine adjustment is not possible here, the installation site must permit plane-parallel and torsion-free mounting.

Multi-sided safeguarding via deflecting mirrors / optional

Mirrors can be used to deflect a protective field around hazard zones, permitting creation of multi-sided barricades. The law of light reflection, i.e. angle of incidence = angle of reflection, applies here. To achieve a deflection of 90°, the mirror must therefore be positioned at an angle of 45°. The deflecting mirrors have swivel bearings for this purpose.

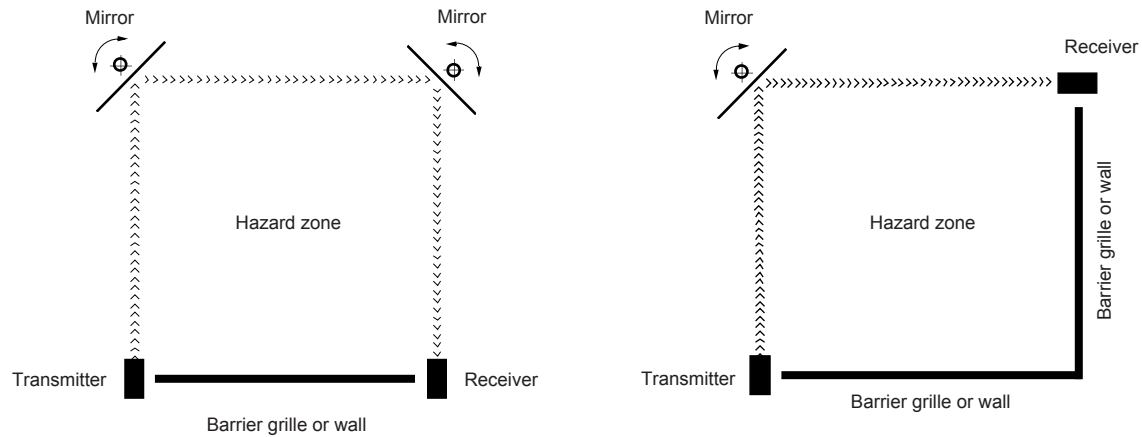

Reflection losses: Each time it is deflected by a mirror, the transmitted signal is attenuated. When using such mirrors, you should therefore account for the signal's maximum range and the number of required deflections. Make sure to mount transmitter, receiver and mirrors perpendicularly and check their alignment with a spirit level.

Connector for the TLCTE receiver

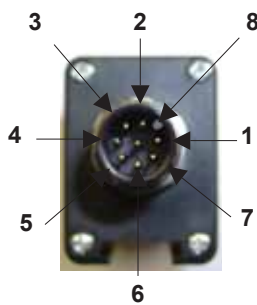

Pin 1 / white:	Start	Enabling of start with restart interlock, max. 24V DC +/- 20%
Pin 2 / brown:	+UB	+24V DC +/-20% SELV, PELV
Pin 3 / green:	-	
Pin 4 / yellow:	EDM	Contactor control, max. 24V DC +/- 20%
Pin 5 / grey:	OSSD1	Safety output 1, max. 500 mA
Pin 6 / pink:	OSSD2	Safety output 2, max. 500 mA
Pin 7 / blue:	-UB	0V
Pin 8 / red/shield:-		

Connection with restart interlock / with contactor control (EDM)

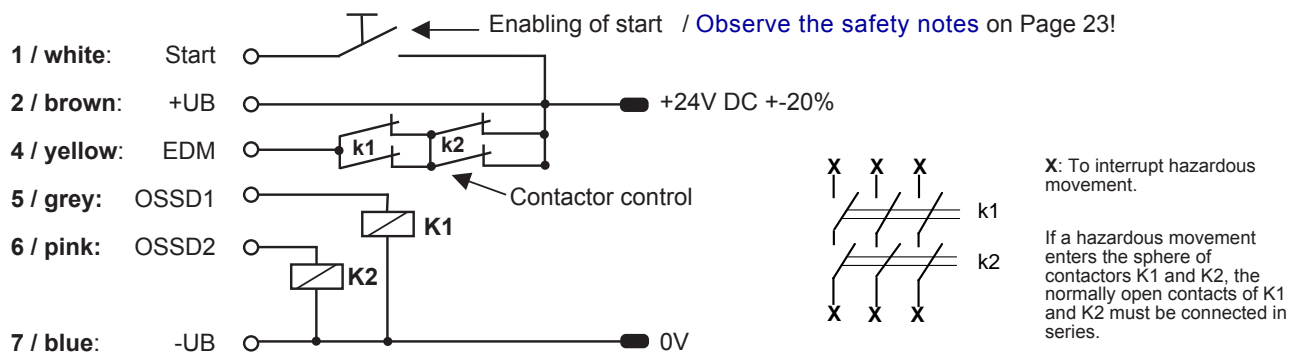

Connection without restart interlock / without contactor control (EDM)

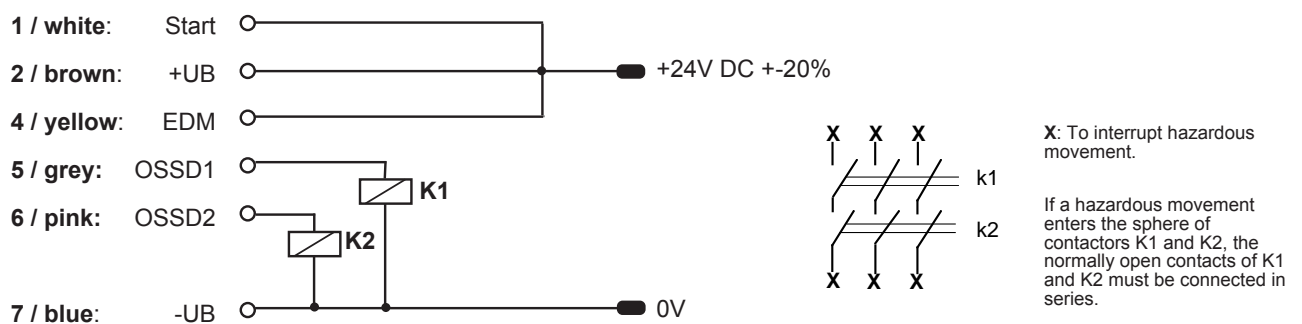

Connector for the TLCTS transmitter

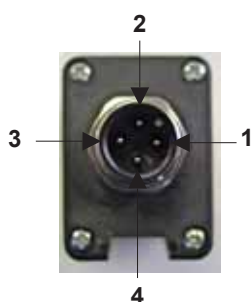

Pin 1 / brown:	+UB	+24V DC +20%-15% SELV, PELV
Pin 2 / white:	\perp	Functional earth
Pin 3 / blue:	-UB	0V
Pin 4 / black:	-	



All safety notes are identified by this symbol and must be observed on all accounts!

Condition for using Type 2 safety light barriers

Type 2 safety device may only be applied, if the machine-specific C standard allows this expressly or the risk assessment pursuant to EN 1050 resp. En 951-1, fig. C1 and E1 prove a little (II) to medium risk degree (III).

User-friendly self-testing: The customary testable Type 2 light curtains required a external cyclic system test. With TLCT light curtains, this is no longer necessary, because a continuous internal self-testing is active.

Safe functionality of the entire system is ensured only under observance of this operating manual and relevant accident prevention regulations.

Forming part of the light curtain's scope of delivery, this operating manual must be kept where the light curtain has been installed.

All instructions in this manual must be observed on all accounts. This operating manual provides important details on proper use of the TLCT safety light curtains.

Observe valid standards and directives when using safety light curtains. Related information can be obtained from local authorities and trade associations. These associations' relevant ordinances and guidelines must also be observed.

Only qualified staff should assemble, commission and maintain the system.

Before commissioning a machine furnished with TLCT safety light curtains, ensure that no-one is present any longer in any of the hazard zones. Affix appropriate warning signs to the machine.

Light curtains do not provide any protection against projectiles arising through operation of the machine.

When using a TLCT with external switchgear or similar downstream-connected control devices, implement appropriate operational / organizational measures to ensure deactivation or testing at least once a day for the purpose of identifying and precluding faults on the switchgear.

Important daily check (at least once every 24 hours):

Using the test rod*, interrupt the light barrier on the transmitting side from the start to the end of the protective field so that the light field is only covered by this part. The green LED (or the yellow LED in the operating mode with restart interlock) must not light up from start to finish.

* The test rod's diameter must correspond to the detection capacity indicated on the receiver's type plate.

Prerequisites for the use of safety light curtains:

- The clearance between the protective field and the hazard zones must be large enough to stop the machine before any of its components can reach a hazard zone following penetration of the protective field.
- Access to the hazardous area must only be possible through the protective field (reaching under, over or around the field must not be possible).
- Passage through the light curtain must only be possible if the restart interlock is activated on interruption of the light curtain.
- A new command to activate the next hazardous machine movement must only be implemented via an **enabling switch**. This **start button** must not be operable from the hazardous area and must be located at a point from which the accessible area can be viewed without obstruction.
- It must be possible for hazardous machine condition to be terminated by the sensor function.
- Unintentional repetition of a hazardous movement must be prevented by appropriate safety facilities.
- The safety category (type 2) of the accident-prevention light curtain should be at least the same as the safety category of the machine control unit.
- **Acceptance test:**
The acceptance tests for the installation should be carried out by competent personnel who are in possession of all information provided by the supplier of the machine and the BWS (contactless protective mechanisms).
- **Annual inspections:**
The operator must ensure that a competent person is assigned the task of inspecting the light curtain and its integration into the machine on a yearly basis. This person may, for example, be employed by the light curtain's manufacturer or the operator.

On request by the customer, Fiessler Elektronik carries out initial acceptance tests and annual inspections. In addition, seminars providing customers with training in annual inspections are held at regular intervals.

Connectable components:

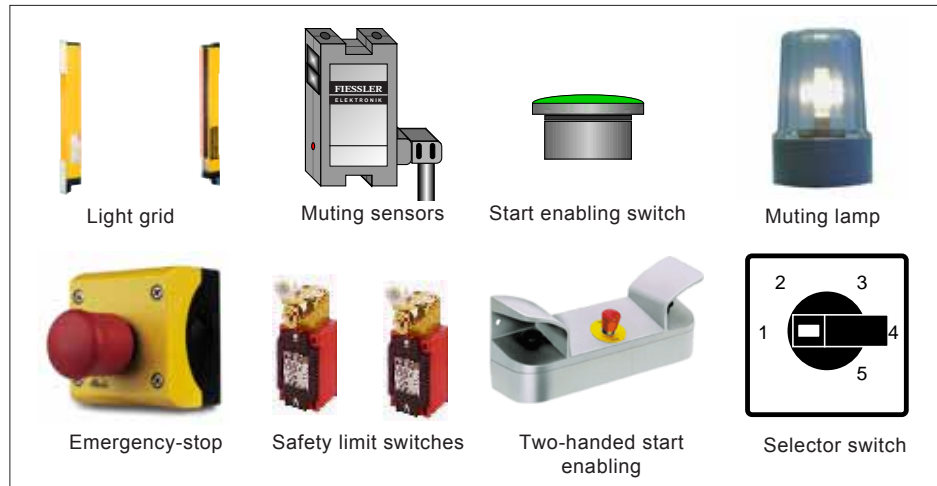
 PLSG3K_RP
 in a switch cabinet housing

Additional functions	PLSG1K	PLSG2K	PLSG3K	BLPG	BPSG	ULSG	ULSG3/6
	Muting controller	Muting controller	Universal controller	BLCT/ILCT-Programming unit	BLCT/ILCT programming and switching device	Switching device	Switching device
Muting Temporary bridging of the light grid	●	●	●	-	-	-	-
Potential-free switching contacts	optional ...1KR	optional ...2KR	optional ...3KR	-	●	●	●
Restart interlock only during hazardous working motion (e.g. insertion operations). Infiltration of the protective field at a standstill or during safe movement is possible without renewed enabling of start.	-	-	●	-	-	-	-
Cyclical control (e.g. during insertion operations) The machine functions in accordance to cyclical infiltration of the protective field 1-cycle, 2-cycle, 3-cycle or 4-cycle mode	-	-	●	-	-	-	-
ILCT light grid blanking functions 11 protective field blanking types	-	-	●	●	●	-	-
Selector switch operation Up to 5 operating modes and/or blanking types can be saved and invoked again via a selector switch.	-	optional ...2KP	optional ...3KP	●	●	-	-
Connections for 2 – 6 light curtains	-	-	-	-	-	ULSGDUO: 2	●
Emergency-stop circuit monitor Protective doors, emergency-stop switches	-	-	●	-	-	-	-
Two-handed start Start enabling via a two-handed switch	-	-	●	-	-	-	-
2-stage output deactivation Deactivation of control drives (e.g. robots)	-	●	●	-	-	-	-
LCD display - 2 x 8 characters Status and error messages	-	●	●	-	-	-	-
Override After irregular stop	●	●	●	-	-	-	-
Connection voltage	24 VDC	24 VDC	24 VDC	24 VDC	24 VDC, 115 VAC, 230 VAC	24 VDC, 115 VAC, 230 VAC	24 VDC

Additional safety notes for ILCT



All safety notes in Chapter 7 must be observed on all accounts!

Incorrect use of the blanking function or improper integration of it into the machine's processes can pose serious hazards. For this reason, it is extremely important to fully understand and meet the requirements for use of the blanking function as described in this operating manual.

Usually, additional mechanical protective systems are needed to prevent access to hazardous zones resulting from a bypass of blanked machine components.

If such additional mechanical protective systems are removed, measures must be implemented to deactivate the machine.

- a. Viability of the application:** The viability of each application in the various possible operating modes must be examined. In conjunction with the BPSG switching device, the ILCT light curtain offers a number of functions. The viability of each function must be assessed individually for each application. Here, it is important to ascertain whether and how the blanked sectors can be safeguarded by means of additional mechanical systems, and to examine the installation of the machine / equipment from this perspective. Individual configurations must undergo safety checks by an expert.
- b. Mechanical protection against infiltration:** Auxiliary safeguards against infiltration installed besides the blanked machine components must either be incapable of removal with the aid of simple tools, or monitored by means of position switches and integrated into the safety routine.
- c. Reaction time:** Reaction times are somewhat longer compared with TLCT light curtains. Refer to Page 11 of Chapter 2.
- d. Programming the blanking function:** Blanking modes can be programmed either directly at the factory, or by the customer with the help of devices of the PLSGK, BLPG and BPSG series. Refer to Page 28. Programming must only be performed by authorized personnel. This must be ensured through use of a key switch. The switch must be stored at a secure location outside the installation to prevent programming by unauthorized persons. Following completion of teach-in, the machine must not be permitted to restart automatically. If start and restart interlock have not been implemented by the light curtain, they must be activated from a higher level control system.
- e. Key-switch installation point:** The key switch must be installed at a point on the machine providing a clear view of the protective field when the switch is operated.
- f. Check the protective field after re-programming or replacing the receiver:** Pass the test rod through the protective field once directly before the transmitter, once directly before the receiver, and once halfway between the two (see Figure 25.4). The green and yellow LEDs must remain off in this process. This is done to detect any deflection by reflective components initialized inside the protective field.
- g. Indication of current resolution and protective field:** The current resolution must be indicated by auxiliary signs on the device. When the light curtain is free, the LED for restart interlock (yellow) and the alignment LED (orange) must additionally flash at about 1 Hz to indicate reduced resolution mode or floating blanking mode. Reduced resolution influences the safety clearance and must be taken into account.
- h. Blanking must extend across the protective field's entire width to prevent infiltration from the side.**

See Figures 25.1, 25.2 and 25.3

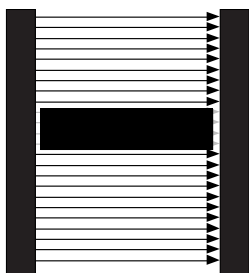

Fig. 25.1: Fixed or floating blanking with complete coverage of the light curtain's blanked section..

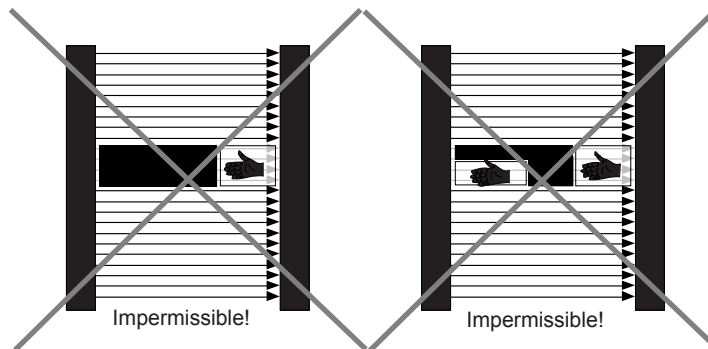

Fig. 25.2: Fixed or floating blanking with partial coverage of the light curtain's blanked section. Additional coverage is necessary.

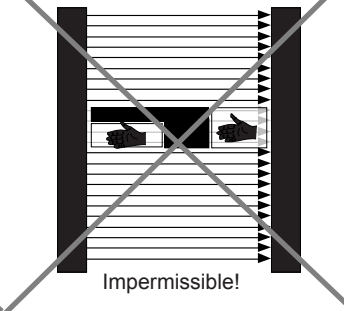

Fig. 25.3: Fixed or floating blanking with partial coverage of the light curtain's blanked section. Additional coverage is necessary.

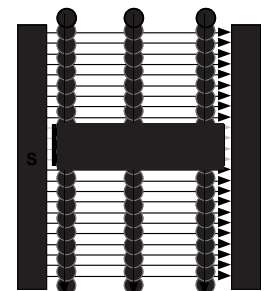
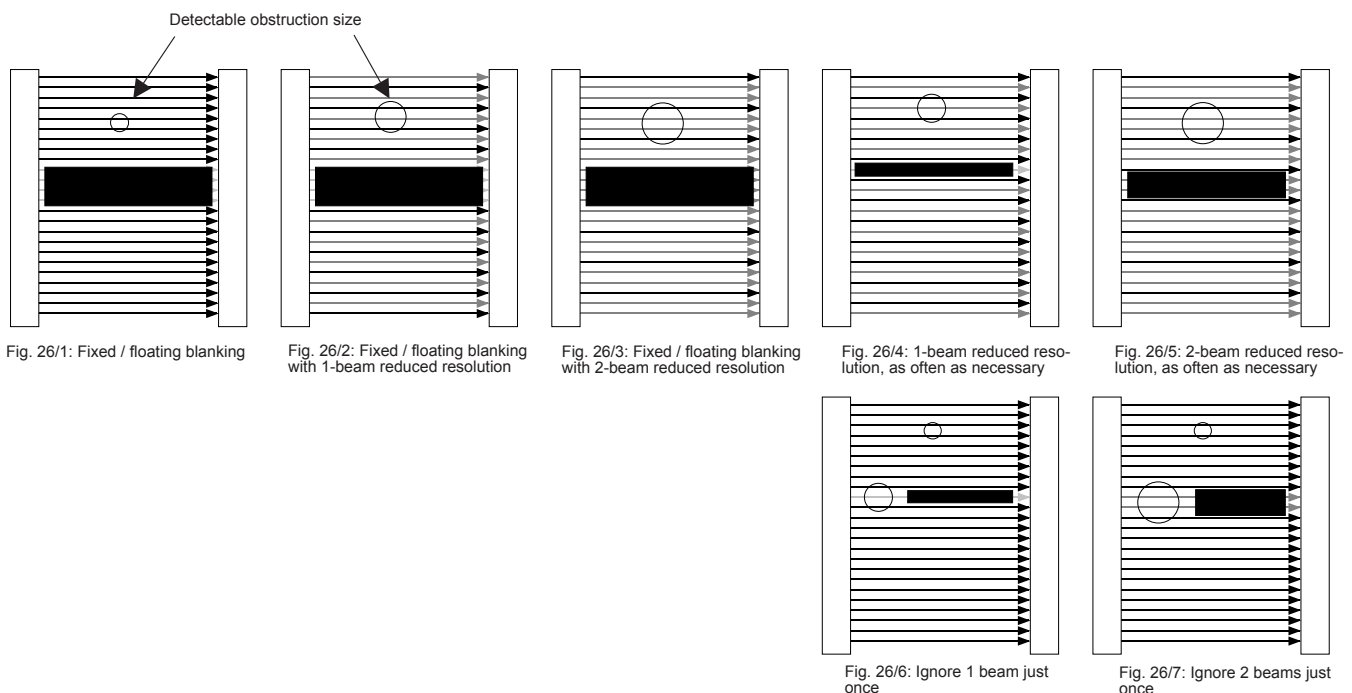

Fig. 25.4: Traversing of the protective field with an appropriate test rod.

Blanking modes and typical applications

Blanking is used to disable parts of a protective field, e.g. to permit workpieces and/or machine components to penetrate the protective field without impairing the machine's functionality.

Blanking mode	Typical application
1. Blanking off	Full protection throughout the protective field. Resolution and deployment as with TLCT.
2. Fixed blanking Fig. 26/1	Blanking of up to 5 objects located at fixed coordinates inside the protective field (e.g. bearing table or material feed unit).
3. Fixed blanking with 1-beam reduced resolution Fig. 26/2	Combination of 2 nd and 8 th blanking modes for up to 5 objects located at fixed coordinates inside the protective field, and thin movable objects (e.g. hoses and cables) which infiltrate the protective field occasionally or regularly, interrupting no more than 1 beam in the process.
4. Fixed blanking with 2-beam reduced resolution Fig. 26/3	Combination of 2 nd and 9 th blanking modes for up to 5 objects located at fixed coordinates inside the protective field, and thin, movable objects (e.g. hoses and cables) which infiltrate the protective field occasionally or regularly, interrupting no more than 2 beams in the process.
5. Floating blanking) Fig. 26/1	Blanking of an object which moves inside the protective field (e.g. height-adjustable table).
6. Floating blanking with 1-beam reduced resolution Fig. 26/2	Combination of 5 th and 8 th blanking modes for an object which moves inside the protective field, and thin, movable objects (e.g. hoses and cables) which infiltrate the protective field occasionally or regularly, interrupting no more than 1 beam in the process.
7. Floating blanking with 2-beam reduced resolution Fig. 26/3	Combination of 5 th and 9 th blanking modes for an object which moves inside the protective field, and thin, movable objects (e.g. hoses and cables) which infiltrate the protective field occasionally or regularly, interrupting no more than 2 beams in the process.
8. 1-beam reduced resolution Fig. 26/4	Thin, movable objects (e.g. hoses and cables) which infiltrate the protective occasionally or regularly, interrupting no more than 1 beam in the process.
9. 2-beam reduced resolution Fig. 26/5	Thin, movable objects (e.g. hoses and cables) which infiltrate the protective occasionally or regularly, interrupting no more than 2 beams in the process.
10. Ignore 1 beam just once Fig. 26/6	One flat object to be machined may infiltrate the protective field at any required point (except synchronous beam), e.g. when blanking sheet metal on a press brake).
11. Ignore 2 beams just once Fig. 26/7	One flat object to be machined may infiltrate the protective field at any required point (except synchronous beam), e.g. when blanking thick sheet metal on stamping & bending presses).



Important notes, restrictions and resolutions for each blanking mode

Important note on the synchronous beam: The first beam (as seen from the plug connector) must not be darkened as it serves to synchronize the transmitter and receiver. If the first beam is covered during the process of teach-in, this process is interrupted for the light curtain's blanking sectors until the beam has been freed again.

If the synchronous beam is covered during regular operation, the ILCT light curtain always deactivates the outputs..

Blanking must extend across the protective field's entire width to prevent infiltration from the side.

If an object is absent or has changed in diameter while blanked, the outputs are deactivated.

Blanking mode	Important notes and restrictions	Resolution with a lens grid of 8.33 mm	LED display See Page 29
1. No blanking	Here too, the ILCT's reaction time is somewhat longer than that of the TLCT (see the tables on Page 11).	Full resolution - 14 mm	No flashing
2. Fixed blanking Fig. 27/1	Up to 5 fixed regions can be blanked. The blanked regions may drift up or down by ± 1 beam as a result of vibrations during operation. However, the number of beams taught-in for each blanked region must not increase during operation; it may only decrease by 1 beam. To prevent problems caused by vibrations during operation, the regions should be taught-in so as to encompass the greatest number of beams. If only 1 beam is blanked, however, it must not be released. During teach-in, at least 3 beams must remain free between the individual regions.	Outside the blanked regions: 14 mm	No flashing
3. Fixed blanking with 1-beam reduced resolution Fig. 27/3	Like item 2, but: During teach-in, at least 5 beams must remain free between the blanked regions. One additional beam at a time (except for the synchronizing beam) may be interrupted at any number of points.	Reduced resolution outside the blanked regions: 22 mm	Green/red LEDs flash at about 1 Hz
4. Fixed blanking with 2-beam reduced resolution Fig. 27/3	Like item 2, but: During teach-in, at least 7 beams must remain free between the blanked regions. One or a maximum of two neighbouring beams (except for the synchronous beam) may be interrupted at any number of points in each case.	Reduced resolution outside the blanked regions: 30 mm	Green/red LEDs flash at about 1 Hz
5. Floating blanking Fig. 27/1	One blanked region (at least 2 neighbouring beams) may drift within the protective field during operation. This region must not drift during teach-in. The number of beams taught-in for the blanked region must not increase as a result of vibrations during operation; it may only decrease by 1 beam.	Outside the blanked regions 14 mm	Green/red LEDs flash at about 1 Hz
6. Floating blanking with 1- beam reduced resolution Fig. 27/2	Like item 5, but: The blanked region must interrupt at least 3 neighbouring beams. One additional beam (except for the synchronous beam) may be interrupted at any number of points in each case.	Reduced resolution outside the blanked regions: 22 mm	Green/red LEDs flash at about 1 Hz
7. Floating blanking with 2- beam reduced resolution Fig. 27/3	Like item 5, but: The blanked region must interrupt at least 4 neighbouring beams. One or a maximum of two neighbouring beams at a time (except for the synchronizing beam) may be interrupted at any number of points.	Reduced resolution outside the blanked region: 30 mm	Green/red LEDs flash at about 1 Hz
8. 1-beam reduced resolution Fig. 27/4	One additional beam at a time (except for the synchronizing beam) may be interrupted at any number of points. If several objects are involved, at least 1 beam must remain free in between	Reduced resolution: 22 mm	Green/red LEDs flash at about 1 Hz
9. 2-beam reduced resolution Fig. 27/5	One or a maximum of two neighbouring beams at a time (except for the synchronizing beam) may be interrupted at any number of points. If several objects are involved, at least 1 beam must remain free in between.	Reduced resolution: 30 mm	Green/red LEDs flash at about 1 Hz
10. Ignore 1 beam just once Fig 27/6	One beam (except for the synchronous beam) may be interrupted at any point inside the protective field.	Without objects: 22 mm With object(s): Remaining protective field – 14 mm	Green/red LEDs flash at about 1 Hz
11. Ignore 2 beams just once Fig. 27/7	Two beams (except for the synchronizing beam) may be interrupted at any point inside the protective field.	Without objects: 30 mm With object(s): Remaining protective field – 14 mm	Green/red LEDs flash at about 1 Hz

Table 27/1

Programming units for teaching-in blanking functions

Detailed notes are provided in the operating manual for each programming unit.

Programs remain permanently stored in the ILCT light curtain, also in the de-energized state.

PLSG3 K: Universal control and programming unit for ILCT blanking functions

Teach-in procedure:

1. Set the blanking function means of the four HEX switches provided for this purpose.
2. The objects to be blanked must be located inside the protective field.
3. Turn on the operating voltage.
The connected ILCT light curtain indicates the set blanking function, learns it as well as the blanking position, and then indicates a clear protective field.
4. Reset the HEX switches to the regular operating mode; turn the operating voltage off and on again.



BLPG: Programming unit for ILCT blanking functions

Teach-in procedure:

1. Set the required blanking function by means of the DIP switches provided for this purpose.
2. The objects to be blanked must be located inside the protective field.
3. Move the key switch to the programming setting. Wait until the green LED on the switching device indicates readiness for programming.
4. Remove the key switch. The connected ILCT light curtain indicates the set blanking function, learns it as well as the blanking position, and then indicates a clear protective field.

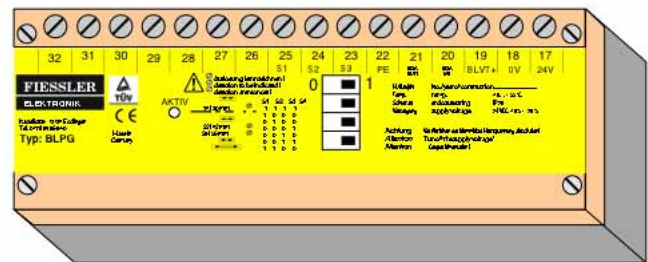

BPSG: Switching device and programming unit for ILCT blanking functions

Like BLPG, but also with a voltage supply and positively controlled relay with potential-free outputs.

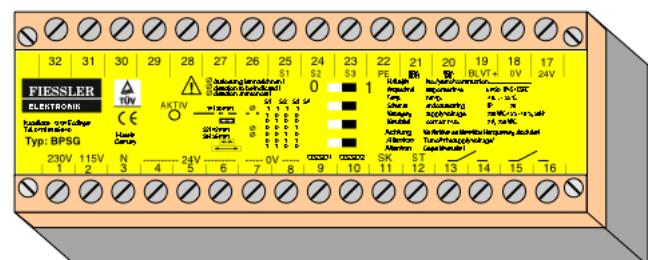

Saving and invocation of up to 5 blanking modes using a selector switch

In conjunction with a programming unit and an external selector switch, up to 5 blanking functions can be saved and invoked again for the ILCT.

A detailed description of this function is provided in the programming unit's operating manual.

Display during programming

During programming, the selected blanking mode is indicated on the display.

Blanking mode	Display
1. Blanking off	
2. Fixed blanking Fig. 29/1	
3. Fixed blanking with 1-beam reduced resolution Fig. 29/2	
4. Fixed blanking with 2-beam reduced resolution Fig. 29/3	
5. Floating blanking Fig. 29/1	
6. Floating blanking with 1-beam reduced resolution Fig. 29/2	
7. Floating blanking with 2-beam reduced resolution Fig. 29/3	
8. 1-beam reduced resolution Fig. 29/4	
9. 2-beam reduced resolution Fig. 29/5	
10. Ignore 1 beam just once Fig. 29/6	
11. Ignore 2 beams just once Fig. 29/7	

Selector switch operation	Display
Selector switch 1	
Selector switch 2	
Selector switch 3	
Selector switch 4	
Selector switch 5	

Display during regular operation



Not flashing:
Blanking off

LEDs during regular operation



The red and yellow LEDs flash about once a second in blanking modes 3 – 11 to indicate reduced resolution or floating blanking.

Additional safety notes for cascaded light grids



All safety notes in Chapter 7 must be observed on all accounts.

Combination of type 4 and type 2 light grids: Whether or not a combination of type 4 and type 2 systems is permissible depends on the hazard analysis. This type of combination does not change a type 2 light grid into a type 4 light grid. When employing this combination, ensure that the main sensor is a type 4 light grid, otherwise the entire system will be converted to type 2.

Light curtain arrangement: When arranging the light curtains, ensure that no optical interference can arise between them. Refer to Chapter 2.3 on installation conditions on Page 16.

Reaction times / safety clearances: The reaction time on interruption of a cascaded light grid increases by 3 ms per series connected light grid. This must be taken into account when calculating safety clearances.

Protective fields must always be assembled using components belonging together (e.g. main sensor as receiver and main sensor as transmitter).

Applications for cascaded light grids

Up to 3 light grids can be cascaded (connected in series). Cascading light grids notably reduces their wiring complexity. Only the main sensor as receiver is connected to the machine control unit and capable of deactivating hazardous movement. The main sensor as transmitter is connected exclusively to the voltage supply.

The main sensor and central light grid must each be cascadable. Every light grid of this kind requires another, downstream-connected light grid and is therefore not available as an individual system. The last series-connected sensor in a cascaded light grid is always a standard system also deployable individually.

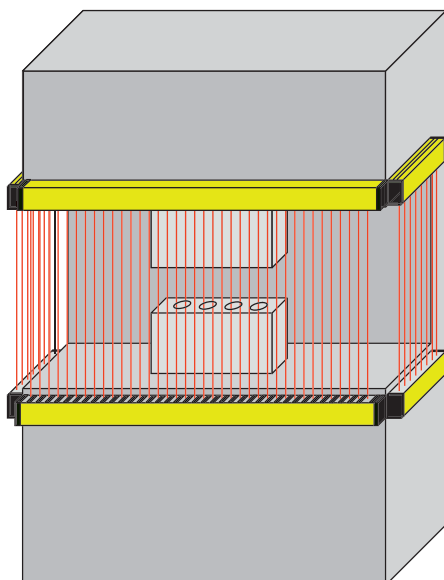

Safeguarding of a C-press on 3 sides without any obstruction by vertical deflecting mirrors.

As opposed to solutions employing vertical deflecting mirrors, cascaded arrangements do not pose any obstructions during a feed of large parts.

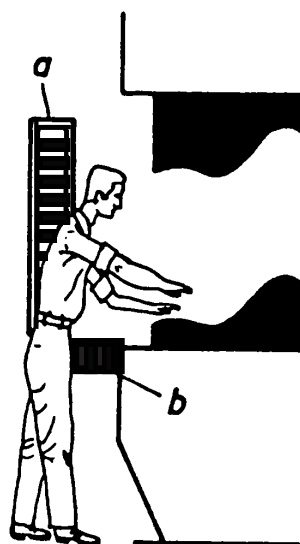

Protection against rear access

For instance:

a = TLCT-K with 14-mm resolution
 b = TLCT with 30-mm resolution

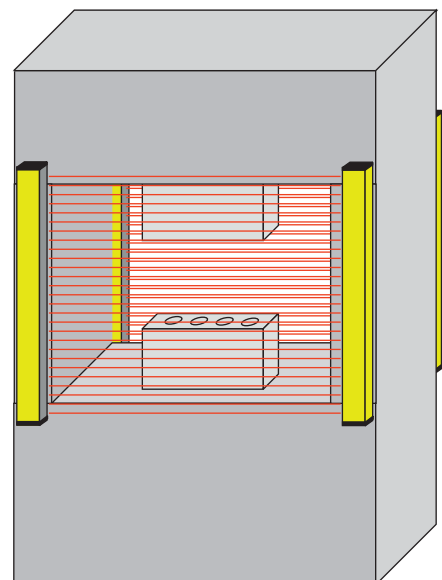

Front and rear safeguarding on a press

Reaction times of cascaded light grids

Cascaded light grids detect an interruption of a downstream-connected sensor within 3 ms.
 The reaction time on interruption of a light grid is equal to its intrinsic reaction time plus 3 ms per preceding light grid.

Main sensor: Intrinsic reaction time (as indicated on the type plate)
Downstream sensor 1: Intrinsic reaction time + 3 ms
Downstream sensor 2: Intrinsic reaction time + 6 ms (2 x 3 ms)

The intrinsic reaction time is stated on the light grid's type plate.
 The table on Page 11 lists intrinsic reaction times of all standard light grids.

Sample calculation	Light grid's intrinsic reaction time (see tables on Page 11)	Calculated reaction time
Reaction time:		
Main sensor: TLCTK 600/72	10 ms	10 ms
Downstream sensor 1: TLCTK 800/96	12 ms	12 ms + 3 ms = 15 ms
Downstream sensor 2: TLCT 200/8	5 ms	5 ms + 6 ms = 11 ms

Safety clearances for cascaded light grids

When calculating safety clearances (refer to Chapter 2.2), note that the reaction time on interruption of a cascaded light grid increases by 3 ms per preceding light grid.

Sample calculation	Resolution (see tables on Page 11)	Light grid's intrinsic reaction time (see tables on Page 11)	Calculated reaction time	Safety clearance, e.g. $S = (K \times T) + C$ ($t_2 = 75 \text{ ms}$)
Safety clearance:				
Main sensor: TLCTK 600/72	14 mm (C= 0 mm)	10 ms	10 ms	S = 170 mm
Downstream sensor 1 TLCTK 800/96	14 mm (C= 0 mm)	12 ms	12 ms + 3 ms = 15 ms	S = 180 mm
Downstream sensor 2 TLCT 200/8	30 mm (C= 128 mm)	5 ms	5 ms + 6 ms = 11 ms	S = 172 mm + 128 mm S = 300 mm

Table for determining the reaction times of cascaded light grids

	Resolution is indicated on the type plate	Light grid's intrinsic reaction time (see type plate)	Calculated reaction time	Application-specific safety clearance (formulae are provided in the Chapter 2.2)
Main sensor: ...LCTK/.....				S =mm
Downstream sensor 1 ...LCTK/.....		 +3 ms =	S =mm
Downstream sensor 2 ...LCT/.....		 +6 ms =	S =mm

Connecting cascaded light grids

The main sensor unit is connected as described in Chapter 3 on [electrical connections](#).



When 3 light grids are cascaded, the connection between the first and second downstream sensors is identical to that between the main sensor and first downstream sensor.

But note that one receiver is always connected to one transmitter and vice versa.

Commissioning and optical alignment of cascaded light grids

Alignment between the transmitter and receiver must always start with the **last** light grid, any light grid being enabled only after the one succeeding it has been enabled.

If the protective field of a downstream sensor in a cascaded light grid is interrupted, the corresponding yellow LED flashes at one-second intervals. If the downstream sensor's protective field is intact, the yellow LED remains solidly lit and the transmitter is ready for operation.

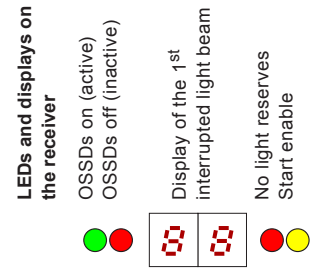

Alignment sequence:
Step 1:

Align downstream sensor 2 first

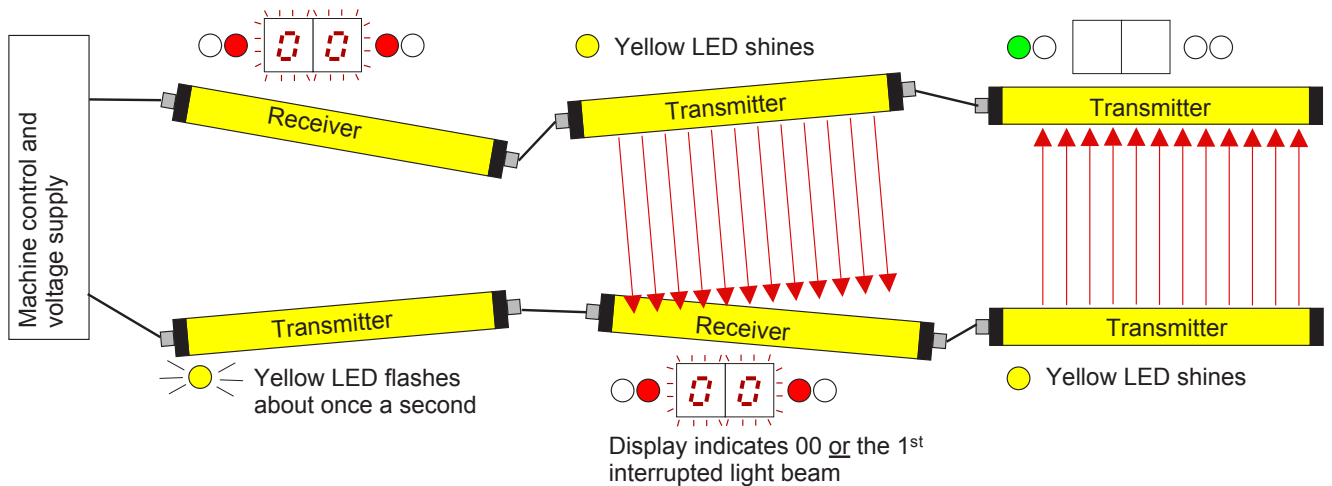

Step 2:

Align downstream sensor 2

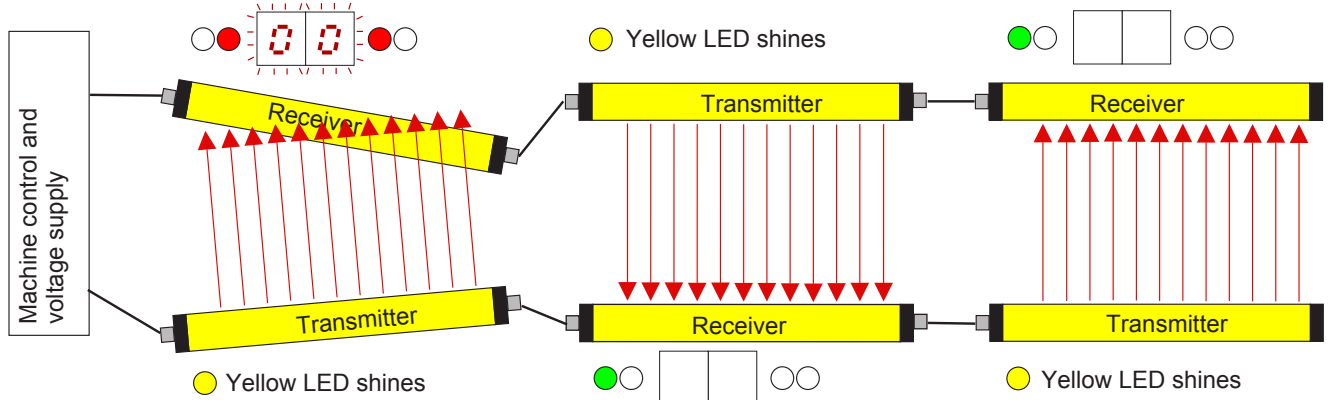

Step 3:

Align the main sensor last

Green or yellow LED (depending on the operating mode) on the main sensor receiver shines when alignment is correct

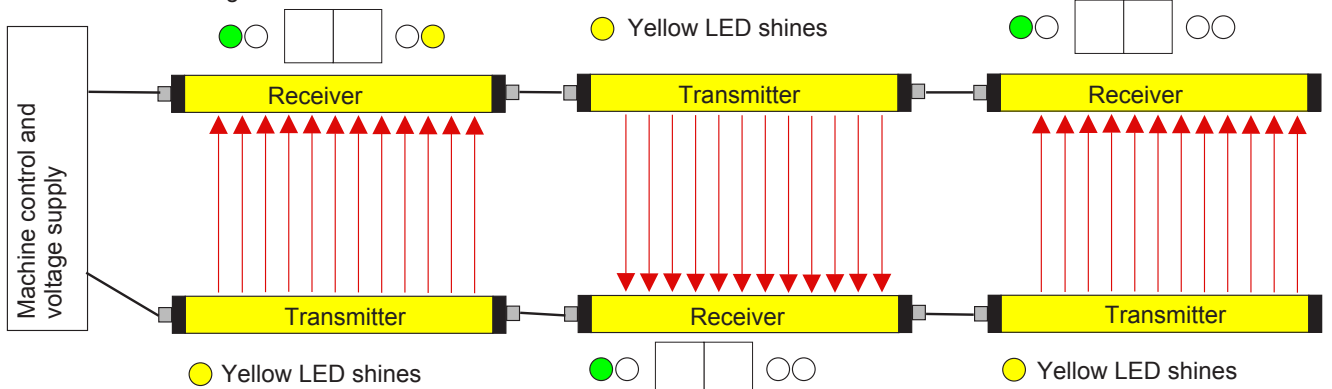

Start interlock

After commissioning or an interruption in the mains power supply, enabling is prevented by a start interlock. The start button must be actuated in order to enable the switching outputs.

Response time

The time which elapses between penetration of the protective field and deactivation.

Blanking

Blanking is used to disable parts of a protective field, e.g. to permit workpieces and/or machine components to penetrate the protective field without impairing the machine's functionality.

Contactless protective mechanisms (BWS)

TLCT safety light curtains are contactless protective mechanisms (BWS). These mechanisms interrupt or prevent hazardous movement on an infiltration of the protective field generated by the transmitter and receiver.

Single/dual-cycle operating mode

Following single/double infiltration, the machine automatically executes an operation and then waits for up to 30 seconds for single/double infiltration.

If the time exceeds 30 seconds, the restart interlock becomes active.

EDM - External Device Monitoring Refer to valve and contactor control.

Installation range (Fig. 35/1)

Minimum and maximum permissible distances between the transmitter and receiver. The installation range is indicated on the TLCT receiver.

Obstruction size (Fig. 35/1)

The obstruction size indicates the minimum obstruction diameter needed for the safety light curtain to reliably interrupt hazardous movement.

Obstruction sizes and corresponding beam ranges for TLCT safety light curtains are listed below.

Max. installation range	5 m	5 m
Min. obstruction size	14 mm	30 mm

Table 35/1a: Installation range, obstruction size, protective field height

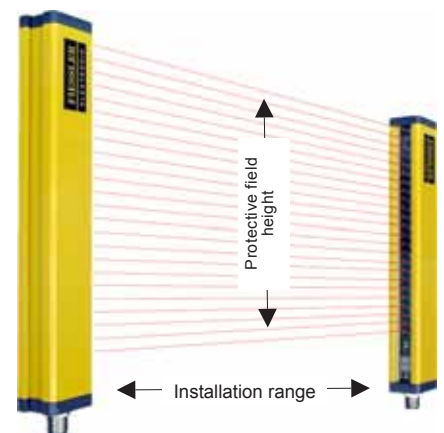

Fig. 35/1: Installation range, obstruction size, protective field height

Muting

Brief and secure bypass of TLCT safety light curtains during material conveyance, e.g. entry into and exit out of a production cell or high-rack warehouse. Reliable distinctions are made here between movements by humans and material.

Run-on distance (Fig. 35/2)

The distance covered by hazardous movement following deactivation (e.g. travel of a ram or a point on a roller's surface).

Run-on time

The time taken to come to a complete stop following deactivation.

Protective field height (Fig. 35/1)

The height of the protective field generated by the transmitter and receiver.

Protective mode

The switching outputs are disabled on interruption of the protective field, and enabled automatically once the field has been cleared again.

Self-monitoring

The automatic response of a contactless protective mechanism to an internal error.

Safety clearance (Fig. 35/2):

The minimum distance needed between a safety light curtain and the nearest hazard zone in order to prevent injury. Safety clearances are calculated with the help of the formulae prescribed by standard EN 999 / ISO 13855, machine-specific C-norms and valid ZH directives.

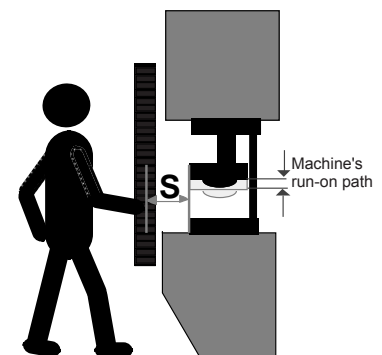

Fig. 35/2: Safety clearance and run-on distance

Safety category 2

The TLCT / ILCT safety light barriers belong to safety category 2 as per EN 945-1 and IEC 61496 / EN 61496. Type 2 safety device may only be applied, if the machine-specific C standard allows this expressly or the risk assessment pursuant to EN 1050 resp. EN 951-1, fig. C1 and E1 prove a little (II) to medium risk degree (III).

User-friendly self-testing: The customary testable Type 2 light curtains required an external cyclic system test.

With TLCT/ ILCT light curtains, this is no longer necessary, because a continuous internal self-testing is active.

Safety category 4

ULCT / BLCT safety light barriers belong to safety category 4 according to EN 954-1 and IEC 61496 / EN 61496.

Devices in safety category 4 are self-monitoring, contactless protective mechanisms representing the highest safety class for devices of this kind.

Beam spacing

The spacing between the individual lens centres of TLCT light curtains.

Valve / contactor control (EDM - external device monitoring)

Before the switching outputs are enabled, the contactor control system always checks whether the connected switching elements (relays, contactors and valves) are released. Only then can the switching outputs be enabled again. This prevents a failure of the switching elements (relays, contactors and valves) used to control hazardous movement.

Restart interlock

This function prevents automatic enabling of the switching outputs following interruption and subsequent clearing of the protective field (e.g. caused by passage through the field).

Type	Order code					
Complete system	Protective field height (mm)	Length L (mm)	Beam count	Complete system	Transmitter	Receiver
TLCT 100/12	100	161	12	TC100/12	TSC100/12	TEC100/12
TLCT 200/24	200	261	24	TC200/24	TSC200/24	TEC200/24
TLCT 300/36	300	361	36	TC300/36	TSC300/36	TEC300/36
TLCT 400/48	400	461	48	TC400/48	TSC400/48	TEC400/48
TLCT 500/60	500	561	60	TC500/60	TSC500/60	TEC500/60
TLCT 600/72	600	661	72	TC600/72	TSC600/72	TEC600/72
TLCT 700/84	700	761	84	TC700/84	TSC700/84	TEC700/84
TLCT 800/96	800	861	96	TC800/96	TSC800/96	TEC800/96
TLCT 900/108	900	961	108	TC900/108	TSC900/108	TEC900/108
TLCT 1000/120	1000	1061	120	TC1000/120	TSC1000/120	TEC1000/120
TLCT 1100/132	1100	1161	132	TC1100/132	TSC1100/132	TEC1100/132
TLCT 1200/144	1200	1261	144	TC1200/144	TSC1200/144	TEC1200/144
TLCT 1300/156	1300	1361	156	TC1300/156	TSC1300/156	TEC1300/156
TLCT 1400/168	1400	1461	168	TC1400/168	TSC1400/168	TEC1400/168
TLCT 1500/180	1500	1561	180	TC1500/180	TSC1500/180	TEC1500/180

**14 mm resolution -
finger protection**

Cascadable light grids are identified with the abbreviation K in the type and order codes.

For instance, codes for type TLCT-K100/12:

Transmitter: TSC-K100/12
Receiver: TEC-K100/12

Type	Order code					
Complete system	Protective field height (mm)	Length L (mm)	Beam count	Complete system	Transmitter	Receiver
TLCT 100/4	100	161	4	TC100/4	TSC100/4	TEC100/4
TLCT 200/8	200	261	8	TC200/8	TSC200/8	TEC200/8
TLCT 300/12	300	361	12	TC300/12	TSC300/12	TEC300/12
TLCT 400/16	400	461	16	TC400/16	TSC400/16	TEC400/16
TLCT 500/20	500	561	20	TC500/20	TSC500/20	TEC500/20
TLCT 600/24	600	661	24	TC600/24	TSC600/24	TEC600/24
TLCT 700/28	700	761	28	TC700/28	TSC700/28	TEC700/28
TLCT 800/32	800	861	32	TC800/32	TSC800/32	TEC800/32
TLCT 900/36	900	961	36	TC900/36	TSC900/36	TEC900/36
TLCT 1000/40	1000	1061	40	TC1000/40	TSC1000/40	TEC1000/40
TLCT 1100/44	1100	1161	44	TC1100/44	TSC1100/44	TEC1100/44
TLCT 1200/48	1200	1261	48	TC1200/48	TSC1200/48	TEC1200/48
TLCT 1300/52	1300	1361	52	TC1300/52	TSC1300/52	TEC1300/52
TLCT 1400/56	1400	1461	56	TC1400/56	TSC1400/56	TEC1400/56
TLCT 1500/60	1500	1561	60	TC1500/60	TSC1500/60	TEC1500/60

**30 mm resolution -
hand protection**

Cascadable light grids are identified with the abbreviation K in the type and order codes.

For instance, codes for type TLCT-K100/4:

Transmitter: TSC-K100/4
Receiver: TEC-K100/4

Type	Order code					
Complete system	Protective field height (mm)	Length L (mm)	Beam count	Complete system	Transmitter	Receiver
ILCT 100/12	100	161	12	IC100/12	ISC100/12	IEC100/12
ILCT 200/24	200	261	24	IC200/24	ISC200/24	IEC200/24
ILCT 300/36	300	361	36	IC300/36	ISC300/36	IEC300/36
ILCT 400/48	400	461	48	IC400/48	ISC400/48	IEC400/48
ILCT 500/60	500	561	60	IC500/60	ISC500/60	IEC500/60
ILCT 600/72	600	661	72	IC600/72	ISC600/72	IEC600/72
ILCT 700/84	700	761	84	IC700/84	ISC700/84	IEC700/84
ILCT 800/96	800	861	96	IC800/96	ISC800/96	IEC800/96
ILCT 900/108	900	961	108	IC900/108	ISC900/108	IEC900/108
ILCT 1000/120	1000	1061	120	IC1000/120	ISC1000/120	IEC1000/120
ILCT 1100/132	1100	1161	132	IC1100/132	ISC1100/132	IEC1100/132
ILCT 1200/144	1200	1261	144	IC1200/144	ISC1200/144	IEC1200/144
ILCT 1300/156	1300	1361	156	IC1300/156	ISC1300/156	IEC1300/156
ILCT 1400/168	1400	1461	168	IC1400/168	ISC1400/168	IEC1400/168
ILCT 1500/180	1500	1561	180	IC1500/180	ISC1500/180	IEC1500/180

**14 mm resolution -
finger protection with
blanking function**

Cascadable light grids are identified with the abbreviation K in the type and order codes.

For instance, codes for type ILCT-K100/24:

Transmitter: ISC-K100/24
Receiver: IEC-K100/24

Service

If you have any questions that cannot be answered by reading this operating manual, please contact us directly.

When calling, please have the following details ready:

- Device designation
- Serial number
- Fault symptoms and description

Fiessler Elektronik GmbH & Co. KG
Kastellstraße 9
D-73734 Esslingen

Phone: 0711 / 91 96 97 - 0
Fax: 0711 / 91 96 97 - 50
E-mail info@fiessler.de

Maintenance

The devices of the series of ...LCT are maintenance-free.

On request by the customer, Fiessler Elektronik GmbH & Co. KG carries out the acceptance test and annual inspections. In addition, seminars providing customers with training in annual inspections are held at regular intervals.

Warranty

The company Fiessler Elektronik GmbH & Co. KG refuses to accept any warranty claims if the device has been opened or if it has been modified.

Returning a unit

If a unit proves defective and needs to be returned, the following details will greatly help us in repairing the fault quickly:

- Exact fault description
 - Has the machine with the light curtain exhibited other faults?
 - Have you noticed other failures, malfunctions etc. in the past?
 - etc.
- In which operating mode was the machine last used?

The more precise the fault description, the more efficiently and reliably we will be able to pinpoint and eliminate the fault.

Download section

The latest operating manuals, device descriptions etc. can be downloaded free-of-charge from our homepage.

[http:// www.fiessler.de](http://www.fiessler.de)

Additional safety products



Safety switching mats



Safety Footpedal



Parametrizable safety controller **FPSC**



press brakes protection system **AKAS**



Light curtains for safety, control and measurement

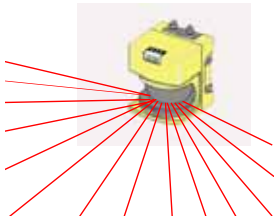

Laser scanners



Single-beam safety light barriers

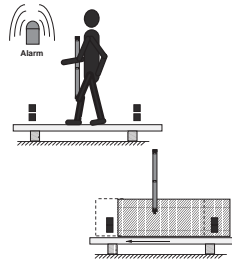

Safety light bars with muting function

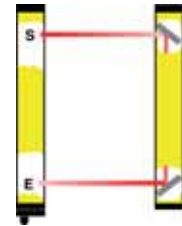

Safety light grids

Service

Safety seminars and integration support by our service team.

Certification

A quality management system was introduced at an early stage to guarantee the high quality of Fiessler safety equipment. Fiessler Elektronik is certified according to DIN ISO EN 9001. The company's own electromagnetic compatibility laboratory tests products on a regular basis. All safety equipment complies with national and European standards. Development takes place in consultation with the relevant trade associations. Certification is received followed rigorous tests by the Technical Inspection Board.



Recognition

by Baden Württemberg's ministry of economy of outstanding performance by the innovative AKAS safety system.



Fiessler Elektronik GmbH & Co. KG
Kastellstr. 9
D-73734 Esslingen

Telefon: ++49(0)7111-91 96 97-0
 Fax: ++49(0)7111-91 96 97-50
 Email: info@fiessler.de
 Internet: www.fiessler.de

Represented in all major countries

