

**Operating instructions**

**24 V DC**



**Nicht mehr  
!Lieferbar!**

**no longer**

**!available!**

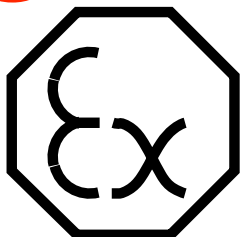

Optional

**CONTENTS**

Safety instructions  
Installation  
Operating instructions  
Technical data

Electrical connection  
Putting into operation

**For 40 years**

we have specialized in the field of  
Opto-electronics.

You gain from our experience.

Tell us your problem.

We will be pleased to offer our advice.

Chapter	Subject	Page
1	<b>Safety instructions</b>	5
2	<b>Terms</b> 	6
3	<b>Requirements for the use of accident-prevention safety light curtains and safety light grids</b>	8
4	<b>Description and fields of application for the equipment</b>	10
4.1	Equipment designations	11
4.2	Description of function of the transmitter and receiver	12
4.3	Description of function of Type LSUW.... switching units LSUW...	13
5	<b>Mechanical data and dimension drawings</b>	
5.1	Transmitters and receivers	15
5.2	Lens arrangement - Receiver	17
5.3	Beam diversion mirrors for safety light curtains and safety light grids	18
5.4	Switching unit	20
5.5	IP 55 surface mounting housing for the switching unit	21
6	<b>Mounting</b>	
6.1	Safety clearance from danger zone	22
6.2	Mounting conditions	24
6.3	Mounting the transmitter and receiver	26
6.4	Recommended means of mounting	27
6.5	Operation with beam diversion mirrors	28
7	<b>Electrical connection</b>	
7.1	<b>General information</b>	30
7.2	<b>Connection diagram for switching unit LSUW NSR 3-1</b>	
7.2.1	General information	31
7.2.2	Operating mode "A" (Protective and control operation with cyclic access to the danger area)	32
7.2.3	Operating mode "B" (Protective operation with restart interlock during the entire cycle)	33
7.2.4	Operating mode "B 1" (Protective operation with restart interlock during the process movement)	34
7.2.5	Operating mode "C" (Protective operation without restart interlock, with valve or contactor control)	35
7.2.6	Operating mode "D" (Protective operation with restart interlock and cyclic testing)	36
7.3	<b>Connection diagram for switching unit LSUW N1k</b>	37
7.4	<b>Connection diagram for switching unit LSUW N1 DUO</b>	
7.4.1	Protection of the danger area with two light barriers	38
7.4.2	Protection of two independent danger areas	39
7.5	<b>Connection diagram for switching unit LSUW N1 Muting</b>	
7.5.1	General information	40
7.5.2	Muting function with four muting sensors and time monitoring	41
7.5.3	Muting function with four muting sensors without time monitoring	42
8	<b>Putting into operation</b>	
8.1	Adjustment instructions	43
8.2	Trouble shooting	44



**The equipment can only be expected to function correctly if these operating instructions and the applicable accident prevention regulations are complied with. These operating instructions are a component of the safety barrier concerned. They must be readily available at the location where the safety barrier is installed.**

**FISSLER**

**ELEKTRONIK**

---



Attention is drawn to all safety instructions by this symbol. Particular attention must be paid to such instructions.

These operating instructions give the user important information concerning the correct use of infrared safety light curtains Types LSUW NSR 3-1, LSUW N 1, LSUW N 1 DUO and LSUW N 1 Muting. These instructions are a component of the safety barrier concerned. It is essential that they be readily available at the location where the safety barrier is installed.

All requirements detailed in these operating instructions must be observed.

Other relevant regulations and the requirements of the employers' liability insurance associations have also to be complied with.

**Read the operating instructions** It is essential that these operating instructions be read before the infrared safety light curtain Type LSUW... is put into operation.

**Qualified persons** The safety light curtain must only be installed, put into operation, serviced and repaired by properly qualified persons.

**Safety warning** Whenever a machine with an LSUW... safety light curtain is operated, it must be ensured before the machine is put into operation that there is nobody within the danger region. A notice to this effect must be displayed on the machine.



Safety light curtains do not provide protection against flying objects that arise from the operation of the machine itself.

The switching unit should be isolated from the electricity supply before it is dismantled. There are parts in the base that conduct electricity.



**Caution, check daily** (at least every 24 hours):

At the beginning of each shift the safety light curtain should be checked as follows:

The light curtain is to be interrupted by passing the test rod\* from one end to the other of the protective field on the transmitter side, in such a manner that the light field is only interrupted by the test rod itself.

As the rod is passed from one end of the protective field to the other, the "free" LED must not light at any time.

\* The diameter of the test rod must be in accordance with the minimum object detection size indicated on the nameplate on the front of the receiver.

**Electrosensitive protective equipment** Type LSUW... safety light curtains and safety light grids are electrosensitive protective equipment (ESPE). The characteristic of ESPE devices is that hazardous movement is interrupted or prevented whenever an object is interposed in the **protective field** generated between a light transmitter and light receiver.

**Safety category 4** Type LSUW... safety light curtains and safety light grids are classified as Safety category 4 devices in accordance with pr EN 954. Safety category 4 devices are self monitoring (ESPE-S) devices that respond without physical contact. They belong to the highest safety class applicable to safety devices that respond without physical contact.

**Self monitoring** By self monitoring is meant that the safety device that responds without physical contact responds also in the event of it itself developing a fault.

**Height of protective field** The height of the protective field generated by the transmitter and receiver combination.

**Width of protective field** The minimum and maximum permissible distance between the transmitter and receiver. The permissible width of protective field is indicated on the LSUW receiver.

**Grid** The distance between the individual lenses is referred to as the grid. Type LSUW... safety light curtains and safety light grids are offered in two alternative versions: with a 15 mm and a 30 mm grid.

**Minimum object detection size** The minimum object detection size indicates the smallest diameter of object that, on its interrupting the light curtain, will be certain to interrupt or prevent hazardous movement. The following minimum object detection sizes are determined by the grid (15 or 30 mm) and the protective field width of the Type LSUW... safety light curtain concerned:

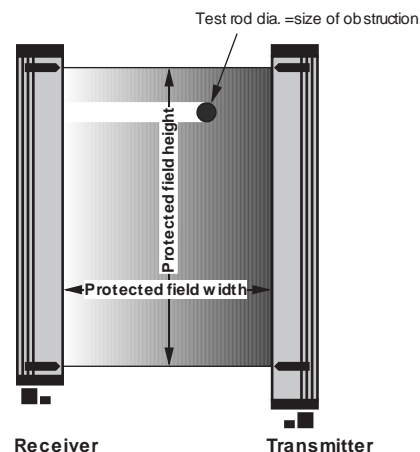

Protective field width in m	0,2-0,5	0,5-1	1-2	1,5-3	2-4	4-6	6-8	8-10	10-12	12-15
Grid 15 mm	20 mm	20 mm	20 mm	25 mm	30 mm	30 mm	40 mm	40 mm	40 mm	–
Grid 30 mm	40 mm	40 mm	40 mm	40 mm	40 mm	50 mm	60 mm	60 mm	70 mm	80 mm

– =Detection cabability

**Beam spacing** The distance between the individual lenses in a Type LSUW... safety light grid is referred to as the beam spacing. Type LSUW... safety light grids are supplied as standard with beam spacings of from 90 mm to 495 mm to suit the nature of the protective field. When required it is possible to supply units with greater beam spacings in steps of 15 mm.

**Safety clearance** To avoid a risk of injury, there needs to be a certain minimum safety clearance  $S$  between the safety light curtain or grid and the nearest point of hazard. To determine the minimum safety clearance it is necessary to refer to the formulae in the European standard EN 999, to the machine-specific C-standards, or to ZH codes of practice that are still valid.

**Overrun** That part of the hazardous machine movement that takes place after entry into the protective field.

**Overrun traverse** The distance traversed during overrun (e.g. by the ram of a press or of a point on the surface of a roller).

**Overrun period** The duration of overrun traverse.

**Response time** The time that elapses between entry into the protective field and the switching operation.

**Valve or contactor monitor** Before every switching-output enable, the contactor monitor checks that the connected switching element (relay, contactor or valve) has dropped out. Only if this is the case can the switching output be enabled. This avoids any possibility of hazards arising from failure of the switching element (relay, contactor or valve) that controls the hazardous movement of the machine concerned.

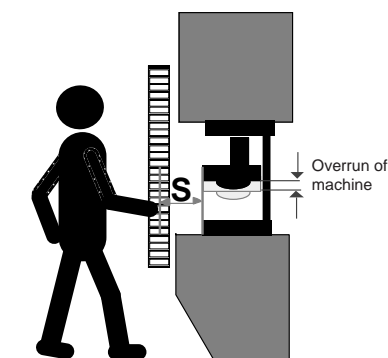

**Start interlock** On the machine being put into operation, respectively any interruption in the power supply, the start interlock feature prevents the machine from starting before a second "enable". Such a second enable of the switching output is only possible after entry into and withdrawal from the protective field.

**Restart interlock** The restart interlock feature prevents an automatic enable of the switching output after entry into and withdrawal from the protective field (e.g. by passing through the protective field).

**1-stroke (2-stroke) operation** In this mode, the machine starts an operation cycle after the operator has reached into the protective field once (twice). If then the operation is repeated within 30 seconds the machine starts another cycle. If there is a delay of more than 30 seconds, the restart interlock is activated.

**Protective operation** Entry into the protective field causes the switching outputs to be disabled. They are enabled again automatically on withdrawal from the protective field.

**Muting** This operating mode allows for safe, brief interruptions of a Type LSUW safety light curtain for material movements, e.g. into and out of a production cell or high-bay warehouse. A clear distinction is made between the entry of a person and material.

**EN 50100-1 (Appendix C, Mounting, putting into operation and testing of a ESPE on a machine)**

- The sensor function must be capable of eliminating the hazardous state of the machine.
- The safety clearance between the protective field and the point of hazard must be sufficient to ensure that if the protective field is penetrated, it will not be possible to reach the point of hazard before the hazardous movement is interrupted or has stopped.
- Access to the point of hazard must only be possible by penetrating the protective field (reaching below, above or around it must not be possible)
- Passing through the protective field must not be possible. If it is possible to pass through the protective field, then its interruption must cause the restart interlock to be activated so that the start pushbutton has to be pressed again before a command to initiate a subsequent hazardous movement can be executed. This start pushbutton must be in a position from which there is an unobstructed view of the accessible region.
- Unintended repetition of a hazardous machine movement must be prevented with the necessary certainty.
- The safety category (Category 4) of the safety light barrier must be at least equivalent to that of the machine control.
- Acceptance inspection:  
The acceptance inspection of the mounting of the equipment and its testing must be effected by a competent person who has access to all the information provided by the maker of the machine concerned and of the ESPE.
- Yearly inspection;  
The company operating the plant must ensure that a competent person is named who will inspect the light barrier annually. The person concerned may be an employee of the light-barrier manufacturer or of the company that operates the plant concerned.



When requested, the firm of Fiessler Elektronik is prepared to perform the acceptance and annual inspections. It also offers training seminars at regular intervals to train customers' staff to perform annual inspections.



**prEN 999** The flow diagram below will be helpful in determining the correct safety clearance for a particular application. Some of the calculation formulae contained in prEN 999 are quoted in Chapter 6 of these operating instructions. (The position of protective equipment in respect of approach speeds of parts of the human body)



**To determine the necessary safety clearances, the user must refer to the standard applicable to the specific machine.**

Procedure for determining the safety clearance between the protective device and the point of hazard in accordance with the specified standards for the machine concerned:

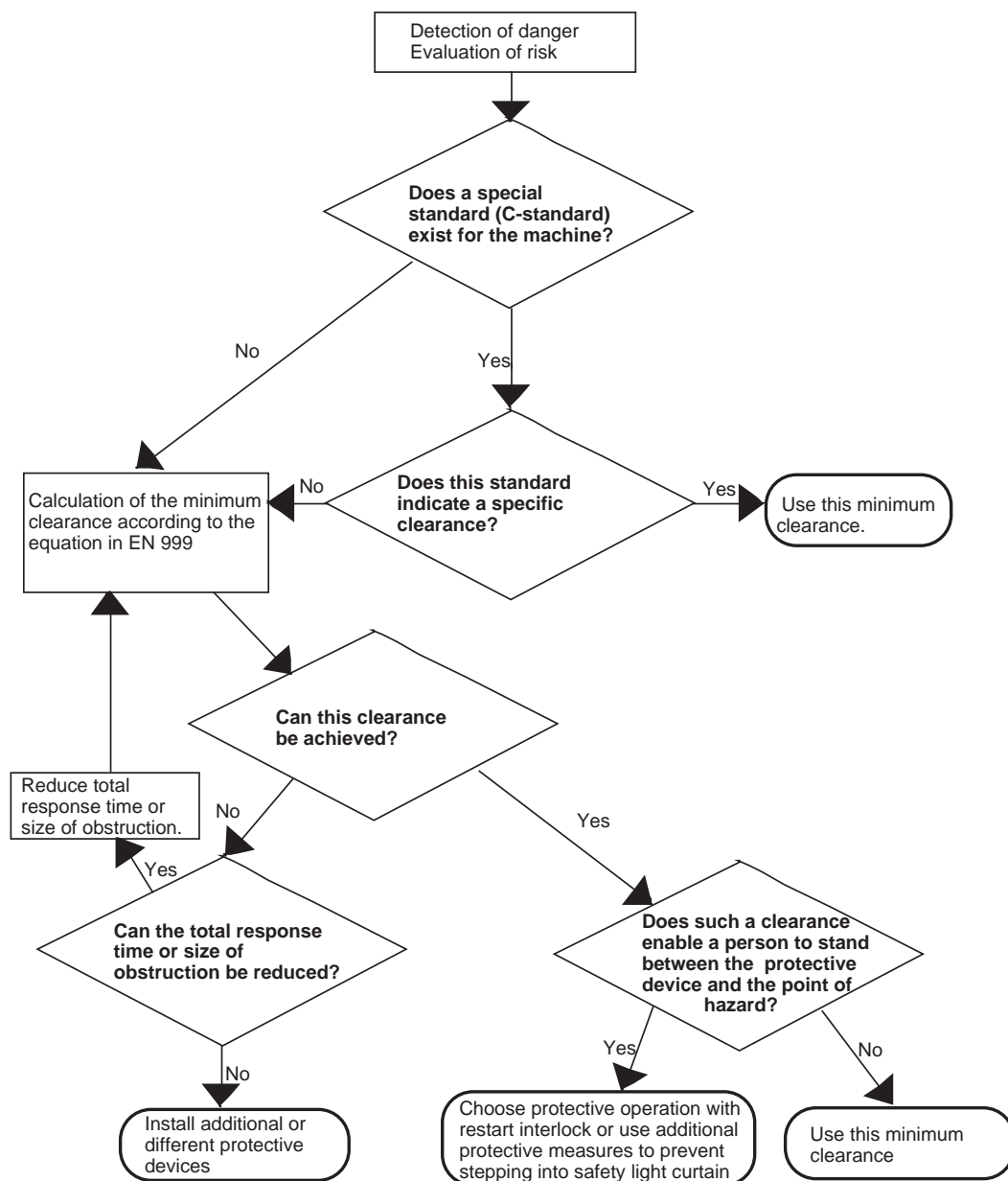

Infrared accident-prevention and control light barriers Type LSUW... are electrosensitive protective equipment (ESPE) whose purpose is to protect persons from injury.

This is effected by so screening the power-driven machinery in such a manner that access to hazardous machine parts is only possible by penetrating the protective field provided by the light barrier.

Penetration of the protective field brings the machine to a stop with certainty and in good time.

Infrared accident-prevention and control light barriers Type LSUW...

- have been tested by the Technical Supervision Association (TÜV) and approved by the Employers' Liability Insurance Associations
- meet the requirements of EN 50100 for Category 4 devices
- are self monitoring without additional circuitry
- are of compact dimensions and are easy to mount and adjust
- have proved their worth over many years
- are programmable for all modes of operation including muting
- optional in EXX-p

Typical fields of application for infrared accident-prevention and control light barriers Type LSUW... are the protection of:

- Presses for the processing of metal, wood, plastics, rubber, leather and glass
- Filter presses
- Edging and bending presses
- Injection moulding machines
- Machining centers and press-type welders
- Automatic component-insertion machines
- Robot systems

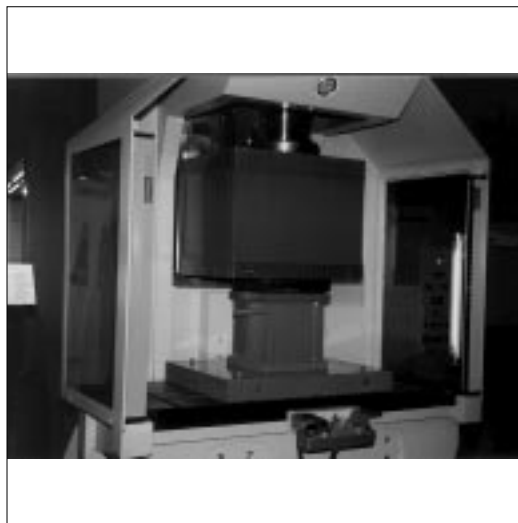

**Guarding of presses**

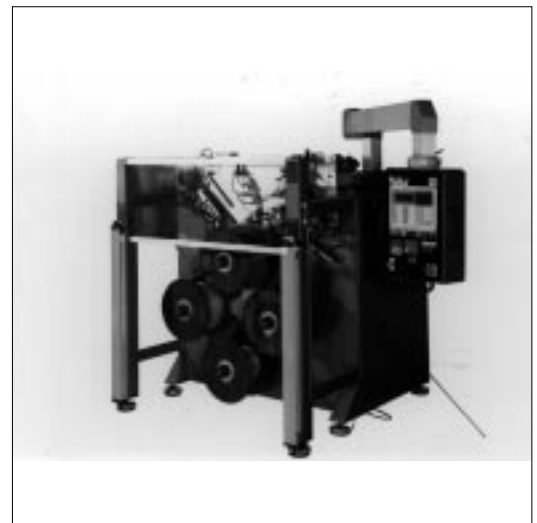

**Guarding of a wiring harness assembler**



**Guarding of access regions**

Arrangement of Type plates

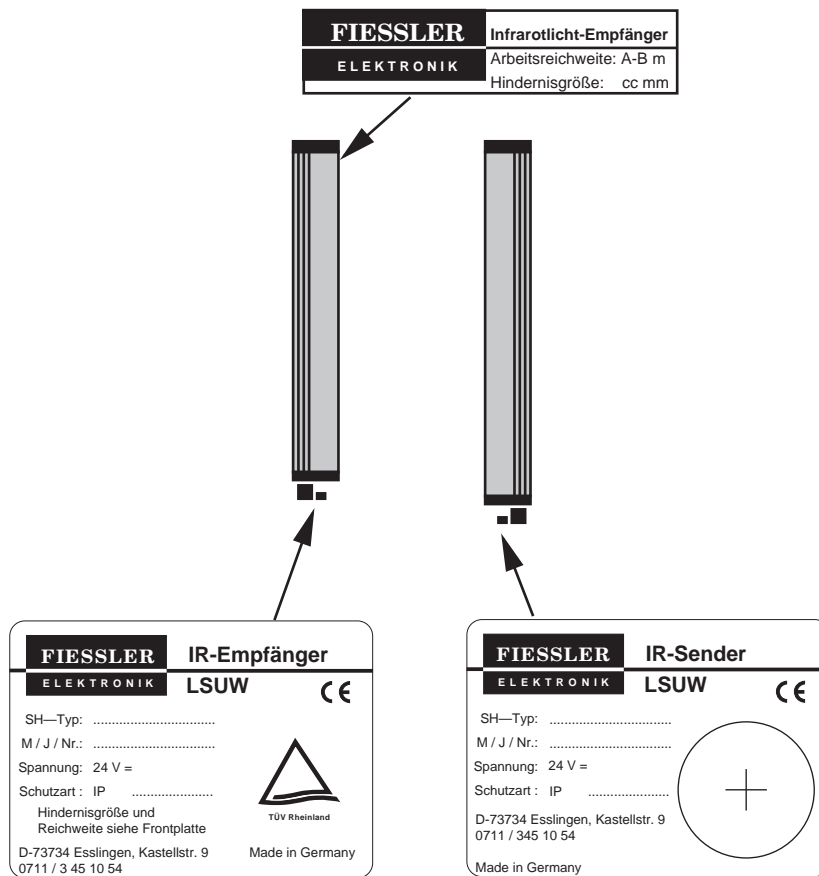

Serial number code for receivers and transmitters

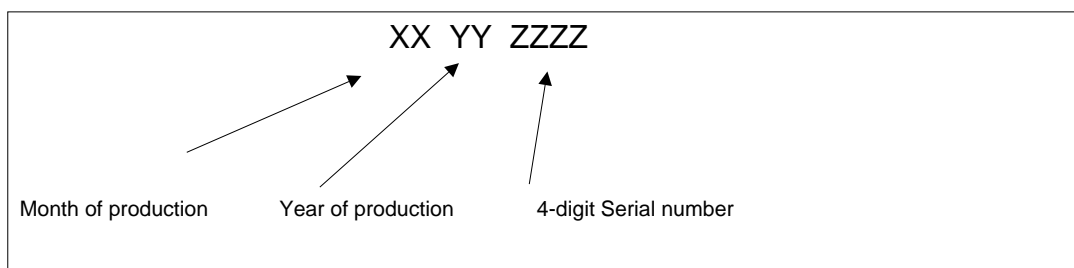

Serial number code for switching units

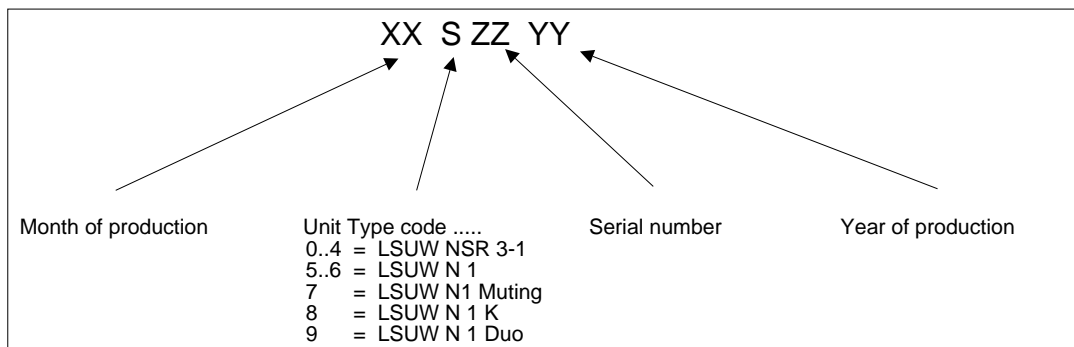

A Type LSUW... safety light barrier system comprises the three components, light transmitter, receiver and switching device. The system is designed as a unit-assembly system. All components with the Type designation LSUW... can be combined one with another.

Receivers with sensors at various grids and various versions of switching device are offered to provide for differing accident-prevention requirements.

**Transmitter** The transmitter generates an invisible band of alternating infrared light.

**Receiver** The receiver consists of a number of optical modules spaced at a grid of 15 or 30 mm or at a beam spacing of  $\geq 90$  mm.

Through a specially focussed optical system the optical modules only detect that part of the light band that is immediately opposite to them. The modules are connected in series and their output is modulated with a carrier frequency.

In the event of the protective field being penetrated, the chain of signals is interrupted and this results in the evaluation unit generating two antivalent signals which are transmitted to the switching unit. Various versions of switching unit are offered to provide for the protection of the operators of machines that differ widely in character.

**Function diagram**

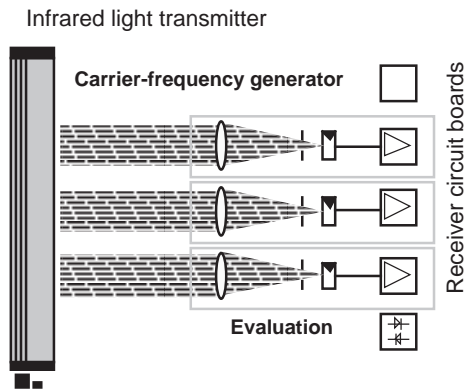

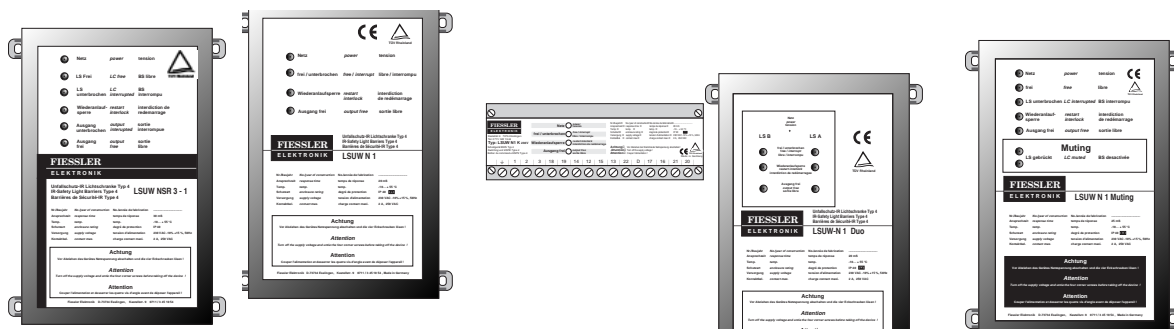

Switching unit LSUW NSR 3-1 programmable  
LSUW N1

LSUW N1 K

Switching unit LSUW N1 Duo for connection of two ESPE

Switching unit LSUW N1 Muting for disabling function

Switching unit	LSUW NSR 3-1 programmable	LSUW N1 LSUW N1 K	LSUW N1 Duo	LSUW N1 Muting
Function				
Light grid monitoring	X	X	X	X
Start interlock	X	X	X	X
Restart interlock	X	X	X	X
Valve or contactor monitoring	X	X	X	X
Protective and monitoring operation with cyclic reaching into the protective field (1-step)	X			
Protective and monitoring operation with cyclic reaching into the protective field (2-step)	X			
Protective operation with restart interlock during the entire cycle	X	X	X	X
Protective and control operation with restart interlock during the process movement	X			
Protective operation without restart interlock, with valve or contactor monitoring	X			
Protective operation with restart interlock and cyclic testing	X			
Two monitored normally-open contacts for control of the subsequent working machine	X	X	X	X
Provision for connecting two ESPE			X	
Provision for connecting a operating mode selector switch	X			
Programmable functions	X			
Disabling (Muting) function				X

Functions provided by the switching unit type concerned: X

- Housing execution:** Aluminium extrusion, plastic coated RAL 1020 yellow, end pieces of acid-resistant plastic (Polyamide). Light outlets and light inlets of acrylic resin, optionally of solvent-resistant silica glass.
- Fastening:** Moveable key blocks for fitting on any of three sides of the housing
- Degree of protection:** IP 55, optionally IP 65
- Electrical connection:** DIN 43650 plug

**Dimensions:**

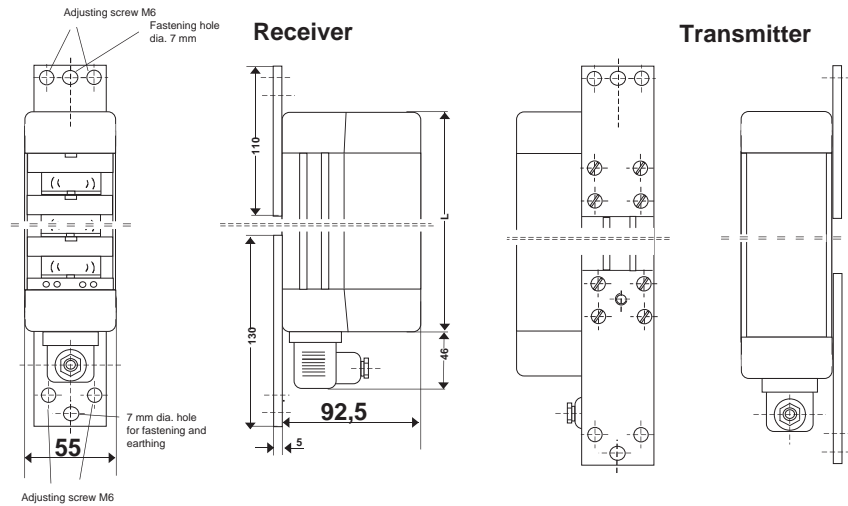

**Fastening straps**

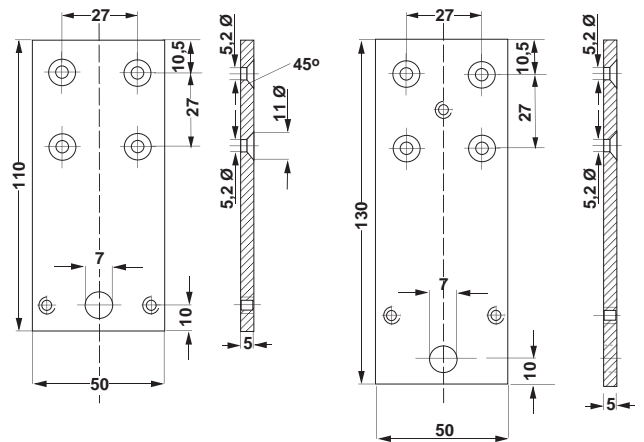

**Overall dimensions Safety light curtains LSUW...:**

Receiver	Overall length L	Weight	Protection space height in accordance to Norm	Order designation	Protection space height in accordance to Norm	Order designation	Transmitter	Overall length L	Weight	Order designation
			Grid 15 mm	IR-receiver LSUW ...	Grid 30 mm	IR-receiver LSUW ...				
226 mm	1110 g	145 mm	...120/9	180 mm	...120/5	256 mm	1110 g	...120		
314 mm	1550 g	230 mm	...235/15	270 mm	...235/8	344 mm	1410 g	...235		
464 mm	2300 g	380 mm	...355/25	390 mm	...355/12	494 mm	2200 g	...355		
616 mm	2800 g	535 mm	...505/35	540 mm	...505/17	646 mm	2700 g	...505		
766 mm	3500 g	680 mm	...685/45	720 mm	...685/23	796 mm	3100 g	...685		
996 mm	4500 g	910 mm	...895/60	930 mm	...895/30	1026 mm	3800 g	...895		
1226 mm	5300 g	1130 mm	...1135/75	1170 mm	...1135/38	1256 mm	4900 g	...1135		
1526 mm	6500 g	1430 mm	...1435/95	1465 mm	...1435/48	1556 mm	5700 g	...1435		
1697 mm	7850 g	1610 mm	...1600/107	1645 mm	...1600/54	1736 mm	6990 g	...1600		
1940 mm	8970 g	mm	---	1855 mm	...1800/61	1970 mm	7930 g	...1800		
2012 mm	9310 g	mm	---	2065 mm	...2000/68	2042 mm	8220 g	...2000		

Overall dimensions  
2-beam, 3-beam and multi-beam  
Safety light grids LSUW...:

Height of protection	Number of light beams	Distance between light beams	Receiver		Order designation	Transmitter		Order designation
			Overall length L	Weight	IR-receiver LSUW ...	Overall length L	Weight	IR-transmitter LSUW ...
					...			
505 mm	2	480 mm	616 mm	2800 g	...505/2	646 mm	2700 g	505
505 mm	3	255 mm	616 mm	2800 g	...505/3	646 mm	2700 g	505
505 mm	4	165 mm	616 mm	2800 g	...505/4	646 mm	2700 g	505
505 mm	5	120 mm	616 mm	2800 g	...505/5	646 mm	2700 g	505
505 mm	6	90 mm	616 mm	2800 g	...505/6	646 mm	2700 g	505
685 mm	3	330 mm	766 mm	3500 g	... 685/3	796 mm	3100 g	685
685 mm	4	210 mm	766 mm	3500 g	... 685/4	796 mm	3100 g	685
685 mm	5	165 mm	766 mm	3500 g	... 685/5	796 mm	3100 g	685
685 mm	6	120 mm	766 mm	3500 g	... 685/6	796 mm	3100 g	685
685 mm	7	105 mm	766 mm	3500 g	... 685/7	796 mm	3100 g	685
685 mm	8	90 mm	766 mm	3500 g	... 685/8	796 mm	3100 g	685
895 mm	3	405 mm	996 mm	4500 g	... 895/3	1026 mm	3800 g	895
895 mm	4	285 mm	996 mm	4500 g	... 895/4	1026 mm	3800 g	895
895 mm	5	210 mm	996 mm	4500 g	... 895/5	1026 mm	3800 g	895
895 mm	6	165 mm	996 mm	4500 g	... 895/6	1026 mm	3800 g	895
895 mm	7	135 mm	996 mm	4500 g	... 895/7	1026 mm	3800 g	895
895 mm	8	120 mm	996 mm	4500 g	... 895/8	1026 mm	3800 g	895
895 mm	9	105 mm	996 mm	4500 g	... 895/9	1026 mm	3800 g	895
895 mm	10	90 mm	996 mm	4500 g	... 895/10	1026 mm	3800 g	895
1135 mm	4	360 mm	1226 mm	5300 g	... 1135/4	1256 mm	4900 g	1135
1135 mm	5	270 mm	1226 mm	5300 g	... 1135/5	1256 mm	4900 g	1135
1135 mm	6	210 mm	1226 mm	5300 g	... 1135/6	1256 mm	4900 g	1135
1135 mm	7	180 mm	1226 mm	5300 g	... 1135/7	1256 mm	4900 g	1135
1135 mm	8	150 mm	1226 mm	5300 g	... 1135/8	1256 mm	4900 g	1135
1135 mm	9	135 mm	1226 mm	5300 g	... 1135/9	1256 mm	4900 g	1135
1135 mm	10	120 mm	1226 mm	5300 g	... 1135/10	1256 mm	4900 g	1135
1135 mm	11	105 mm	1226 mm	5300 g	... 1135/11	1256 mm	4900 g	1135
1135 mm	12	90 mm	1226 mm	5300 g	... 1135/12	1256 mm	4900 g	1135
1435 mm	4	465 mm	1526 mm	6500 g	... 1435/4	1556 mm	5700 g	1435
1435 mm	5	345 mm	1526 mm	6500 g	... 1435/5	1556 mm	5700 g	1435
1435 mm	6	270 mm	1526 mm	6500 g	... 1435/6	1556 mm	5700 g	1435
1435 mm	7	225 mm	1526 mm	6500 g	... 1435/7	1556 mm	5700 g	1435
1435 mm	8	195 mm	1526 mm	6500 g	... 1435/8	1556 mm	5700 g	1435
1435 mm	9	165 mm	1526 mm	6500 g	... 1435/9	1556 mm	5700 g	1435
1435 mm	10	150 mm	1526 mm	6500 g	... 1435/10	1556 mm	5700 g	1435
1435 mm	11	135 mm	1526 mm	6500 g	... 1435/11	1556 mm	5700 g	1435
1435 mm	12	120 mm	1526 mm	6500 g	... 1435/12	1556 mm	5700 g	1435
1435 mm	14	105 mm	1526 mm	6500 g	... 1435/14	1556 mm	5700 g	1435
1435 mm	16	90 mm	1526 mm	6500 g	... 1435/16	1556 mm	5700 g	1435

Overall dimensions  
2-beam, 3-beam and multi-beam  
Safety light grids LSUW...  
(continued):

Height of protection	Number of light beams	Distance between light beams	Receiver		Order designation	Transmitter		Order designation
			Overall length L	Weight	IR-receiver LSUW ...	Overall length L	Weight	IR-transmitter LSUW ...
1600 mm	5	390 mm	1697 mm	7850 g	... 1600/5	1727 mm	6990 g	1600
1600 mm	6	315 mm	1697 mm	7850 g	... 1600/6	1727 mm	6990 g	1600
1600 mm	7	255 mm	1697 mm	7850 g	... 1600/7	1727 mm	6990 g	1600
1600 mm	8	225 mm	1697 mm	7850 g	... 1600/8	1727 mm	6990 g	1600
1600 mm	9	195 mm	1697 mm	7850 g	... 1600/9	1727 mm	6990 g	1600
1600 mm	10	165 mm	1697 mm	7850 g	... 1600/10	1727 mm	6990 g	1600
1600 mm	11	150 mm	1697 mm	7850 g	... 1600/11	1727 mm	6990 g	1600
1600 mm	12	135 mm	1697 mm	7850 g	... 1600/12	1727 mm	6990 g	1600
1600 mm	14	120 mm	1697 mm	7850 g	... 1600/14	1727 mm	6990 g	1600
1600 mm	16	105 mm	1697 mm	7850 g	... 1600/16	1727 mm	6990 g	1600
1600 mm	18	90 mm	1697 mm	7850 g	... 1600/18	1727 mm	6990 g	1600
1800 mm	5	450 mm	1940 mm	8970 g	... 1800/5	1970 mm	7930 g	1800
1800 mm	6	360 mm	1940 mm	8970 g	... 1800/6	1970 mm	7930 g	1800
1800 mm	7	300 mm	1940 mm	8970 g	... 1800/7	1970 mm	7930 g	1800
1800 mm	8	255 mm	1940 mm	8970 g	... 1800/8	1970 mm	7930 g	1800
1800 mm	9	225 mm	1940 mm	8970 g	... 1800/9	1970 mm	7930 g	1800
1800 mm	10	195 mm	1940 mm	8970 g	... 1800/10	1970 mm	7930 g	1800
1800 mm	11	180 mm	1940 mm	8970 g	... 1800/11	1970 mm	7930 g	1800
1800 mm	13	150 mm	1940 mm	8970 g	... 1800/13	1970 mm	7930 g	1800
1800 mm	14	135 mm	1940 mm	8970 g	... 1800/14	1970 mm	7930 g	1800
1800 mm	16	120 mm	1940 mm	8970 g	... 1800/16	1970 mm	7930 g	1800
1800 mm	18	105 mm	1940 mm	8970 g	... 1800/18	1970 mm	7930 g	1800
1800 mm	21	90 mm	1940 mm	8970 g	... 1800/21	1970 mm	7930 g	1800
2000 mm	5	495 mm	2012 mm	9310 g	... 2000/5	2042 mm	8220 g	1800
2000 mm	6	390 mm	2012 mm	9310 g	... 2000/6	2042 mm	8220 g	1800
2000 mm	7	330 mm	2012 mm	9310 g	... 2000/7	2042 mm	8220 g	1800
2000 mm	8	285 mm	2012 mm	9310 g	... 2000/8	2042 mm	8220 g	1800
2000 mm	9	240 mm	2012 mm	9310 g	... 2000/9	2042 mm	8220 g	1800
2000 mm	10	210 mm	2012 mm	9310 g	... 2000/10	2042 mm	8220 g	1800
2000 mm	11	195 mm	2012 mm	9310 g	... 2000/11	2042 mm	8220 g	1800
2000 mm	12	180 mm	2012 mm	9310 g	... 2000/12	2042 mm	8220 g	1800
2000 mm	13	165 mm	2012 mm	9310 g	... 2000/13	2042 mm	8220 g	1800
2000 mm	14	150 mm	2012 mm	9310 g	... 2000/14	2042 mm	8220 g	1800
2000 mm	15	135 mm	2012 mm	9310 g	... 2000/15	2042 mm	8220 g	1800
2000 mm	17	120 mm	2012 mm	9310 g	... 2000/17	2042 mm	8220 g	1800
2000 mm	20	105 mm	2012 mm	9310 g	... 2000/20	2042 mm	8220 g	1800
2000 mm	23	90 mm	2012 mm	9310 g	... 2000/23	2042 mm	8220 g	1800

Order designation for complete systems comprising a transmitter, receiver and switching unit:

Order designation	Switching unit	LSUW NSR 3-1 programmable	LSUW N1 LSUW N1K	LSUW N1 Duo	LSUW N1 Muting
... (see receiver)		LSUW NSR 3-1...	LSUW N1... LSUW N1 K...	LSUW N1 Duo...	LSUW N1 Muting...

**Example 1:**

The complete system LSUW N1 895/3 comprises the IR receiver LSUW 895/3 (Protective height 895 mm, number of beams: 3), The IR transmitter LSUW 895 and the switching unit LSUW N1.

**Example 2:**

The complete system LSUW NSR 3-1 1435/95 comprises the IR receiver LSUW 1435/95, (Protective height 1435 mm, grid: 15 mm), The IR transmitter LSUW 1435 and the switching unit LSUW NSR 3-1.

When ordering please be certain to state the protective field width, see also the table in Chapter 6.1.



Lens arrangement  
(Receiver)

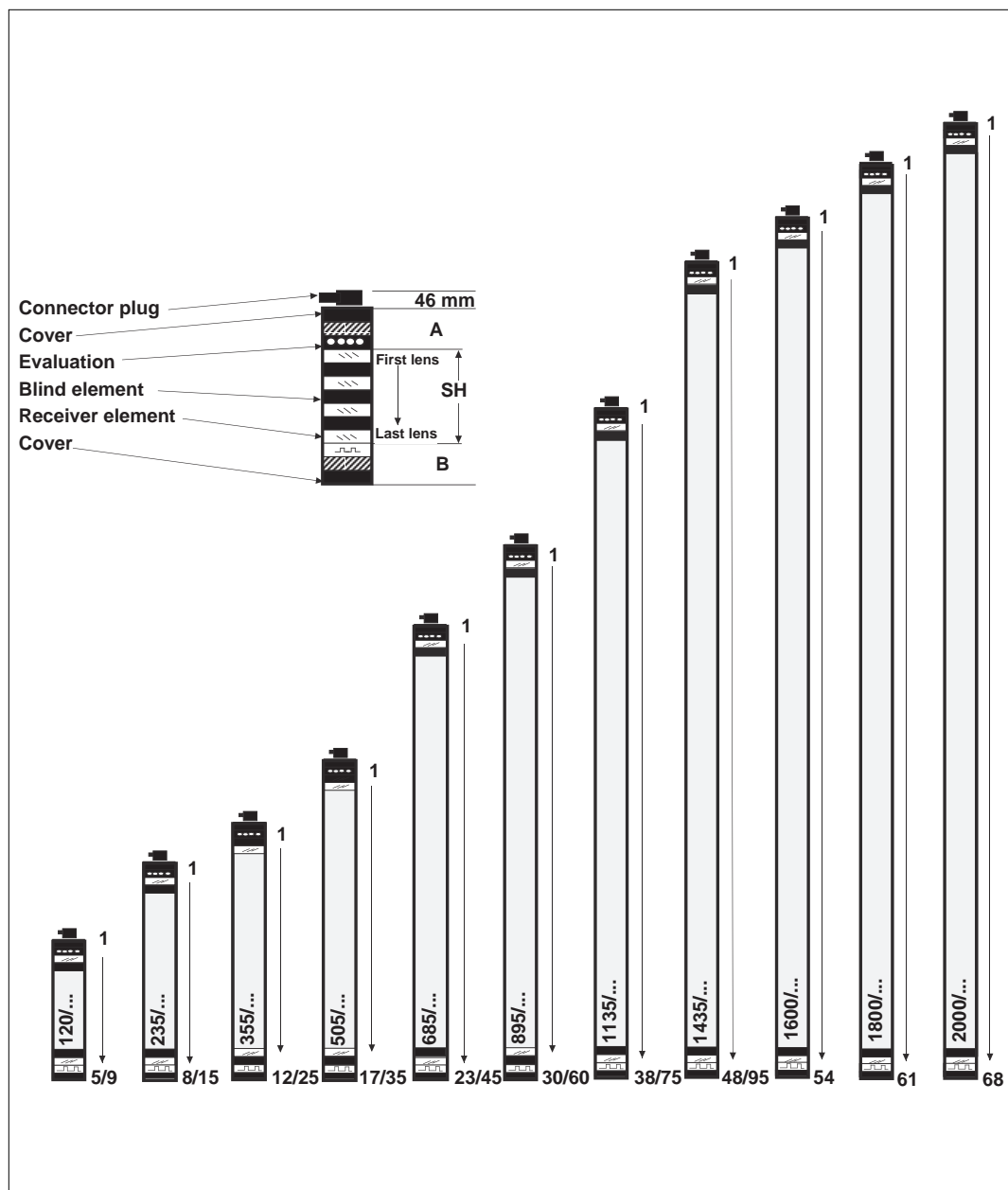

Minimum distance  
between fastenings

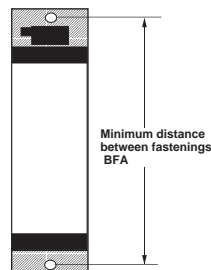

Receiver	Typ	120/...	235/...	355/...	505/...	685/...	895/...	1135/...	1435/...	1600/...	1800/...	2000/...
A: mm		45	50	65	60	50	50	50	50	35	35	35
SH: mm		136	221	351	496	673	882	1122	1422	1627	1839	2049
B: mm		45	45	50	60	45	60	45	45	35	35	35
BFA: mm		266	356	506	656	808	1032	1257	1557	1737	1949	2159

Transmitter	Typ	120	235	355	505	685	895	1135	1435	1600	1800	2000
BFA: mm		296	386	536	686	838	1062	1287	1587	1767	1979	2189

For overall lengths of transmitters and receivers see Pages 14-16

**Housing execution:** Distortion-proof aluminium dual-chamber extrusion, plastic coated RAL 1021 yellow  
**Fastening:** Ball-head screw

Dimension drawing:

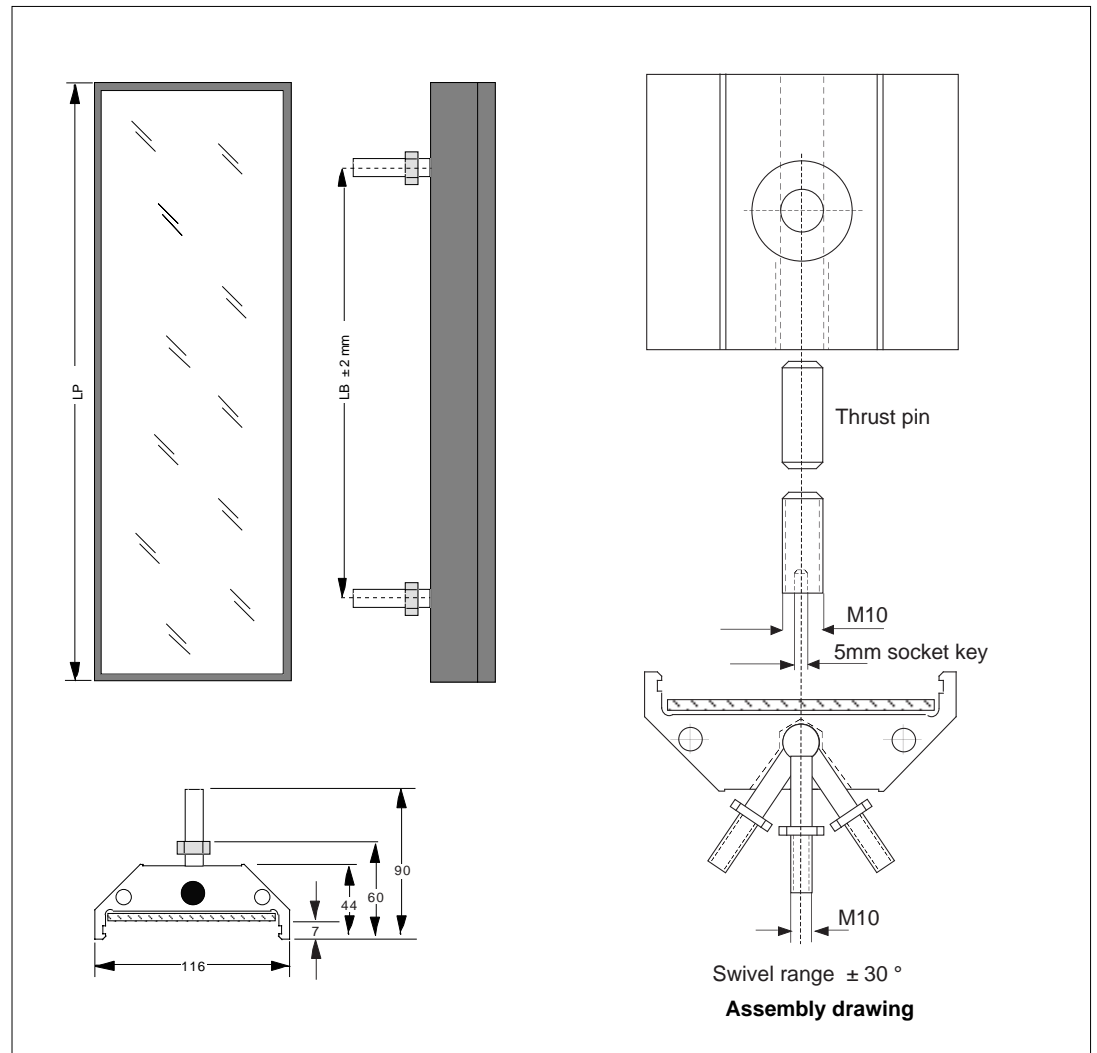

**Overall dimensions:**

	120	235	355	505	685	895	1135	1435	1600	1800	2000
<b>For protective height</b>											
<b>Length of extrusion LP</b>	205	315	465	618	765	995	1.210	1.510	1.710	1.910	2.110
<b>Distance between fastenings LB</b>	centre*	210	360	513	660	890	1.105	1.405	1.605	1.805	2.005
<b>Weight g</b>	1.699	2.392	3.337	4.300	5.227	6.676	8.030	9.920	11.180	12.440	13.700

\* Fastening only by one ball-pivot

**Mounting instructions:**

1. Insert the ball-head screw in the pocket opening as shown in the drawing.
2. Insert the thrust pin.
3. Screw in the socket-head grub screw and tighten it using a 5 mm socket screw key.

The ball head screw can then be used for fastening to some suitable mounting.

There is also a possibility of fastening the mirrors by means of the threaded hole in the aluminium extrusion.

**NSR 3-1, N1, N1 DUO,  
N1 Muting**

**Housing execution:** ABS plastic, RAL 1020 yellow

**Fastening:** 4 holes in the mounting base, see drawing

**Protection:** Switch cabinet version IP 40. A higher degree of protection IP 55 is provided by the wall mounting version.

**Electrical connection:** Plug-in connection in base.

**Weight:** 2550 g

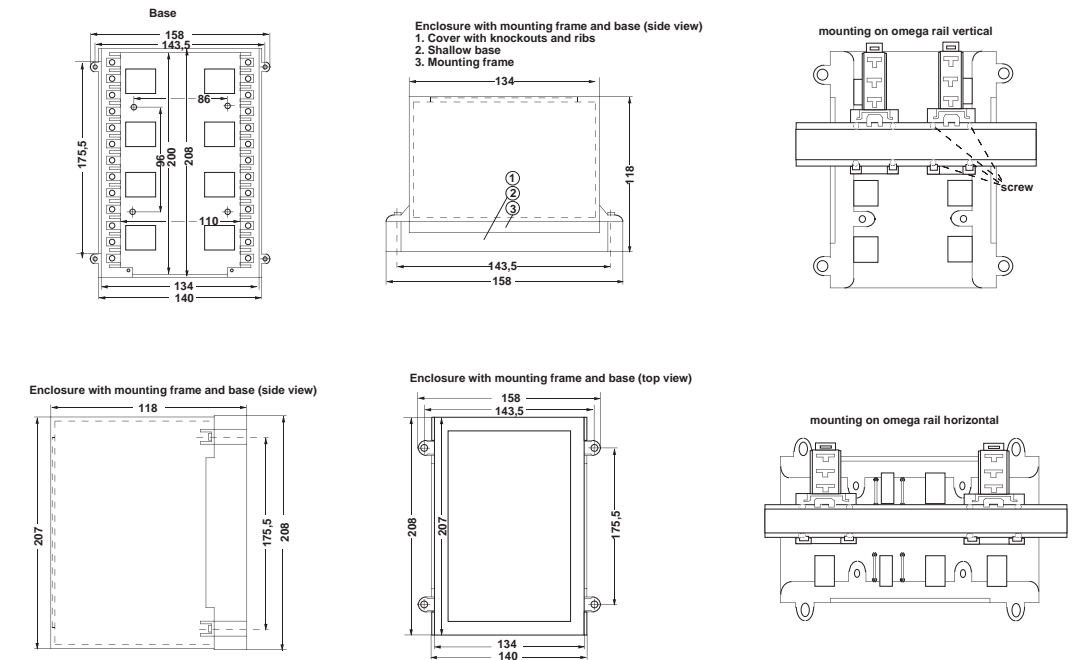

**N1 K**

**Housing execution:** Isolating case, black, cover beige colored

**Fastening:** Snap-on mounting on omega rail DIN EN 50022-35, screw-connection M4 screw 80 mm

**Protection:** IP 40

**Electrical connection:** Electrical connection; Plug-in connection in rail

**Weight:** 800 g

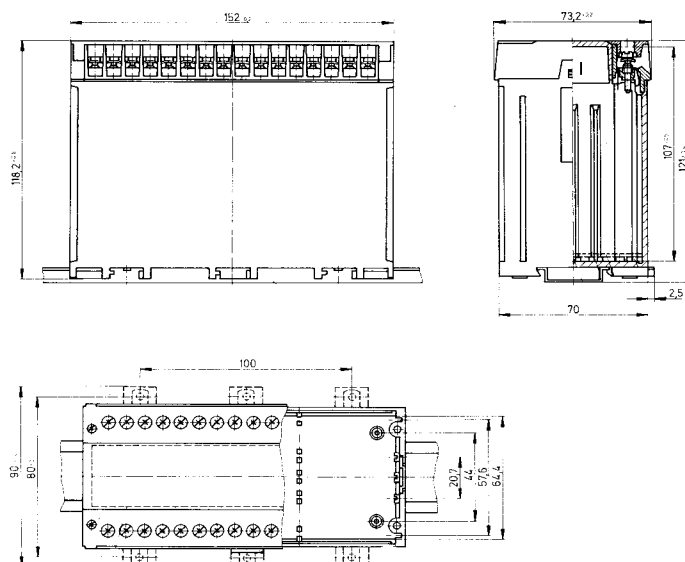

Housing execution: Base, grey plastic. Cover transparent Makrolon.  
 Fastening: 4 holes in the mounting base  
 Protection: IP 55  
 Electrical connection: Cable passage through PG cable gland  
 Weight: 800 g

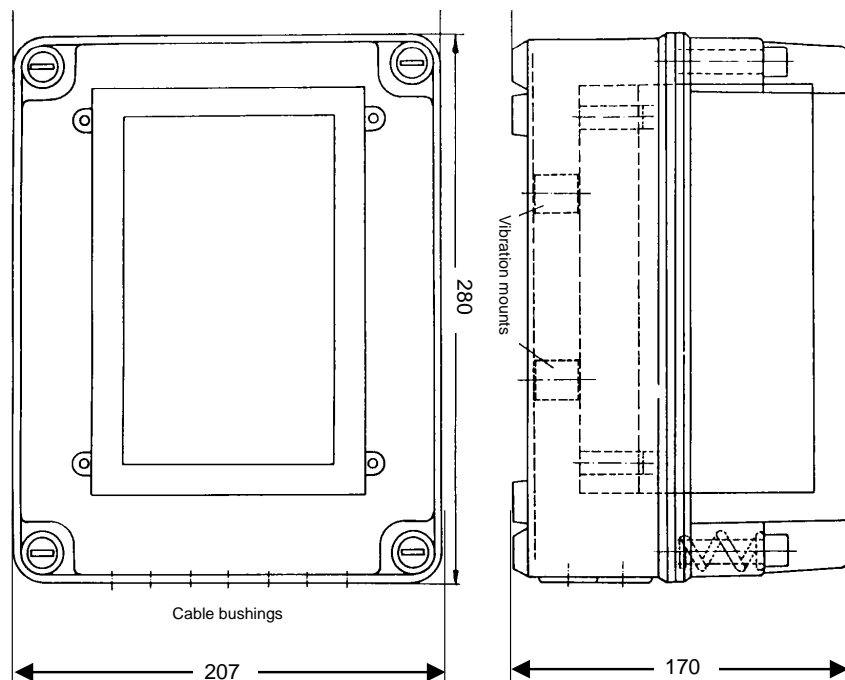
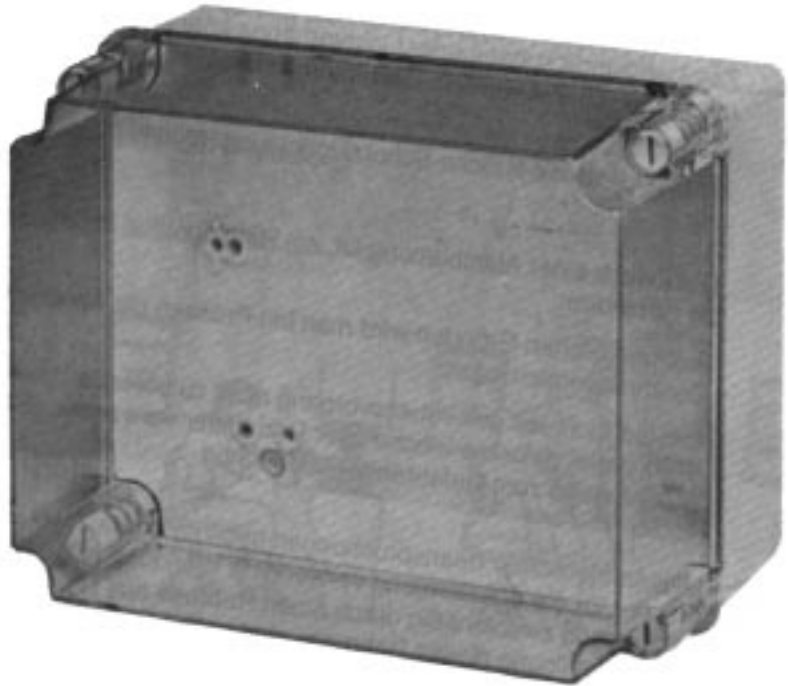

### General mounting instructions



The safety clearance **S** between the safety light curtain and the point of hazard must be sufficient to ensure that if the protective field is penetrated it will not be possible to reach the point of hazard before the hazardous movement is brought to a stop. In this connection reference should also be made to EN 999 and to any relevant national and international safety regulations.

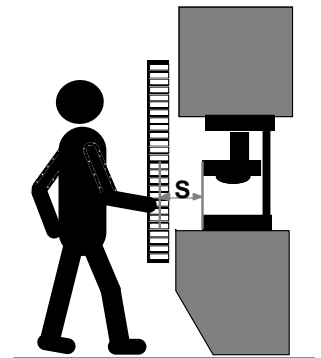

### Safety clearance

The safety clearance **S** (in mm) depends upon:

- Speed of reach-in **K**
- Response time of protection device **t1**  
(For Type LSUW... safety light curtains, irrespective of the overall length, this is 20 ms with Switching unit LSUW N1... and 30 ms with Switching unit LSUW NSR 3-1)
- The overrun time of the machine concerned **t2**  
(to be indicated by the machine manufacturer)
- Minimum size of detectable obstruction **d**

The total response time **T** is determined from the response time of the protective device **t1** and the overrun time of the machine **t2**  
**T = t1+t2**

The minimum size of detectable obstruction **d** depends on the protective field width:

Protective field width in m	0,2-0,5	0,5-1	1-2	1,5-3	2-4	4-6	6-8	8-10	10-12	12-15
Grid 15 mm	20 mm	20 mm	20 mm	25 mm	30 mm	30 mm	40 mm	40 mm	40 mm	–
Grid 30 mm	40 mm	40 mm	40 mm	40 mm	40 mm	50 mm	60 mm	60 mm	70 mm	80 mm

=Detection capability

### Formula for calculation of the safety clearances required for safety light barriers

$$S = (1600 \text{ mm} / s \cdot T) + 8(d-14) \quad S > 500\text{mm}$$

$$S = (2000 \text{ mm} / s \cdot T) + 8(d-14) \quad 100\text{mm} \leq S \leq 500\text{mm}$$

Example:

Overrun time of the machine: 75 ms

The safety clearance required for a safety light curtain Type LSUW... with a **15 mm grid**, a Type LSUW N1 switching unit and an obstruction size of 20 mm would be

$$S = (2000 \text{ mm/s} \cdot 0.095 \text{ s}) + 8(20-14)$$

$$S = 238 \text{ mm}$$

The safety clearance required for a safety light curtain Type LSUW... with a **30 mm grid**, a Type LSUW N1 switching unit and an obstruction size of 40 mm would be

$$S = (2000 \text{ mm/s} \cdot 0.095 \text{ s}) + 8(40-14)$$

$$S = 398 \text{ mm}$$

Example:

Overrun time of the machine: 275 ms

The safety clearance required for a safety light curtain Type LSUW... with a **15 mm grid**, a Type LSUW N1 switching unit and an obstruction size of 20 mm would be

$$S = (1600 \text{ mm/s} \cdot 0.295 \text{ s}) + 8(20-14)$$

$$S = 520 \text{ mm}$$

The safety clearance required for a safety light curtain Type LSUW... with a **30 mm grid**, a Type LSUW N1 switching unit and an obstruction size of 40 mm would be

$$S = (1600 \text{ mm/s} \cdot 0.295 \text{ s}) + 8(40-14)$$

$$S = 680 \text{ mm}$$

Formula for calculation of the safety clearances required for safety light barriers with multiple separate beams

$$S = (1600 \text{ mm} / \text{s} \cdot T) + 850 \text{ mm}$$

Example: Overrun time of the machine: 75 ms

The safety clearance required for a safety light curtain Type LSUW... with **3 light beams** and a Type LSUW N1 switching unit would be

$$S = (1600 \text{ mm/s} \cdot 0.095 \text{ s}) + 850 \text{ mm}$$

$$S = 1002 \text{ mm}$$

Arrangement of the individual beams

Number of beams: 4

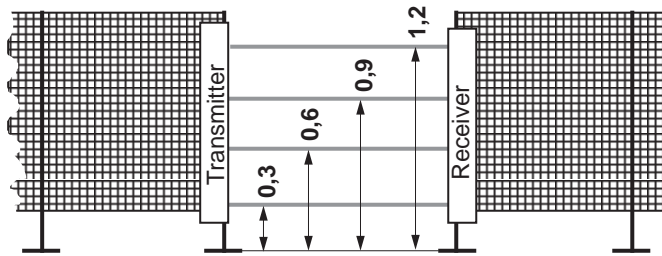

Height above reference level

Number of beams: 3

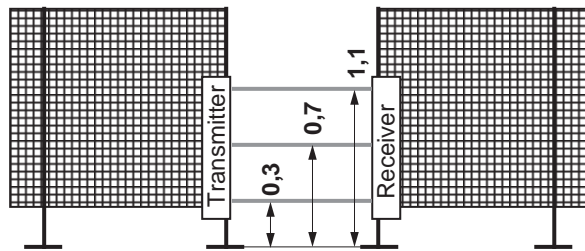

Number of beams: 2

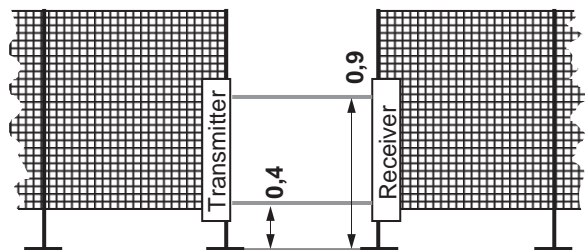

**Mounting without guarding**

A light curtain is formed between the light transmitter (a) and the light receiver (b). In the event of the beam of light being interrupted, possibly by a hand, the interruption of the control current circuit prevents or stops the closing movement of the press.

In this example it is not possible to circumvent the LSUW infrared safety light curtain from the operator side and so no additional guarding is needed at the front. It can be seen that the height of the curtain is of the utmost importance.

To ensure that it is impossible to get between the safety light curtain and the machine it is necessary that the free space between the light curtain and the machine is  $\leq 75$  mm.

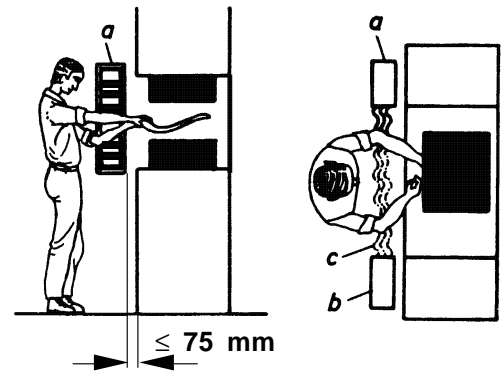

**Prevention of reaching beneath or above the light curtain**

In the normal course of events (Fig.1) the operator is seated while inserting the workpieces. To avoid the risk of reaching back into the press, the Type LSUW... infrared safety light curtain (a) is located at some distance away from the point of hazard and with a light curtain of the chosen height there is an unprotected gap. Fig.2 shows how an accident could occur through reaching over the light curtain.

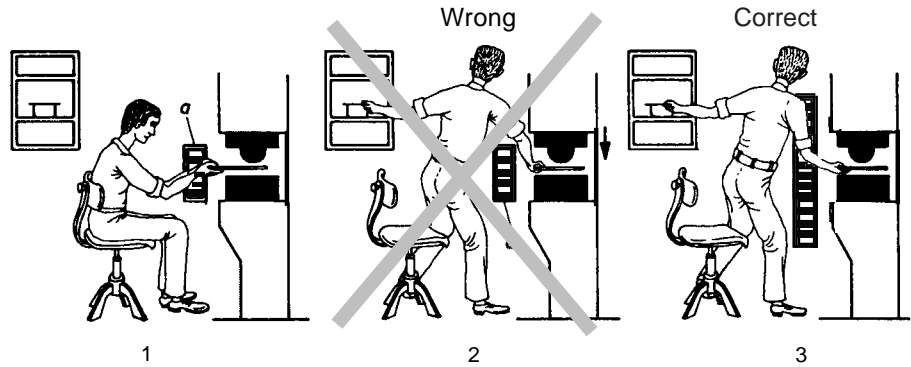
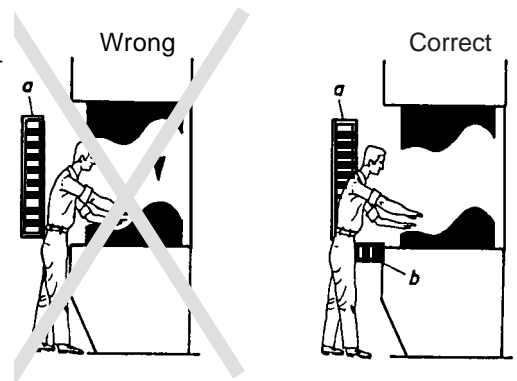

Fig.3 shows how such a risk can be avoided by fitting an infrared safety light curtain of greater height.

**Protection against standing behind the safety light curtain with operating modes A, B1, C and D (Switching unit type LSUW NSR 3-1)**

If it is necessary for technical reasons for the horizontal distance between the safety light curtain Type LSUW and the machine to be great enough for it to be possible for a person to stand between the light curtain and the point of hazard, then an additional light curtain (b) or a guard rail must be provided to make it impossible for an operator to work the machine from such a position.





**Distance from reflective surfaces**

To prevent failure to detect an obstruction as a result of reflection from some reflective object it is necessary for a Type

LSUW infra-red safety light curtain to have a minimum clearance *a* from the reflective object concerned. The minimum clearance *a* can be taken from the following table:

Protective field width in m	2,5 - 3	4	5	6	7	8	10
Distance in mm	105	140	180 </tr				

A special arrangement of the lens shielding system results in it being possible to mount a Type LSUW safety light curtain above a reflective surface without the light beam being diverted, and thus to avoid the possibility of the system failing to detect an obstruction as a result of reflection.

Type LSUW safety light curtains can optionally be supplied with flat aluminium covers for applications where it is required to mount the transmitter and receiver directly on a work table. With such an arrangement, the protective field begins close above the reflective surface.

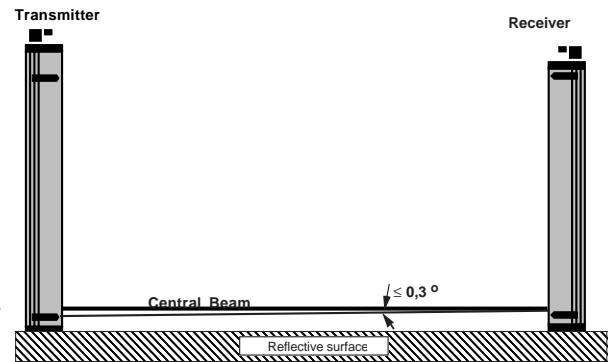
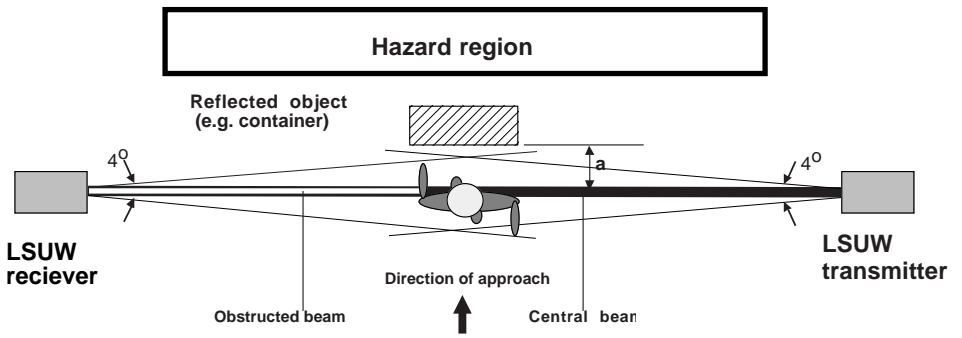

**Arrangement of two adjacent Type LSUW... safety light curtains or safety light grids**

To avoid the possibility of two Type LSUW safety light curtains or safety light grids affecting one another, the following must be observed:

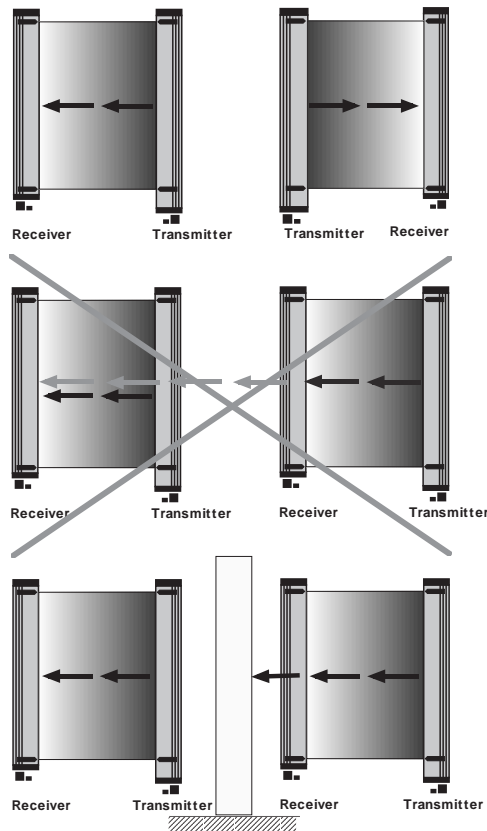

**Mounting the transmitter and receiver**

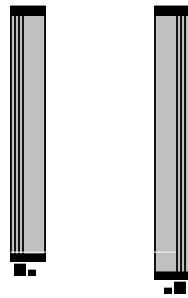

When mounting the transmitter and receiver it should be remembered that the transmitter is about 30 mm longer than the receiver because of the so-called line projector with which it is fitted. The reference edge for alignment of the two units is thus top edge of each unit, not the ends with the connector plugs.

**Fastening straps**

The fastening straps that are supplied with the units serve for securing and adjusting the light curtain. The straps, in conjunction with the tenon blocks, provide a universal means of mounting.

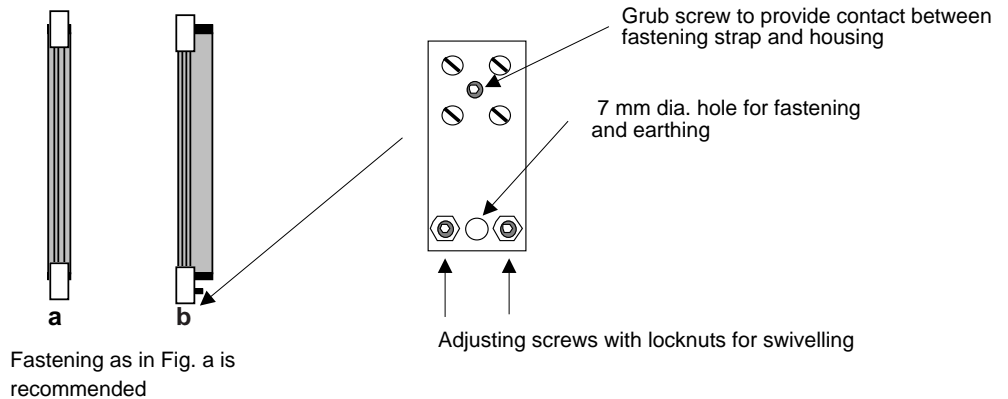

Fastening as in Fig. a is recommended

**Anti-vibration mounts**

Where there is heavy vibration, it is recommended to use the anti-vibration mounts that are optionally available.



**Important**

To ensure trouble-free operation, both the transmitter and receiver units should be mounted on stable, distortion-free, structures that are parallel to one another. The straps should be so fitted that the adjustment screws remain accessible. Care should be taken to avoid distorting the bodies of the transmitter and receiver units as that would make it impossible to achieve proper optical adjustment (avoid making an adjustment to the screw on one side without the screw on the other side being loosened).

#### Wall mounting

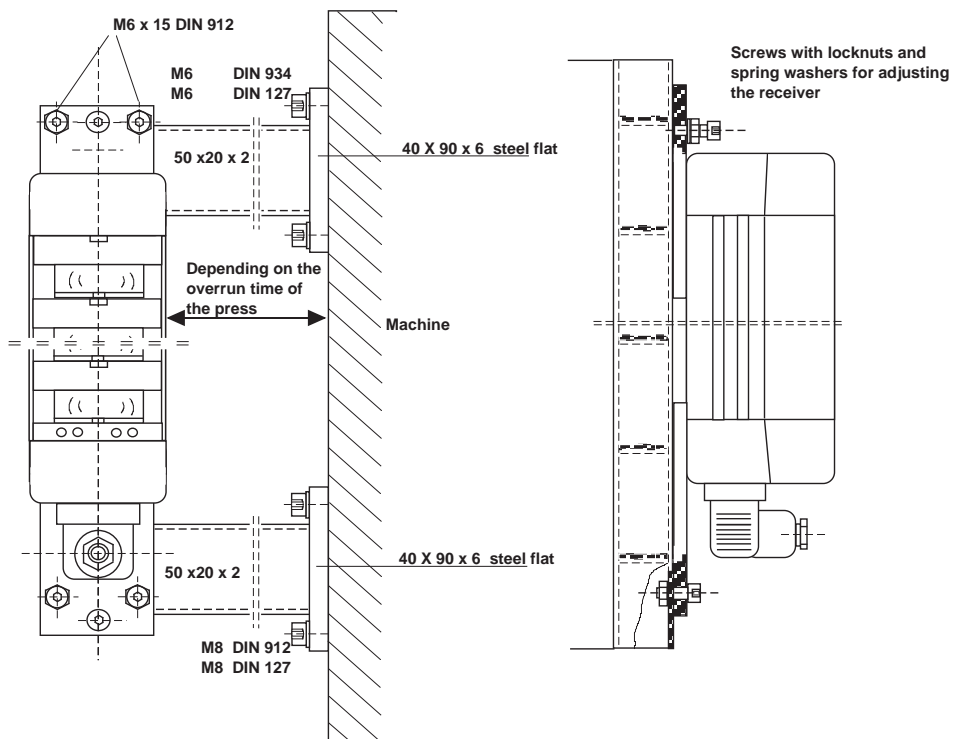

**Column mounting** When requested, Type LSUW light barriers and mirrors can be supplied ready mounted on support columns.

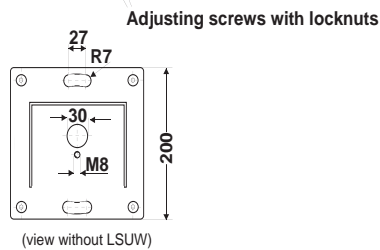
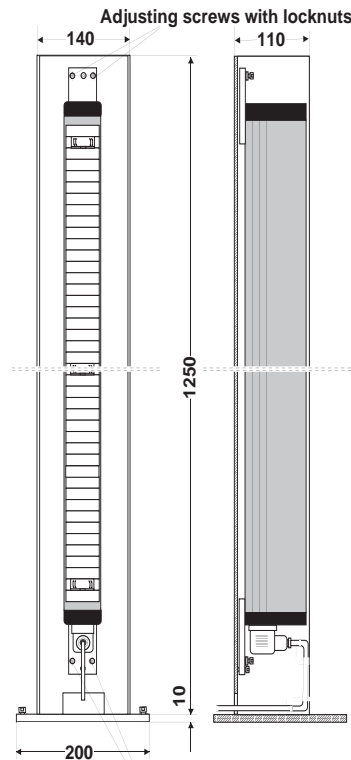

Column with light barrier LSUW

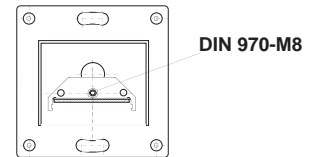
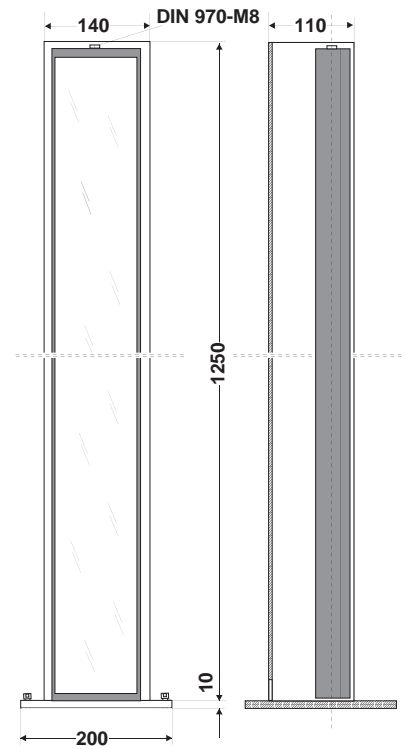

Column with mirror

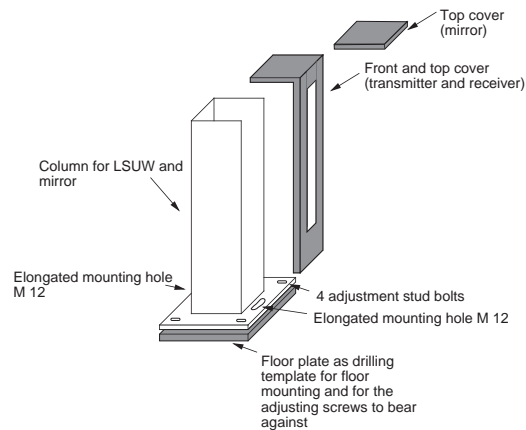

**Screening on more than one side** The use of beam diversion mirrors makes it possible to provide screening around a point of hazard.

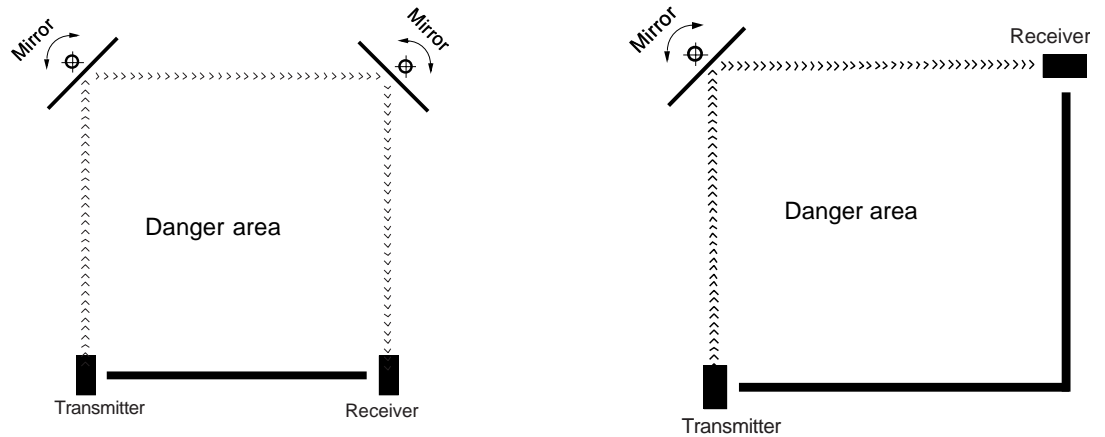

With such an arrangement the optical reflection law, angle of incidence equals angle of reflection, applies. Thus to achieve a 90° beam diversion, the mirrors need to be set at an angle of 45°. Type LSUW diversion mirrors are swivel mounted to allow for adjustment.

**Reflection losses** Each time the beam is diverted by a mirror the transmitter signal is weakened and so it is important when ordering to state the distance between the transmitter and receiver and how many times the beam is to be diverted. It is essential for the transmitter, receiver and mirrors to be mounted absolutely vertical and for this to be checked with bubble levels.

**Mounting** For such a system to work reliably it is important that the mirrors be mounted with adequate stability.



**Detailed mounting instructions are given in Chapter 8.**

With the aid of the black floor plates supplied with the mirrors, M12 holes can be bored in the floor to provide for

**Mounting of transmitter, receiver, and mirror columns**

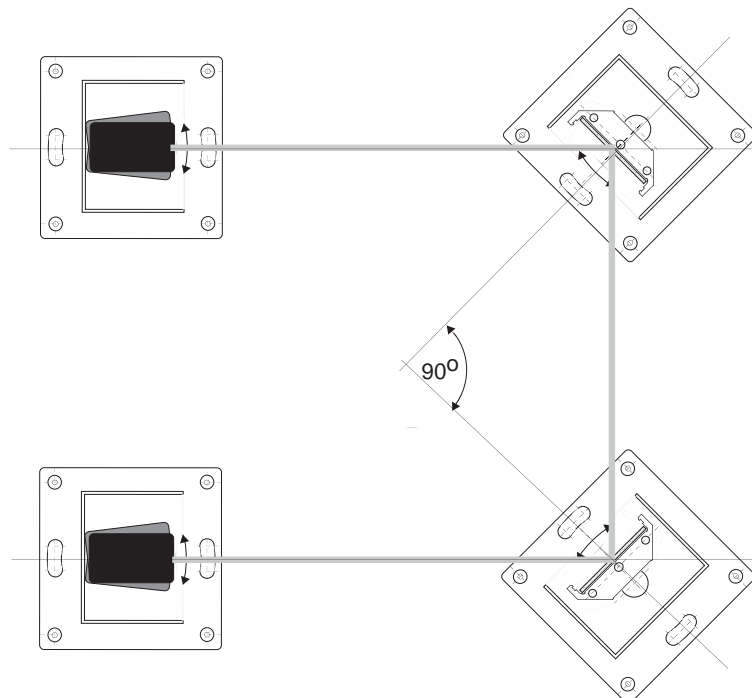

securing the columns as shown in the adjacent drawing. The transmitter, receiver, and mirror columns have to be set vertically at exactly the same height. This makes it essential to use a precision bubble level. Each of the columns is provided with four adjusting screws to facilitate setting the columns exactly vertical. The mounting holes are elongated to allow for turning the columns and the mirrors can also be turned after loosening the M8 hexagon nuts on the tie rods that are to be found beneath the top cover. Fine adjustment is effected as described in Chapter 8 after first remo-

ving the front and side covers. After mounting and adjustment is completed, the front covers must be fitted back.

### Electrical data

**Means of connection** Switching unit: Plug base with screw terminals 3x0.75mm<sup>2</sup> 230V/60VA, Transmitter/Receiver: 3-/4-pole DIN 43650 plug and socket connector.

**Mains voltage** 24V DC, -15%, +10% / 30 VA

**Power consumption** Max. 0.09 Amp.

**Protection against incorrect connection** Protection is not provided against all possibilities of incorrect connection.

**Switching function** 2 floating, monitored, positive-action, normally-open contacts. In the case of LSUW NSR 3-1 an additional non-monitored, floating normally-closed auxiliary contact.

**Switching voltage** 250 V AC.

**Load current** Max. 2 A non-inductive.

**Load capacitance** Non-inductive. In the event of an inductive load a spark-quench element must be connected parallel to the load (e.g. 0.22 µF, 220 Ω).

**Short-circuit strength** Positive-action contacts protected by 3.15 Amp semi-delayed-action fuse.

**Response time** LSUW NSR 3-1: 30 ms from interruption of the protective field to opening of the output contacts.  
 LSUW N1: 20 ms from interruption of the protective field to opening of the output contacts.  
 LSUW N1 DUO: 20 ms from interruption of the protective field to opening of the output contacts.  
 LSUW N1 K: 20 ms from interruption of the protective field to opening of the output contacts.  
 LSUW N1 Muting: 25 ms from interruption of the protective field to opening of the output contacts.

**Connecting cable** 0,75 mm<sup>2</sup> cross section.

**Cable insulation** The cables connecting all the devices concerned must have insulation suitable for the rated voltage of 250 V.

**Cable arrangement** Cables to be laid separate from high-voltage cables.  
 In the case of LSUW NSR 3-1 the maximum length of cable to terminals 4, 5, 8 and 9 must not exceed 1 meter-  
 The cables leading to the contactor monitor must be so arranged that there is no possibility of the conductors short circuiting. (In the case of LSUW NSR 3-1 no short circuit between the conductors leading from terminals 6 and 7 to the control contacts. In the case of all other switching units, no short circuit between the conductors leading from the start pushbutton and terminal 22 to the control contacts.)



**Connection of other equipment** prEN 50100 forbids the connection of other equipment to the direct-current output of the switching unit

### Ambient conditions of the switching units

**Ambient temperature during operation** -10 to +55 °C

**Ambient temperature during storage and transport** - 25 bis 70 °C

**Protection/Enclosure** IP 40, optional IP 55 (wall-mounting housing)

**Humidity class** E

**Protection class** Double insulated

### Important note



Only once the safety light curtain has been connected in accordance with one of the circuit diagrams detailed below, and if all national and international safety regulations are complied with can accident-free operation be ensured  
 Any modification of the specified circuit could result in a hazardous situation and so is forbidden.

**PLC triggering** If the switching unit is used to trigger a programmable logic control (PLC) one output channel must be arranged to effect an immediate stop of the hazardous movement beyond the PLC unless the PLC concerned is considered self monitoring equipment within the meaning of the accident-prevention regulations.

**Connection diagramm**

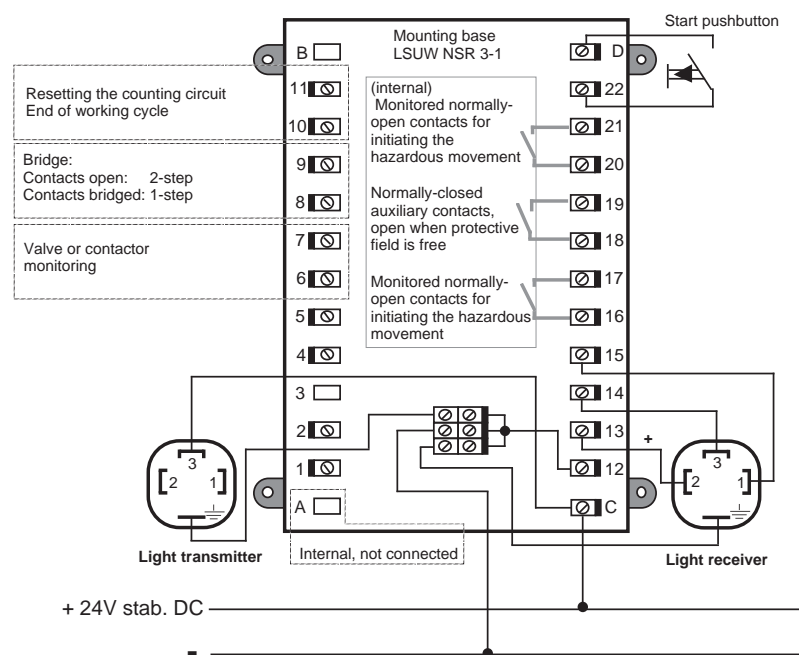

The required clearance from the point of hazard and the minimum obstruction size is stated on the type plate (see also Chapter 4.1).

The working-current supply that initiates the hazardous movement is connected by way of terminals 16 - 17 and 20 - 21.

Switching function: Two normally-open, floating, monitored, forced-opening, contacts.

The output contacts are floating contacts whose loading must not exceed 2 A/250 V AC or 60 V DC, 30 W.

In the event of an inductive load, a spark-quench element (e.g. 0.22 µF, 220 Ω) must be connected parallel to the load (not to the contacts)

No external potential must be applied to terminals 4, 5, 6, 7, 8, 9, 10, 11, D and 22.

To increase the certainty of switching, double contacts should be used for interruption of the hazardous movement.

The hazardous movement of the working machine must only be switched by way of the working-current path, terminals 16 - 17 and 20 - 21.

The output 18 - 19 serves as a monitoring path. It must not be used as a contact to initiate the hazardous press-closing movement

When any electrical welding work is to be done on the machine, the switching unit should be disconnected and the plug connecting the light receiver be withdrawn as, otherwise, stray welding current could destroy the electronic components these devices contain.

**Function** Protective and control operation with cyclic entry into the safety area (1-stroke or 2-stroke operation)

**Application** Cyclic operation with 30 second delay monitoring for the control of presses with a table height exceeding 750 mm for manually inserted workpieces.

**Example** The press makes a working stroke after the operator has reached once or twice (programmable) into the protective field while the press is stopped at its upper dead point. If the operator reaches into the protective field during the hazardous closing movement, the press reverses immediately and returns to its upper dead point. Renewed operation is then only possible after pressing the "Start" pushbutton and testing the light barrier by reaching once or twice into the protective field.



**Operating mode A must not be used if it is possible for a person to stand between the safety light curtain and the press (see Chapter 6.2)**

Connection diagram



#### How the system works

After switching on the press, the system must be tested by reaching into the protective field. After pressing the "Start" pushbutton while the protective field is free and then reaching once or twice into the protective field and then withdrawing, the current circuit 16-17 must close. The monitoring circuit 6-7 effects an additional check of the state of the hydraulic valves or contactors that initiate the hazardous movement. The initiation of a new working stroke or movement is only possible if reaching into the protective field resulted in both contactors or valves Kc1 and Kc2 dropping out and if the protective field is free again.

In cases where the closing movement of the press is initiated by contactors Kc1 and Kc2 the normally-open contacts of Kc1 and Kc2 are to be connected in series.

The output 18 - 19 serves as a monitoring path. It must not be used as a contact to initiate the hazardous press-closing movement.

If there is a delay of 30 seconds before the next

occasion of reaching into or clearing the protective field, the process monitoring feature prevents restarting of the press.

Resetting of the stroke counting circuit is effected by briefly interrupting the connection between terminals 10 - 11 (approx. 20 ms) by means of a switch on the machine.

The "Start pushbutton" connection (Terminals D - 22), the normally-closed Kc1 and Kc2 monitoring contacts (Terminal 6 - 7) and the contacts for "resetting the counter circuit" (Terminals 10 - 11) are for switching low voltages at low current rates. The contacts must be considered as floating contacts and be dimensioned accordingly (preferably twin contacts).

It is required by prEN 50100 that on switching from one operating mode to another, the restart interlock must be activated. This requirement can be met by switching off the transmitter during the changeover.



**Function** Protective and control operation with restart interlock during the entire cycle

**Application** For applications where cyclic reaching into the protective field is required. See, for example, ZH 1/281 and ZH 1/597.

**Example** Presses with a table height of less than 750 mm without additional protective devices, with which there is no control system and high-speed automatic punching machines where cyclic testing is not necessary.

### Connection diagram

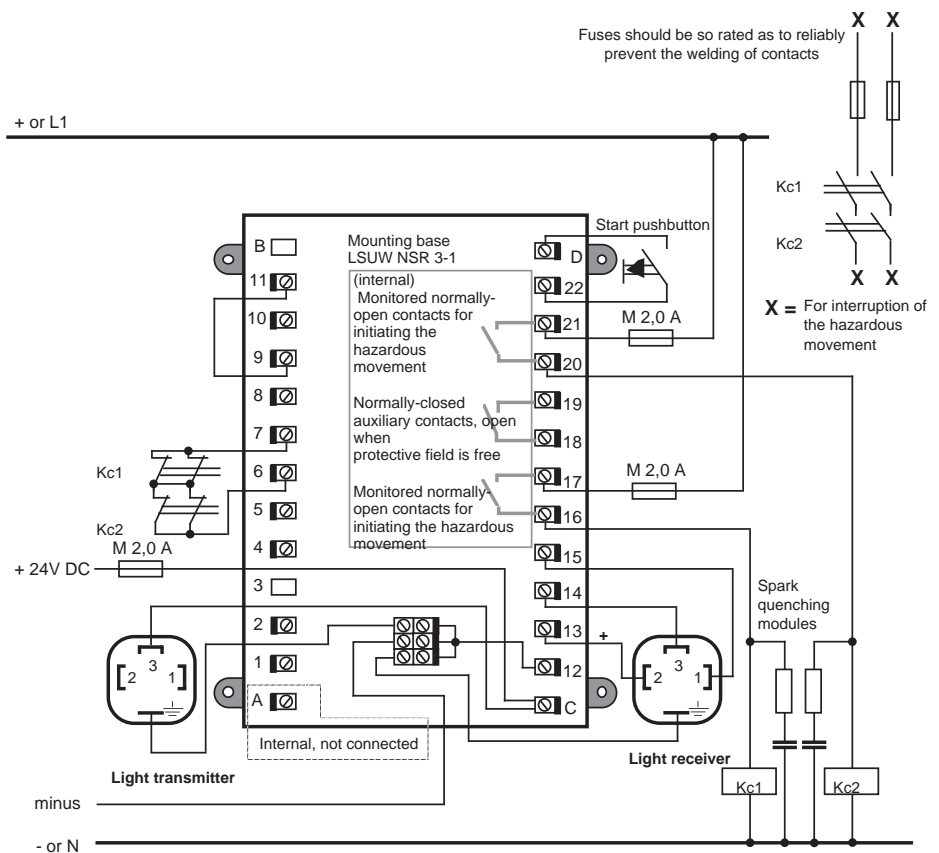

### How the system works

After switching on the machine concerned, the system must be tested by reaching into the protective field. When the "Start" pushbutton is pressed, so long as the protective field is free, current paths 16 - 17 and 20 - 21 must close.

If anyone reaches into the protective field, the machine stops immediately and can only be restarted after the "Start" pushbutton has been pressed once again.

The monitoring circuit 6-7 effects an additional check of the state of the hydraulic valves or contactors that initiate the hazardous movement. The initiation of a new working stroke or movement is only possible if reaching into the protective field resulted in both contactors or valves Kc1 and Kc2 dropping out and if the protective field is free again.

In cases where the closing movement of the press is initiated by contactors Kc1 and Kc2 the normally-open contacts of Kc1 and Kc2 are to be connected in series.

The output 18 - 19 serves as a monitoring path. It must not be used as a contact to initiate the hazardous press-closing movement.

The "Start pushbutton" connection (Terminals D - 22), the normally-closed Kc1 and Kc2 monitoring contacts (Terminals 6 - 7) and the contacts for "resetting the counter circuit" (Terminals 10 - 11) are for switching low voltages at low current rates. The contacts must be considered as floating contacts and be dimensioned accordingly (preferably twin contacts).

The "Start" pushbutton must be fitted in a position from which the hazard area can be clearly seen but that is such that the pushbutton cannot be actuated from the hazard area without interrupting the light barrier.

**Function** Protective and control operation with restart interlock during the process movement



**Operating mode B1 must not be used if it is possible for a person to stand between the safety light curtain and the machine (see Chapter 6.2)**

**Connection diagram**

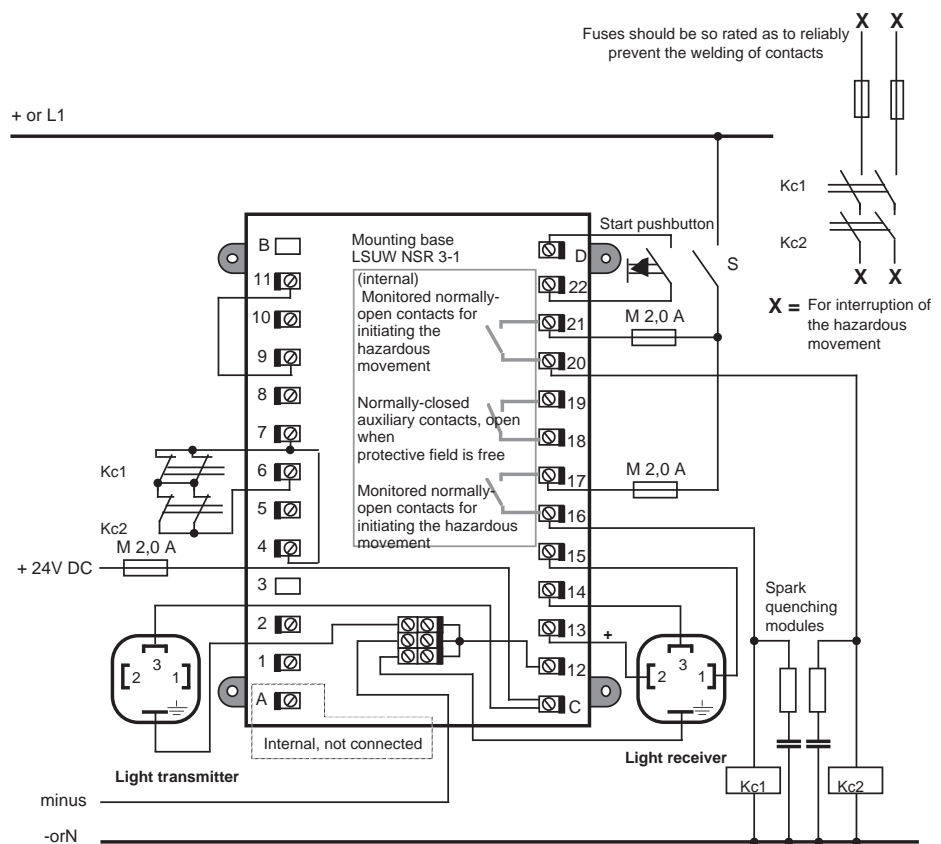

**How the system works**

If anyone should reach into the protective field while the machine is making the hazardous movement, the movement is stopped immediately and restarting is only possible after the "Start" pushbutton has been pressed once again.

When the machine is at rest (Switch "S" open), there is free access to the machine without it then being necessary to press the "Start" pushbutton before restarting is possible.

After switching on the machine concerned, the system must be tested by reaching into the protective field. After pressing the "Start" pushbutton, so long as the protective field is free, the current paths 16 - 17 and 20 - 21 close. The monitoring circuit 6-7 effects an additional check of the state of the hydraulic valves or contactors that initiate the hazardous movement.

The initiation of a new working stroke or movement is only possible if reaching into the protective field resulted in both contactors or valves Kc1 and Kc2 dropping out and if the protective field is free again. In cases where the closing movement of the press is initiated by contactors Kc1 and Kc2 the normally-open contacts of Kc1 and Kc2 are to be connected in series.

The output 18 - 19 serves as a monitoring path. It must not be used as a contact to initiate the hazardous press-closing movement.

The "Start pushbutton" connection (Terminals D - 22) and the normally-closed Kc1 and Kc2 monitoring contacts (Terminals 6-7) are for switching low voltages at low current rates. The contacts must be considered as floating contacts and be dimensioned accordingly (preferably twin contacts).

**Function** Protective and control operation without restart interlock, with valve or contactor monitoring on power-driven machines. See, for example, ZH 1/597.

**Application** To provide protection in the vicinity of power driven machines or to effect a restart disable in the machine control.



**Operating mode C must not be used if it is possible for a person to stand between the safety light curtain and the machine (see Chapter 6.2).**

**Connection diagram**

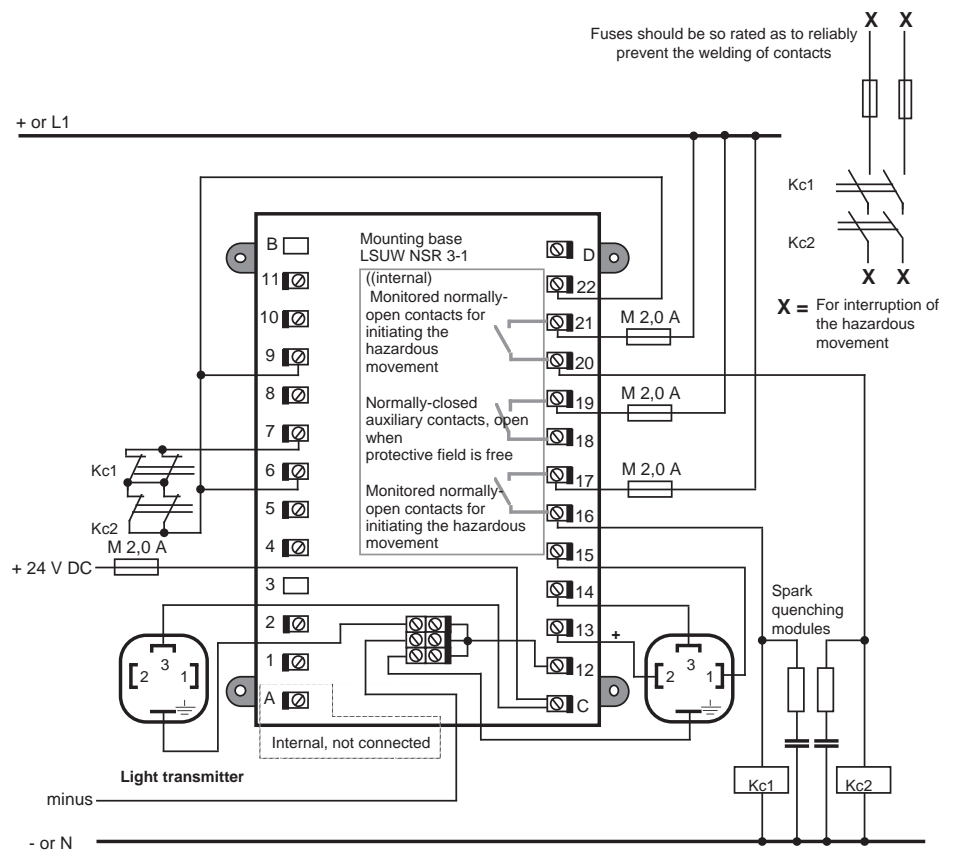

**How the system works**

After switching on the machine concerned, the system must be tested by reaching into the protective field. On withdrawal from the protective field, the contacts between Terminals 16 - 17 and 20 - 21 close while those between the output Terminals 18 - 19 are open.

The output 18 - 19 serves as a monitoring path. It must not be used as a contact to initiate the hazardous press-closing movement.

On penetration of the protective field, current paths 16 - 17 and 20 - 21 open while current path 18 - 19 closes.

The monitoring circuit 6-7 effects an additional check of the state of the hydraulic valves or contactors that initiate the hazardous movement. The switch connection, the normally-closed monitoring contacts (Terminals 6 - 7), are for switching low voltages at low current rates. The contacts must be considered as floating contacts and be dimensioned accordingly (preferably twin contacts).

**Function** Protective and control operation with restart interlock and cyclic testing

**Application** e.g. for protection at the rear of a press without cyclic reaching into the protective field. See, for example, ZH 1/281 4.6



**Operating mode D must not be used if it is possible for a person to stand between the safety light curtain and the machine (see Chapter 6.2)**

### Connection diagram

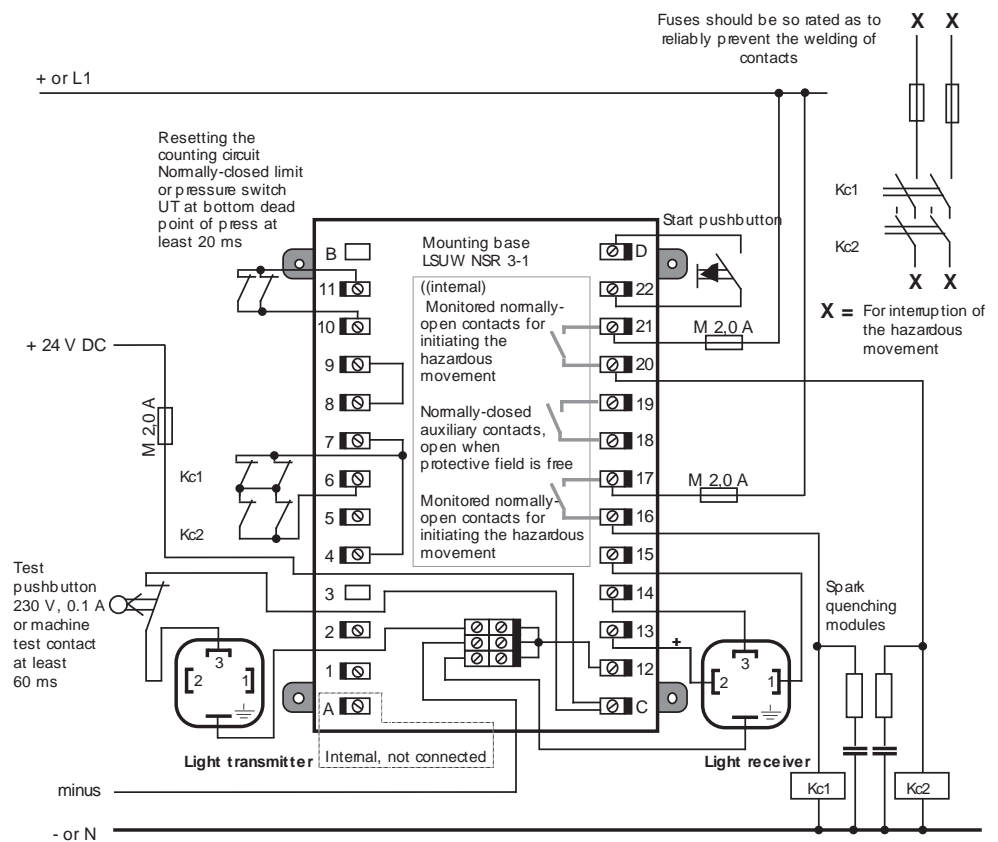

### How the system works

In the majority of applications the operator reaches once or several times into the protective field during every working cycle and thus the system is continuously tested but in automatic operation such action is unnecessary and thus the light-barrier system often remains untested for several hours.

It is, however, frequently required that the system be tested before each operating cycle and thus testing has to be initiated by the machine itself.

This is effected by a switch on the machine briefly interrupting the connection between terminals 10 - 11 (approx 20 ms) to reset the counting circuit, and to interrupt the connections between 16 - 17 and 20 - 21. A wipe pulse of at least 60 ms causes the power supply to the light transmitter to be interrupted.

After switching on the machine concerned, the system must be tested by reaching into the protective field. On pressing the "Start" pushbutton while the protective field is free and then effecting a single penetration of the protective field and then withdrawing, the contacts between output terminals

16 - 17 and 20 - 21 must close.

The monitoring circuit 6-7 effects an additional check of the state of the hydraulic valves or contactors that initiate the hazardous movement. The initiation of a new working stroke or movement is only possible if reaching into the protective field resulted in both contactors or valves Kc1 and Kc2 dropping out and if the protective field is free again.

The output 18 - 19 serves as a monitoring path. It must not be used as a contact to initiate the hazardous press-closing movement.

The "Start pushbutton" connection (Terminals D - 22), the "Counter reset circuit" contacts (Terminals 10 - 11) and the normally-closed contactor-monitoring contacts (Terminals 6-7) are for switching low voltages at low current rates. The contacts must be considered as floating contacts and be dimensioned accordingly (preferably twin contacts).

- Function** Protective and control operation with start and restart interlock and valve or contactor monitoring
- Application** The protection of hazard areas that can be walked into.  
For applications requiring cyclic entry into the protective field.
- Example** Protection of the area around a robot  
Presses with table height of less than 750 mm

#### Connection diagram

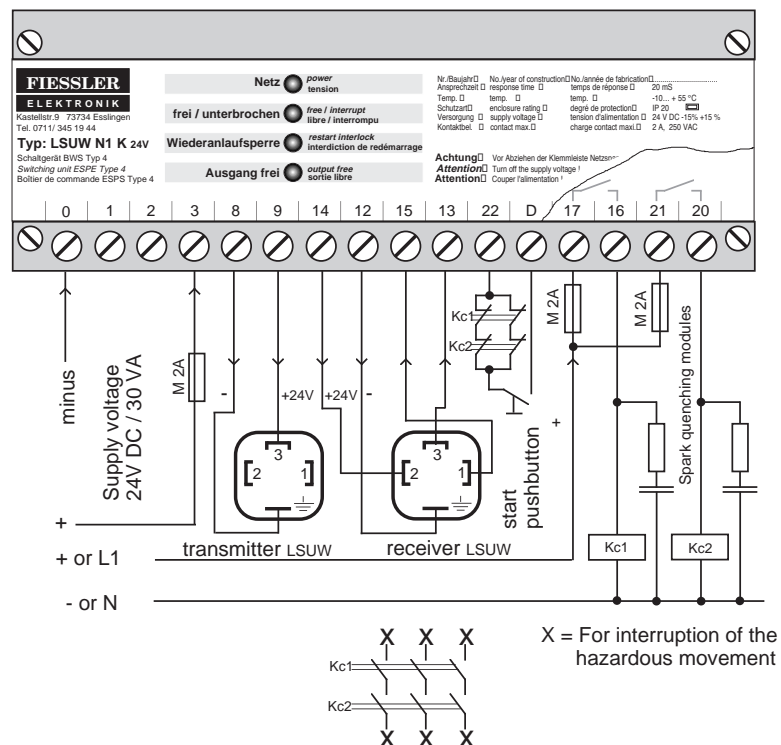

#### How the system works

The transmitter is switched on by pressing the Start pushbutton.

As a means of checking, an LED on the transmitter lights. If the protective field is free, this causes infrared light to reach the receiver and cause it to switch to "green". On the switching unit, the "free" LED lights.

On the Start pushbutton being released, contact is made between 16-17 and 20-21 and the control for the transmitter switches to self-hold. The "Output free" LED lights.

If the protective field is penetrated the contacts between 16-17 and 20-21 are opened.

Restarting is then only possible after freeing the protective field and pressing the Start pushbutton.

The normally-closed contacts Kc1 and Kc2, connected in series with the Start pushbutton, serve to monitor the state of the contactors.

#### Note:

During adjustment operations the Start pushbutton has to be kept pressed continuously or be bridged.

The "Start" pushbutton should be fitted in a position from which the hazard area can be clearly seen but is such that the pushbutton cannot be actuated from the hazard area without interrupting the light barrier.

**Application** The protection of a hazard area that is accessible from one side by means of two light barriers (1 Start pushbutton)



**Note remarks in Chapter 6.2**

**Connection diagram**

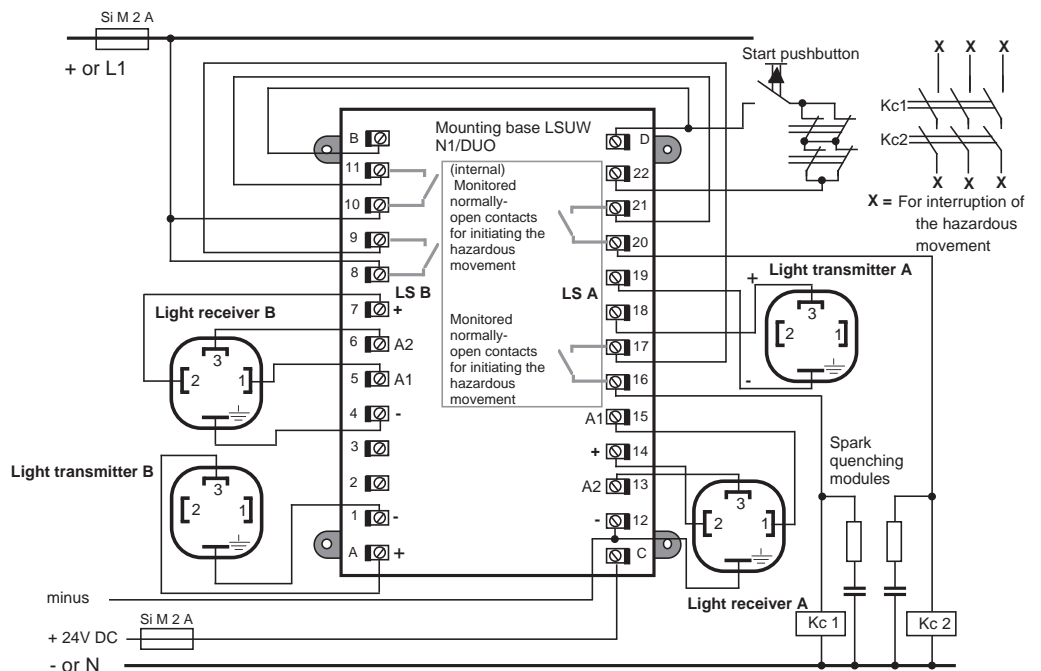

**How the system works**

Transmitters A and B are switched on by pressing the Start pushbutton.

As a means of checking, LEDs on the transmitters light. If the protective fields are free, infrared light reaches the receivers and causes them to switch to "green". On the switching unit, the "free" LEDs light.

On the Start pushbutton being released, contact is made between 16-17 and 20-21 for output "A" and between 8-9 and 10-11 for output "B" and the control for the transmitters switches to self-hold. The "Output free" LEDs light.

The outputs of the two light barriers are connected in series. Switching contacts Kc1 and Kc2 open if either or both protective fields are penetrated.

Restarting is then only possible if both protective fields are free and the Start pushbutton is pressed again.

The normally-closed contacts on contactors Kc1 and Kc2, which are connected in series with the Start pushbutton contacts, serve to monitor the functioning of the contactors.

**Note:**

During adjustment operations the Start pushbutton has to be kept pressed continuously or be bridged.

The "Start" pushbutton should be fitted in a position from which the danger area can be clearly seen but that is such that the pushbutton cannot be actuated from the hazard area without interrupting the light barrier.

#### Connection diagram for Switching unit LSUW N1 Duo 7.4

#### Protection of two independent danger areas 7.4.2

#### Application

The protection of two separate hazard areas, each independent of the other and each accessible from either of two sides (2 Start pushbuttons).



Note remarks in Chapter 6.2

#### Connection diagram

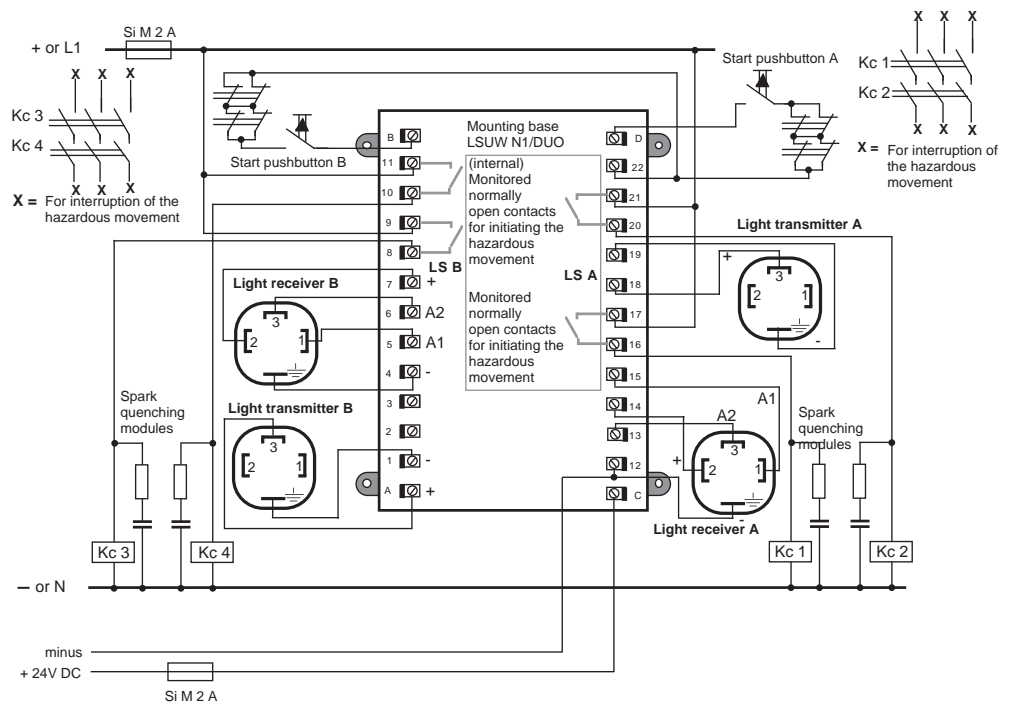

#### How the system works

Transmitters A and B are each switched on by pressing the associated A and B Start pushbutton.

As a means of checking, LEDs on the transmitters light. If the protective fields are free, infrared light reaches the receivers and causes them to switch to "green". On the switching unit, the "free" LEDs light.

On the Start pushbutton being released, contact is made between 16-17 and 20-21 for output "A" and between 8-9 and 10-11 for output "B" and the control for the transmitters switches to self-hold. The "Output free" LEDs light.

If either of the two light barriers is interrupted, the associated outputs are disconnected.

Restarting is then only possible if the protective field is free and the associated Start pushbutton has been pressed again.

The normally-closed contacts on contactors Kc1 and Kc2 and Kc3 and Kc4, each pair of which is connected in series each with the associates Start pushbutton contacts, serve to monitor the functioning of the contactors concerned.

#### Note:

During adjustment operations the Start pushbutton has to be kept pressed continuously or be bridged.

The "Start" pushbuttons associated with each light barrier should be fitted in a position from which the danger area concerned can be clearly seen but that is such that the pushbutton cannot be actuated from the hazard area without interrupting the light barrier concerned.

**Function** Possibility of briefly disabling (muting) a safety light barrier to allow for the movement of material into or out of a production cell, while clearly distinguishing between a person and a fork-lift truck.

**Application** The LSUW N1 Muting switching unit is for use wherever it is necessary to distinguish between the movement of a person and the movement of material.

**Circuit diagram**

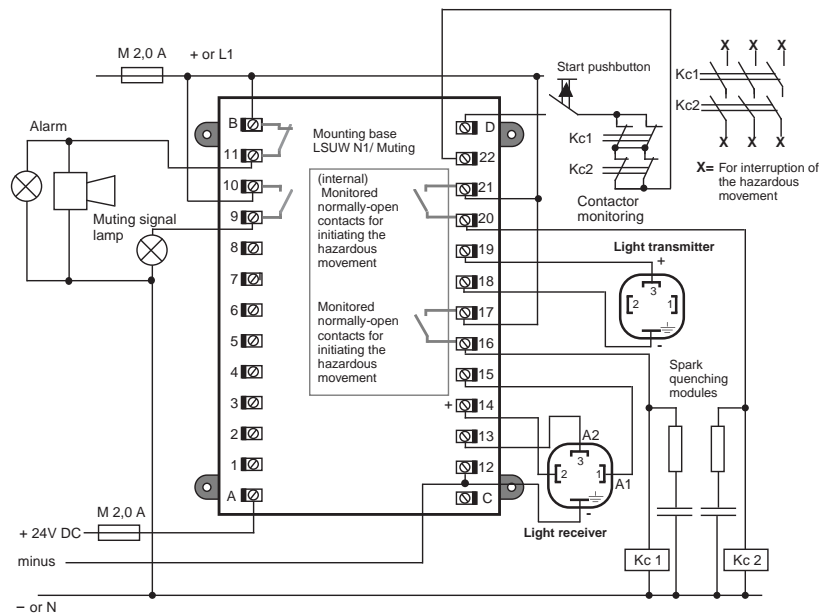

**How the system work**



When used in conjunction with an LSUW vertical safety light barrier and four muting sensors or an

LSUW horizontal safety light grid, this switching unit makes it possible to distinguish between the movement of a person and the movement of material.

The following components are needed for the muting function:

1. Switching unit LSUW N 1 Muting
2. A safety light barrier (Transmitter and receiver) e.g. LSUW 895/3
3. Four muting sensors, e.g. light barriers, inductive sensors, cam switches or dual-channel safety light grids, e.g. LSUW 1135/2
4. Muting signal lamp



To avoid the possibility of two simultaneous faults or deliberate manipulation causing the muting sensors to be out of action for any length of time, a reliable time-monitoring feature is provided to cancel the muting function after an adjustable period of 3 - 90 seconds. This period is set by Fieessler Electronic to customers' instructions. Provision is also made for switching to operation without time monitoring.

The muting lamp (max. 230 V, 60 W, min 24 V AC or DC, max. 0.5 A), that signals the muting state, is monitored. Muting is not possible if the muting lamp is not connected or is defective.

On the complete system being connected to the electricity supply the alarm is activated. It can be deactivated by means of a key-operated Start switch.

For applications where no interruption of the hazardous movement is possible and it is only necessary to sound an alarm, it is necessary for the Start switch to be in the form of a key-operated switch from which the key can only be withdrawn when the switch contacts are open.

**Before the key-operated start switch is actuated it must be ensured that no person is within the danger area. The key-operated switch must be fitted in a position from which the protected area can be readily seen.**

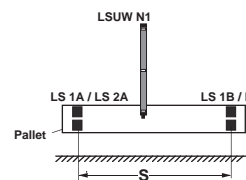

For the system to function correctly, the distance S must be less than or equal to the length of the pallet, the fork-lift truck or the reflective strip.

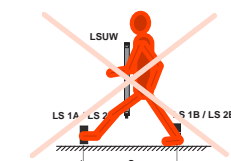

**The distance S must be great enough for it to be impossible for a human being to interrupt or actuate both the muting sensors LS1/LS2 and LS1A/LS2A simultaneously.**

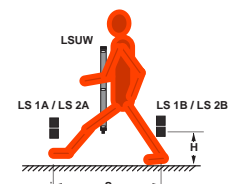

It may be necessary for the clearance H from the floor level or for the distance S to be increased.



#### Connection diagram for Switching unit LSUW N1 Muting 7.5

#### Muting function with four muting sensors and time monitoring 7.5.2

**Application** For example: protection of pallet transport systems  
 protection of a production cell  
 protection in high-bay warehouses and

#### Circuit diagram

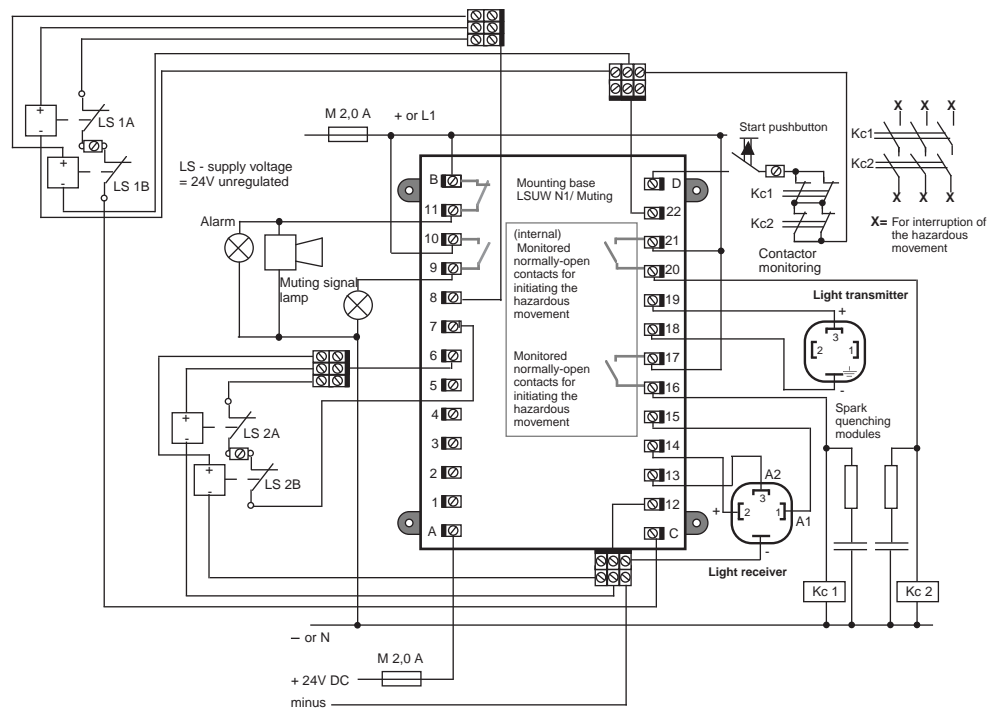

#### How the system works

Muting is effected by both the muting channels contacts LS1A/LS2 and LS1/LS2A being **open** but not for longer than the set period. While the system is in this state the safety light barrier LSUW can be penetrated without the alarm being activated or the entire plant being shut down.

The alarm is actuated or the plant shut down if the safety light barrier LSUW is interrupted at a time when it is not bridged by the muting sensors. Such an interruption of the safety light barrier is not permissible and thus contacts 20-21 and 16-17 open.



So long as the safety light barrier LSUW is free, a new start and deactivation of the alarm is possible by actuating the key-operated Start switch.

**Before the key-operated switch is actuated it must be ensured that no person is within the danger area.**

**For security reasons minus and plus currensts must be fitted as shown in the connection diagram. Cabeling for the muting channels 1 (LS1A/B) and 2 (LS2A/B) must be done seperately.**

Contacts of the muting channels LS can also be replaced by end-switches.

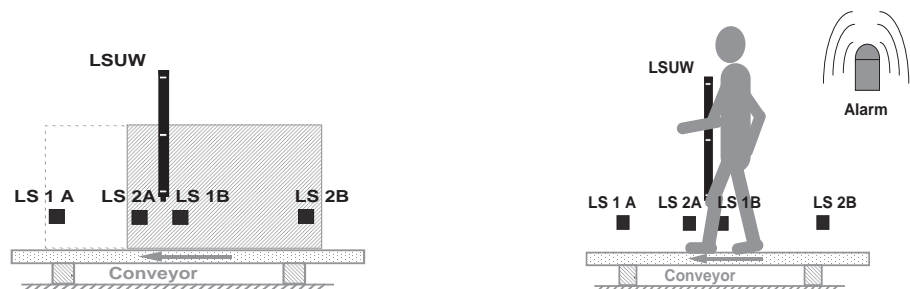

**Connection diagram for Switching unit LSUW N1 Muting** 7.5  
 Muting function with four muting sensors without time monitoring 7.5.3

**Application** For example: protection of pallet transport systems  
 Safety in high-bay warehouses where the high-bay warehouse vehicle can be parked in the entry region.

**Connection diagram**

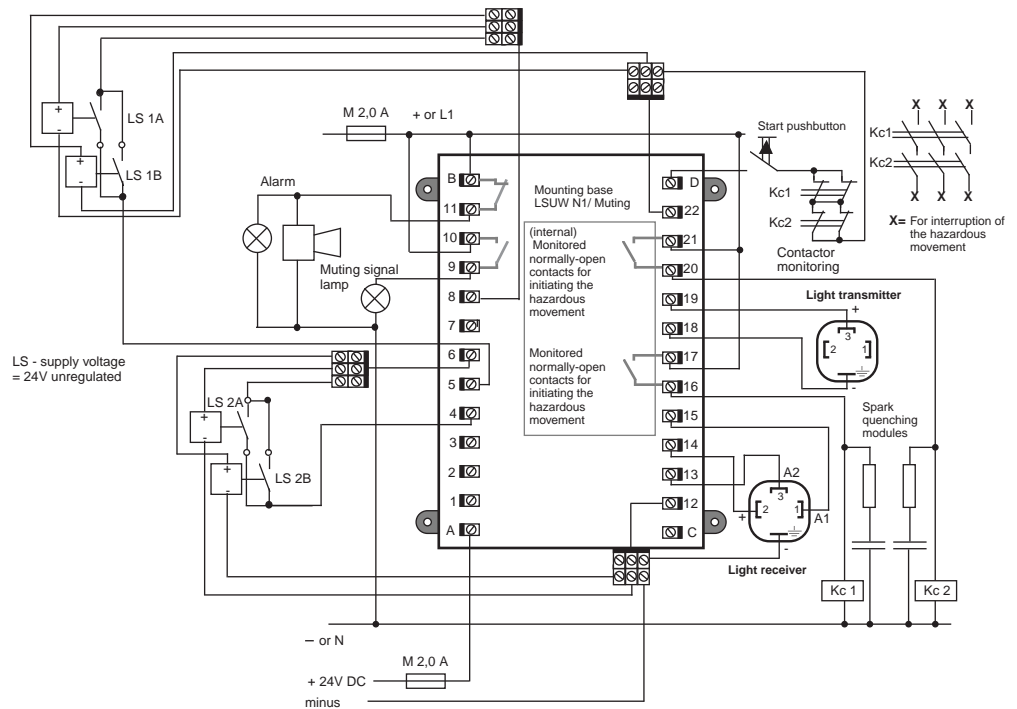

**How the system works**

Muting is effected for as long as the muting sensor contacts LS1/LS2 and LS1A/LS2A are **closed**.

While the system is in this state the safety light barrier LSUW can be penetrated without the alarm being activated or the entire plant being shut down.

The alarm is actuated or the plant shut down if the safety light barrier LSUW is interrupted at a time when it is not bridged by the muting sensors. Such an interruption of the safety light barrier is not permissible and thus contacts 20-21 and 16-17 open.



So long as the safety light barrier LSUW is free, a new start and deactivation of the alarm is possible by actuating the key-operated Start switch.

**Before the key-operated switch is actuated it must be ensured that no person is within the danger area.**

**For security reasons minus and plus currents must be fitted as shown in the connection diagram. Cabling for the muting channels 1 (LS1A/B) and 2 (LS2A/B) must be done separately.**

Contacts of the muting channels LS can also be replaced by end-switches.

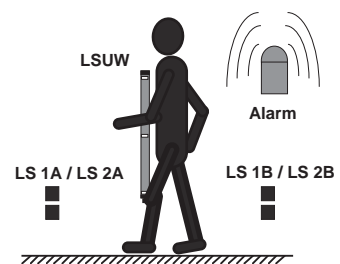
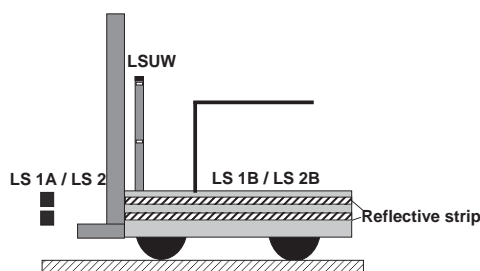

**Line projector** An alignment aid in the form of a light projector has been developed to facilitate correct alignment of Type LSUW safety light barriers with GaAs light transmitters, particularly where appreciable widths are involved. The projector, which comprises a low-voltage incandescent lamp with a straight filament and a lens, projects a white line on the receiver unit opposite to it. The line projector, that is fitted at the connector end of the GaAs light transmitter unit, can be switched on by pressing the button adjacent to the connector socket.

**Alignment** To make the line projected by the line projector better visible, alignment is best effected with the surroundings darkened so far as possible. After loosening the adjustment screws on the light transmitter, one switches on the projector and then turns the transmitter around its longitudinal axis until the white line is projected against the light receiver. If there is no obstruction between the transmitter and receiver the latter should now be "free" and its green LED should light. If this is not the case, then the receiver will need to be tilted a little around its lateral axis.

**Adjustment with mirrors** Switch on the line projector and turn the projector to direct the beam against the centre of the mirror, then adjust the mirror to direct the beam exactly against the centre of the next mirror or of the receiver

**Adjustment aid - Laser** A laser is offered as an adjustment aid for the exact adjustment of Type LSUW light barriers, particularly where there is a considerable distance between the transmitter and the receiver, or where mirrors are involved. The equipment is fitted on the front faces of the transmitter and receiver. When the pushbutton is pressed a red spot of light is projected that is visible even over a considerable distance. The red spot must be brought to appear exactly in the centre of the device fitted on the receiver. The operation has then to be repeated at the opposite end of the transmitter and receiver and any necessary readjustment is then effected.



**Adjustment aid - LEDs** To indicate the state of adjustment, two small red LEDs are provided beyond both the first and the last lens of the receiver. These cease to light as soon as there is sufficient light reserve

<b>Light barrier free, adjustment correct</b>	Large LED green Small LED not lit	Adjustment OK
<b>Light barrier free, insufficient reserve</b>	Large LED green Small LED red	Turn around longitudinal axis
<b>Light barrier free, reserve uneven</b>	Large LED green Upper or lower LED red	Turn around lateral axis

**Take care not to distort the bodies of the transmitter and receiver during adjustment**

**Test rod** As a final check one passes a rod with a diameter of 3-4 mm past the front face of the light receiver from one end to the other, so that each lens in turn is partly covered by the test rod. At no position during this operation should the green LED cease to light. This indicates the amount of reserve there is against failure resulting from dirtying of the lenses or mains voltage fluctuations.

To check the effectiveness of the safety light curtain, the test rod for the equipment concerned must be passed from one end to the other of the protective field on the transmitter side, so that the light field is only obstructed on that side. As the rod is passed from one end to the other, the "free" LED must never light. The diameter of the test rod must be equal to the minimum obstruction size indicated on the Type plate of the light curtain concerned.



**Important** The actual width of the protective field between the transmitter and receiver must be in accordance with that indicated on the Type plate of the light curtain concerned. Only then can the indicated minimum obstruction size be guaranteed.

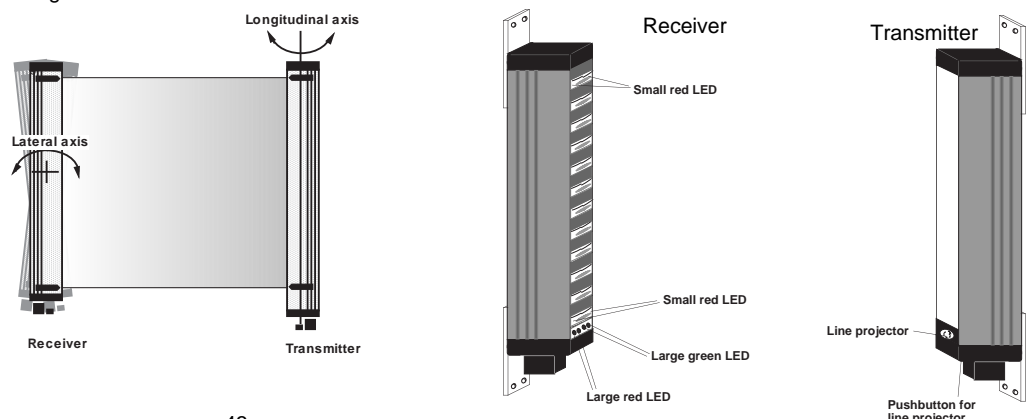

**Trouble shooting** The information below is given on the assumption that the light curtain is correctly adjusted (see Page 44)

Fault	Remedy
Switching unit outputs do not provide continuity. Large red LED and the red LED on the receiver light	Transmitter defective, send back to Fiesler
Switching unit outputs do not provide continuity. The LED on the receiver and the associated LED on the switching unit do not both light or go out together	Check the cable connecting the receiver to the switching unit. If the connections are in order the receiver is defective, send back to Fiesler
Light barrier functions correctly but the switching unit outputs do not provide continuity.	The outputs are protected by an internal 3.15 A fuse. Overload has probably caused this fuse to blow. Return switch unit to Fiesler for checking
Light barrier functioned correctly for some time but now the switching unit outputs do not always provide continuity.	Check whether a spark-quench element is connected parallel to the load. If this is not the case, the relay contacts may have burned. Return switch unit to Fiesler for checking.
The entry restriction cannot be reset by pressing the Start pushbutton. The yellow LED lights.	a. Check whether the Start switch switches. b. Check whether there is continuity through the monitor circuit for the disconnecting contacts.
On connection of the receiver to the switching unit LSUW N1 or LSUW N1 DUO or LSUW N1 Muting and then obstructing and then freeing the light barrier, the green LED lights without the Start pushbutton having been pressed.	Transmitter is not connected or is wrongly connected. Refer to circuit diagram in the base of the switching unit.
The light barrier will not switch to "free" the LEDs do not light and extinguish as they should.	Clean light barrier windows. Check alignment. Check whether the protective field width is in accordance with that stated on the Type plate.
The switching on of some heavy consumer such as a large motor acts as an obstruction of the light barrier. The red LEDs light briefly.	It is probable that the cable connecting the receiver to the switching unit is laid parallel to the power supply cables. Lay the connecting cable separately. Fit the switching unit as near as possible to the receiver.



**Please note** For applications where there is high humidity, the transmitter and receiver should have IP 65 protection and the connection ends should be at the bottom.  
Solvents can cause damage to acrylic resin windows. Light barriers with silica glass windows are optionally available.  
Welding spatter can burn into the windows. This can be prevented by fitting a replaceable glass-clear PVC protective cover.



**Maintenance instructions** Type LSUW... light barrier systems are designed to need no maintenance. It is only necessary to clean the windows in front of the light transmitter and receiver at regular intervals with a solvent-free cleaning fluid. Doing so does not, however, release one from the need for the prescribed annual inspection required by EN 50100, ZH 1/281 and ZH 1/597.



# Delivery Program:

Fiessler Elektronik  
 Kastellstr. 9 D-73734 Esslingen  
 Telefon: 0711 / 91 96 97 - 0  
 Telefax: 0711 / 91 96 97 - 50

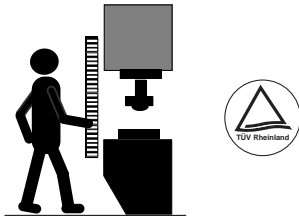

Safety-Light-Curtain

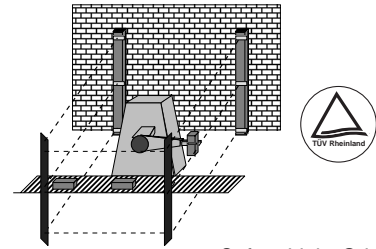

Safety-Light-Grid

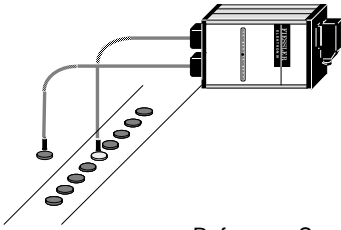

Reference-Sensor

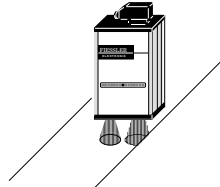

Edge-Sensor

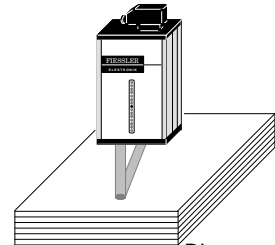

Distance-Sensor

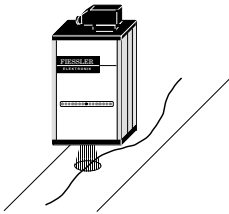

Line-Sensor

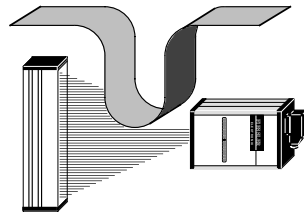

Analogue Loop-Detector

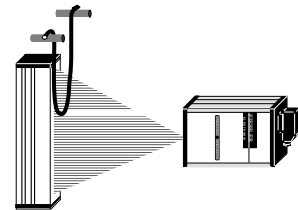

Loop-Detector For Tubes

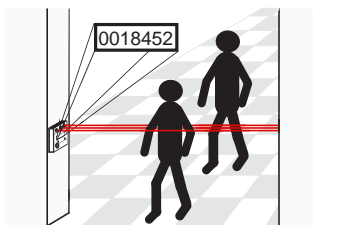

Photoelectric Controls For Counting Applications

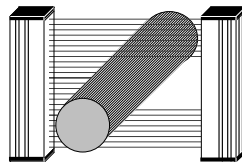

Switching And Analogue Light-Curtain

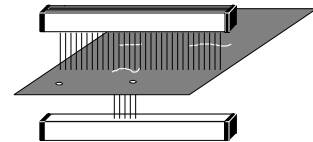

Hole -Detector

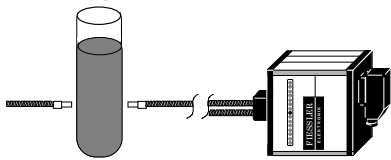

Cloudiness-Detector

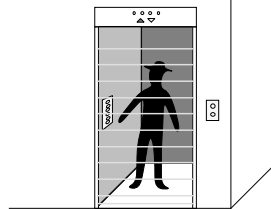

Lift Safety-Light-Curtain

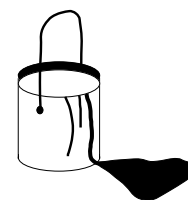

Colour-Sensor

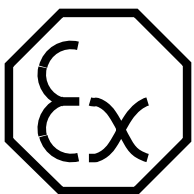

EX-Light-Barrier

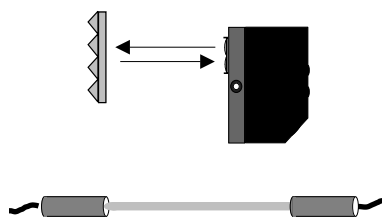

Light-Barrier For General Applications



Your Application