

### Safety Relais STM STK 41-322 RLU for Safety-contact-mat STM

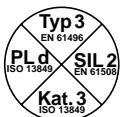
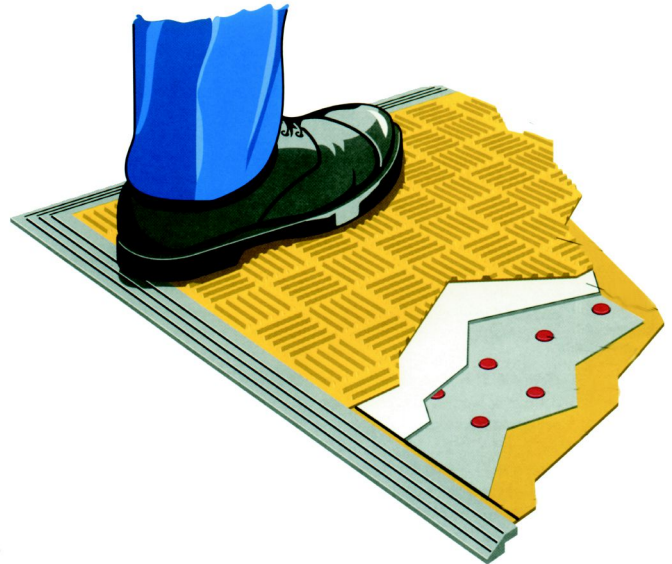
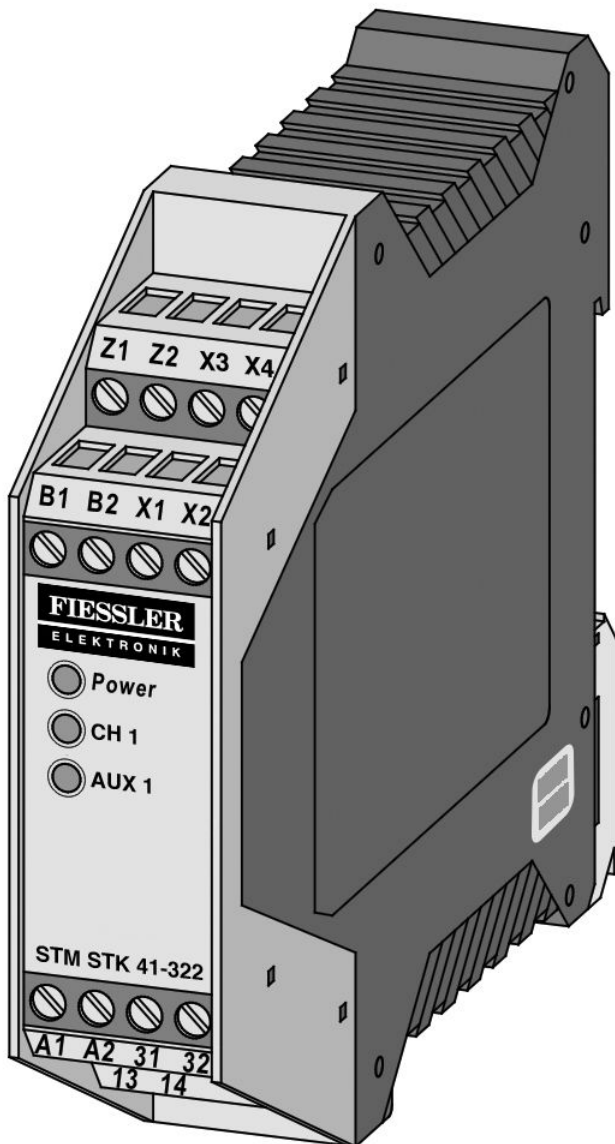

Performance Level PL d

Safety Category Type 3

Automatic reset / Manual reset

Very short reaction times

Connection of several signal transmitters



1.

**Table of Contents**

1. Table of Contents	2
2. General safety regulations and protection measures	3
3. General and function description .....	4
4. Intended use .....	5
5. Application example .....	5
6. Device overview .....	6
6.1 Versions .....	6
6.2 Signal indicators.....	6
6.3 Connection terminals .....	6
6.4 DIP switch for configuring the operating mode .....	7
7. Operating modes.....	7
7.1 Safety output.....	7
7.2 Automatic reset .....	7
7.3 Fault self-retaining – manual reset.....	7
7.4 Signaling output without any delay (RLU).....	7
7.5 Signaling output delayed (RL).....	7
8. Mechanical mounting .....	8
9. Electrical connection .....	8
9.1 Supply voltage .....	8
9.2 Connection of sensor .....	8
9.3 Connection of multiple sensors per sensor circuit	8
9.4 Connection of control circuits.....	9
9.5 Connection Reset .....	9
9.6 Connection of signaling contact .....	9
10. Commissioning and function testing.....	10
11. Fault diagnosis .....	10
12. Decommissioning and disposal .....	10
13. Technical data .....	11

All rights reserved to implement technical and operationally relevant changes of the products and devices shown in this documentation at any time without prior notice.

2.

### **General safety regulations and protection measures**

The manufacturer and user of the system/machine on which the protection system is used are responsible for coordinating and adhering to all applicable safety rules and regulations under their own responsibility.

The protection system guarantees functional safety in combination with the superordinate control system, but not the safety of the entire system/machine. Thus, a safety review of the entire system/ machine in accordance with machine directive 2006/42/EC or relevant product standards is necessary prior to use of the device.

The operating instructions must be permanently available at the operating location of the protection device. They must be thoroughly read and applied by every person who is tasked with the operation, maintenance or repair of the protection device.

The installation and start-up of the protection device may only be conducted by specialized personnel who are familiar with these operating instructions and the applicable regulations on job safety and accident prevention. The instructions in these operating instructions must be followed and adhered to unconditionally.

Electrical work may only be carried out by skilled electricians. Safety regulations for electrical engineering and from the professional association must be followed.

In case work has to be carried out on the switching device, it must be switched to a voltage-free position and checked for freedom from any voltage and secured against being switched back on again.

If the potential-free connections of the safety switching contacts are supplied with a hazardous voltage from an external source, it must be ensured that these are also switched off when working on the switching device.

The switching device does not contain any components that the user must service. Any warranty or liability on the part of the manufacturer is forfeited in the event of any unauthorized modifications or repairs to the switching device.

Auxiliary outputs must not execute any safety-orientated functions. They are not fail-safe and are not checked either by testing.

The system must be checked for correct function in suitable intervals by qualified persons for the standard-conform design of the safety system. The check must be documented in a way that allows it to be traced at any time.

**In the case of non-compliance or deliberate abuse, the manufacturer's liability will cease.**

3.

#### General and function description

The STK 41-322 switching device is used to evaluate sensors such as safety contact mats, safety contact edges and safety bumpers for securing crush and shear locations.

An Finessler sensor can be connected to the switching device. The steady-state current monitoring of the sensor is made possible by an integrated terminating resistor in the sensor.

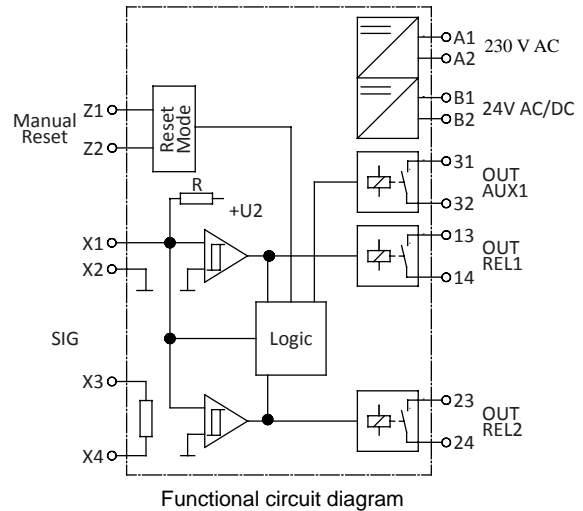

Furthermore, the device can also evaluate a sensor in four-wire technology.

If the desired steady-state current flows, the safety relays are driven and the switching contacts closed.

If the sensor is operated or the sensor circuit is interrupted, the relay switching contacts open.

A signal output with potential-free switching contacts is available. An operation of the sensor causes a reaction of the signal output in accordance with the DIP switch configuration. The signal output must not execute any safety-orientated functions. It is not fail-safe and not checked by testing either.

The switching device has been designed and type-approved in accordance with EN ISO 13849-1 "Safety- related parts of control systems" for category 3 Performance Level e. For compliance with category 3, the safety output is set up redundantly with two independent switching elements.

In addition the device has been type-approved according to EN 62061 "Functional safety of safety-related electrical, electronic and programmable electronic control systems" and can meet a safety function up to SIL 3.

The monitoring state of the sensor and the applied operating voltage are indicated by LED. If there is a fault alarm, all safety outputs are inactive.

The unit can be used in a household environment as well as an industrial environment up to an altitude of 2000m above mean sea level. The unit must not be operated in areas with major temperature changes.

4.

#### Intended use

The switching device can only fulfill its safety-relevant task, if it is used as intended within specifications.

The intended use of the switching device is the use as a protection system in connection with safety contact mats, safety bumpers and safety contact edges with 8.2 kΩ resistance for steady-state current monitoring. It is not allowed to use the safety relay in heights over 2000 m above sea level or potentially explosive atmospheres.

A different use or any use going beyond the intended use is not within specifications. The manufacturer does not accept any liability for any damage arising from use not within specifications.

Any use for special applications requires prior release by the manufacturer.

5.

#### Application example

Safety-orientated monitoring of a safety contact strip with start release via release pushbutton and separate continuation of the control circuits (category 3 compliant application according to EN ISO 13849-1).

In order to check the functionality of the load breaking K1 and K2 relays the break contacts of these contactors are integrated into the start circuit (Z1 Z2).

The signaling relay output is used to visualize the switching state of the safety contact strip. Circuit diagram in voltage-free state. Sensor not operated.

1 Sensor (edge, mat or bumper)

2 Release key

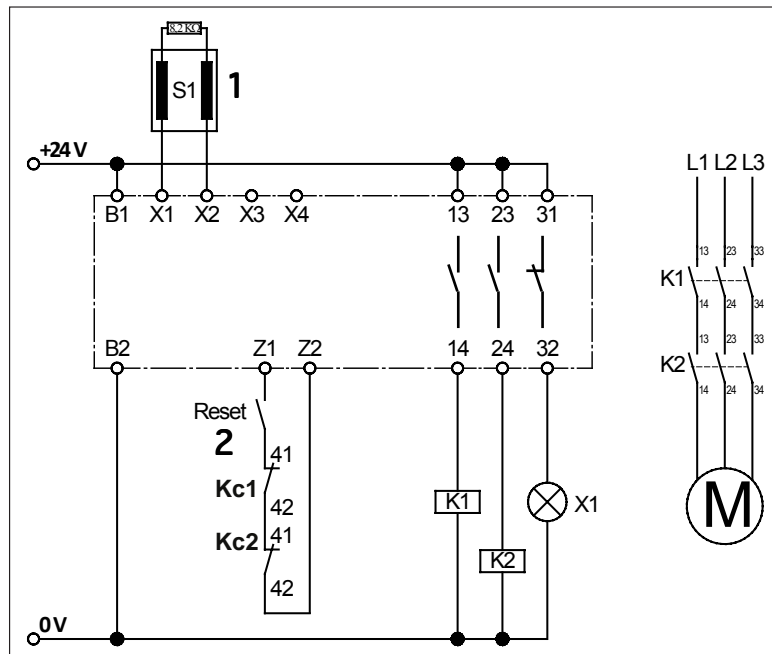

Example  
Switch off via  
Load contactors

Bridge between  
14 and 23  
**remove !**

31-32 with RLU function

Dip switch  
Observe the setting

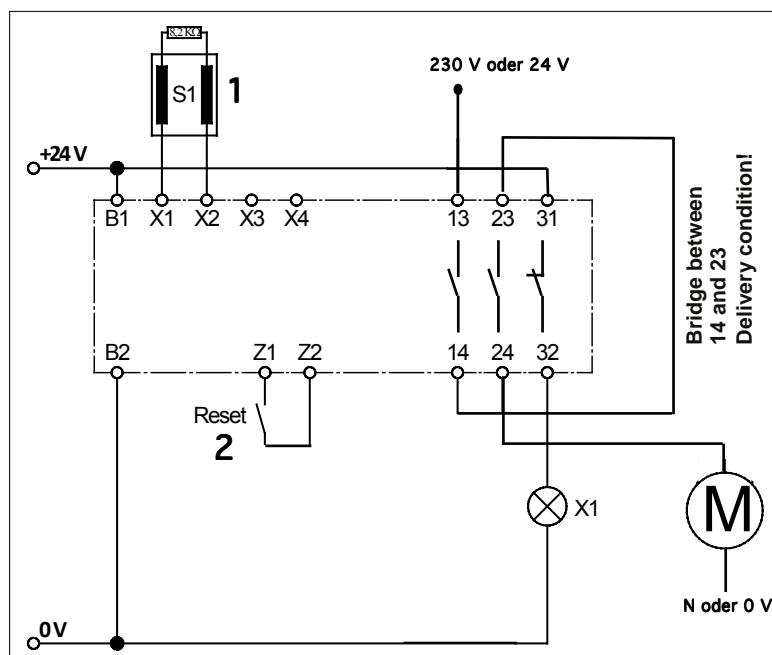

Example  
Direct shutdown

max.  
Switching voltage  
note !

**Bridge between  
14 and 23  
Delivery condition!**

31-32 with RLU function

Dip switch  
Observe the setting

6.

#### Device overview

Version	STM STK 41-322 RLU
Housing	Housing in 22.5 mm width of polyamide to 35 mm DIN mounting rail mounting acc. To EN 60715.
Mains voltage	230 V 50/60 Hz und 24 V AC/DC
signal relay (Switching contact 31 32)	Switches as long as the signal generator is actuated or an error of the signal generator is signaled.

#### 6.1 Versions

#### 6.2 Signal indicators

LED Power (green)

Operating state (on)

Fault alarm (pulse)

LED CH 1 (red)

Sensor operated (on)

Sensor power circuit interrupted (fast flashing)

Fault self-retaining (slow flashing)

LED AUX 1 (yellow)

Signal output switched

If there is no fault alarm, then the operating state is shown via the Power LED (on). When a fault alarm is issued, the number of pulses output indicates the fault:

Pulse	Fault alarm
1x	Voltage supply outside the valid value range
2x	Fault when testing signal input
3x	Output control relay faulty
4x	Data transmission between micro-controllers faulty

#### 6.3 Connection terminals

A1 - A2 Supply voltage 230 V 50/60 Hz

B1 - B2 Supply voltage 24 V AC/DC

X1 - X2 Connection sensor

X3 - X4 Internal terminating resistor

13 - 14 Switching contact safety relay 1

23 - 24 Switching contact safety relay 2

31 - 32 Switching contact signal relay

Z1 - Z2 Connection manual reset /re-start (key NO; optional)

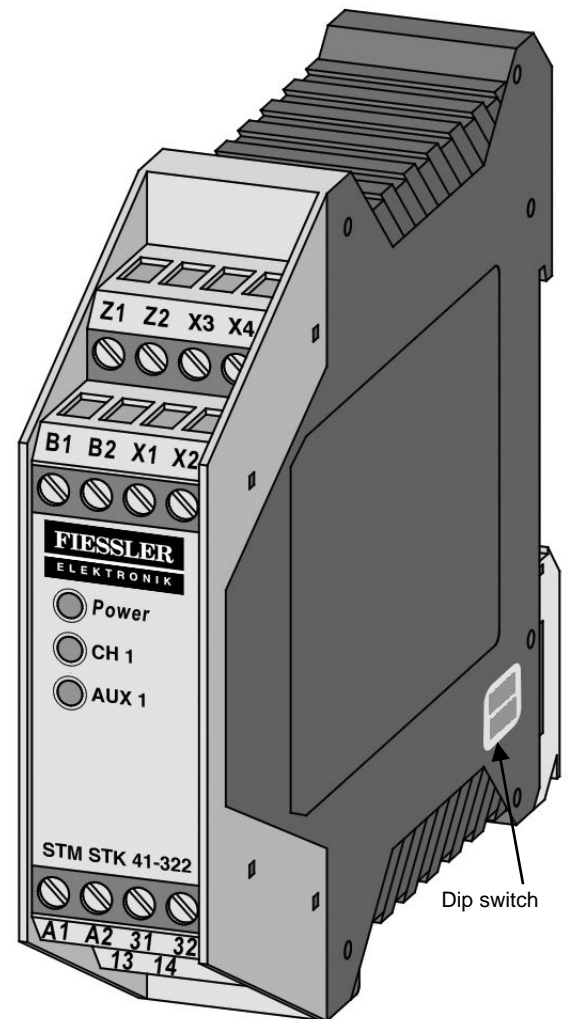

#### 6.4 DIP switch for configuring the operating mode

S1

„ON“: Automatic reset

„OFF“: Fault self-retaining – manual reset **(factory setting)**

S2

„ON“: AUX1 Mode signal output: RLU

„OFF“: AUX1 Mode signal output: RL **(factory setting)**

7.

#### Operating modes

##### 7.1 Safety output

Separate or series-connected output of the control circuits (redundant continuation of the switching contacts).

In order to use the two safety relays separately, the bridge between 14 and 23 must be removed.

##### 7.2 Automatic reset

(S1 = „ON“)

After removing a fault in a sensor circuit or after a voltage failure, the switching unit will automatically release output again.

##### 7.3 Fault self-retaining – manual reset

(S1 = „OFF“)

Following removal a fault of in a sensor circuit, or after a voltage failure, the switching unit will only release the output(s) again, if the Z1 and Z2 contacts, 500 ms after the elimination of the disruption, are closed by means of a pushbutton. This completely prevents any automatic re-start. A permanent bridging of the Z1 and Z2 contacts does not cause an automatic reset.

##### 7.4 Signaling output without any delay (RLU)

(S2 = „ON“)

In this mode of operation the corresponding signaling output is activated without delay, if any fault is signaled on the corresponding channel. The output is always inactive in the de-energized state of the switching device.

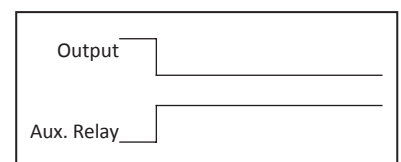

Safety output (symbolic)  
Signaling output (symbolic)

##### 7.5 Signaling output delayed (RL)

(S2 = „OFF“)

In this operating mode the corresponding signaling output is activated with a delay of 0.5 seconds and then remains active for a maximum of 3 seconds, if a fault is signaled.

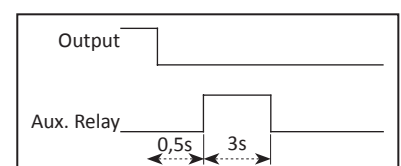

Safety output (symbolic)  
Signaling output (symbolic)

**8.****Mechanical mounting**

The switching unit must be mounted correctly:

In a dust-protected and moisture-protected switch cabinet or casing.

For use in an environment with level 2 contamination.

With a protection type of at least IP54.

On a 35 mm DIN support rail according to EN 50 022.

The switching unit can be installed in any position.

The unit must not be operated in areas with major temperature changes.

**9.****Electrical connection**

The switching unit can be destroyed by connection to the incorrect terminals. Lines that are routed in the open air or outside the switch cabinet must be protected accordingly. The limit values stated in the "Technical Data" for the supply voltage and the switching capability of the relay must be observed

**9.1 Supply voltage**

The supply voltage can optionally be effected by means of a mains voltage of 230 V AC 50/60Hz or a low voltage of 24 V AC/DC. For a supply with 24 V AC/DC the voltage must correspond to the requirements for protective low voltages (SELV). The supply line to the switching device must be protected by means of a 5x20 glass tube fuse 200mA medium time lag

Never apply both voltages simultaneously!

The 230 V (120 V) supply voltage must be applied to the A1 and A2 terminals. For operation with 24 V, the supply voltage must be applied to the B1 and B2 terminals.

For a fixed installation a separating device must be available (for example, a main switch for the system).

A mains plug is sufficient as a separating device, if it is freely accessible.

**9.2 Connection of sensor**

The sensor with a terminating resistor of 8.2 k $\Omega$  must be connected to the X1 and X2 terminals.

The sensor without a terminating resistor is connected to the X1 and X2 terminals by means of one lead and with the other lead to the X3 and X4 terminals

**9.3 Connection of several sensors per sensor circuit**

Fiessler sensors must not be connected in parallel.

One or several sensors can be connected to the signal transmitter input. For this purpose, the individual sensors are connected in series in accordance.

A maximum of 10 safety mats can be connected in series.

The maximum total surface area must not exceed 10 m<sup>2</sup>.

The size of a mat can be up to 1350 x 2350 mm.

The total line length of the series-connected mat must not exceed 25 m.

Before connecting the series-connected sensors, it is recommended to measure the resistance value of the wiring.

In the case of non-operated sensors the resistance must be  $8.2 \text{ k}\Omega \pm 500 \Omega$ . If the sensor is operated, the resistance must not exceed  $500 \Omega$ .

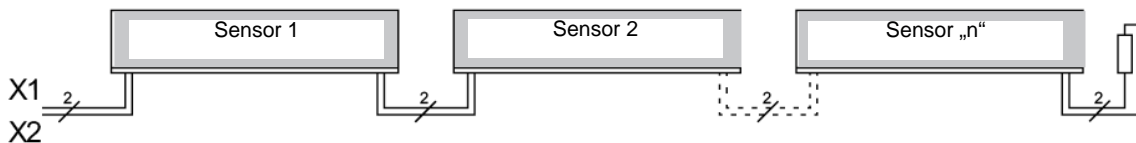

Fig. 1: Interconnecting several sensors, here using the example of the safety contact edge

#### 9.4 Connection of control circuits

Connect the control circuit to be monitored to the 13 and 24 terminals. If the switching contacts are redundantly continued, the factory-inserted bridge between the 14 and 23 terminals must be removed.

In the event of any redundant use of the switching contacts only voltages with the same potential may be connected.

The use of different voltage potentials does not correspond to any intended use within specifications.

Depending on the nominal current, the control circuits are to be protected by a corresponding fuse, or the nominal current on the control circuits must be limited to the maximum value by means of other measures.

#### 9.5 Connection Reset

For the operating mode "manual reset" the necessary reset switch must be connected to the Z1 and Z2 terminals.

#### 9.6 Connection of signaling contact

The 31 and 32 signaling contact only serves as an auxiliary contact (signaling, display etc.) and must not be integrated into the safety circuit.

The signaling contact may only switch extra low voltages (24V). The switching of low voltages (230V) is not permissible.

10.

#### Commissioning and function testing

Following a corresponding connection of all electrical connections and switching on the supply voltage, the system / machine must be checked for correct functionality.

After successful commissioning the 13 and 24 safety output is driven (relay contact "closed"). An operation of the sensor causes an opening of the 13 and 24 relay contact.

The signaling relay (31 32 connection) switches in accordance with the present DIP switch position. This is indicated by means of the yellow AUX1 LED.

The safety system must be inspected by competent specialists at suitable intervals. The check must be documented in a way that allows it to be traced at any time. The requirements of the system / machine manufacturer are to be taken into account and observed.

11.

#### Fault diagnosis

LED	Fault	Fault removal
green <b>Power</b> LED does not light up	Supply voltage is missing, too low or incorrectly connected.	Check connections and supply voltage: - 230 V AC (or 120 V) at terminals <b>A1 A2</b> or - 24 V AC/DC at terminals <b>B1 B2</b> Tolerance range: $\pm 10\%$
green <b>Power</b> LED flashes cyclically (pulse output)	Internal fault is indicated by the number of pulses.	See -> signal displays
red <b>CH1</b> LED lights up	The corresponding sensor is recognized as being operated.	- Check the connections of the corresponding sensors (squeezed or brittle supply lines, etc.) - Check signal sensor *
red <b>CH1</b> LED fast flashing	Sensor circuit interrupted, sensor not connected, defectively connected or defective.	- Check the connections of the corresponding sensors (squeezed or brittle supply lines, etc.) - Check signal sensor *
red <b>CH1</b> LED slow flashing	Fault self-retaining	Carry out manual reset

If the supply voltage is correctly wired and applied, only the green Power LED may be lit up.

If the red LED illuminates, there is a fault in the system which can be delimited by means of the LED.

\* If the fault is not found in the wiring, the function of the electronic system can be checked by applying a resistance of 8.2 k $\Omega$  to the sensor-input on the switching device. Subsequently, if the electronics work perfectly, the sensor must be checked by means of an ohmmeter. For this purpose, the connection of the sensor to the switching device must be separated and connected by means of an ohmmeter. In the case of a non-operated sensor the resistance must be 8.2 k $\Omega$   $\pm$  500  $\Omega$ .

If the sensor is operated, the resistance must not exceed 500  $\Omega$

12.

#### Decommissioning and disposal

The products manufactured by Fiessler are exclusively intended for commercial use (B2B). At the end of use, the products must be disposed of according to all local, regional and national regulations. Fiessler is also happy to take back the products and disposes of them properly.

13.

#### Technical data

#### Supply voltage

Mains voltage	U <sub>Netz</sub>	230 V AC 50/60 Hz
Low voltage	U <sub>E</sub>	24 V AC/DC ±10%
Power consumption	P <sub>Netz_max</sub>	2,2 VA 230 V AC (oder 115 V)
	P <sub>E_max</sub>	1,5 W 24 V DC
	P <sub>E_max</sub>	1,2 VA 24 V AC

#### Safety relay

Nominal current DC	2 A (30 V DC)
Nominal current AC	1 A (230 V AC)
Mechanical service life	>10 <sup>6</sup> operations
Switch-off delay (reaction time)	< 10 ms
Switch-on delay	500 ms (Power on 700ms)
Utilization category	AC-15 (230V AC; 1A; 800000 Op.) DC-13 (30V DC; 2A; 250000 Op.)

Housing: Polyamide PA 6.6,

Self-extinguishing according to UL 94-V2

Dimensions (HxWxD): 99 x 22,5 x 114 mm

Protection type: IP20

Protection: class II (protective insulation)

Pollution Degree: 2

Overtoltage category: III

Rated insulation voltage: 250 V

Rated impulse voltage resistance: 4,00 kV

Weight: 210 g

Temperature range single mounting: -20 °C bis +55 °C

Temperature range mounting in row: max. 35 °C

Connection cable cross-section: single- or fine-stranded cable 0,75-1,5 mm<sup>2</sup>

#### Certifications

STK 41-322 RLU:

EN ISO 13849-1:2008 Category 3 PL d (MTTFd 195 years, DC 99 %)

EN 62061:2013 SILCL 3

(PFHd 6,51E-09 1/h)

Electronics: MTTFd 625 years, DC 99 %

Electromechanics: B10d 500000

MTTFd 285 years, DC 99% (Nop 17520)

#### Terminating resistor – sensor

Nominal value	R <sub>Nom</sub>	= 8,2 kΩ
upper switching value	R <sub>AO</sub>	> 12,0 kΩ
lower switching value	R <sub>AU</sub>	< 5,0 kΩ

#### Signal relay

Max. switching current	2 A (30 V AC/DC)
Mechanical service life	>10 <sup>6</sup> operations
Operating mode RL: Switch-on delay	0,5 Sek.
Operating mode RL: Switch-on duration	< 10 ms

With the RLU version, the signal relay switches synchronously to the operation of the signal transmitter.

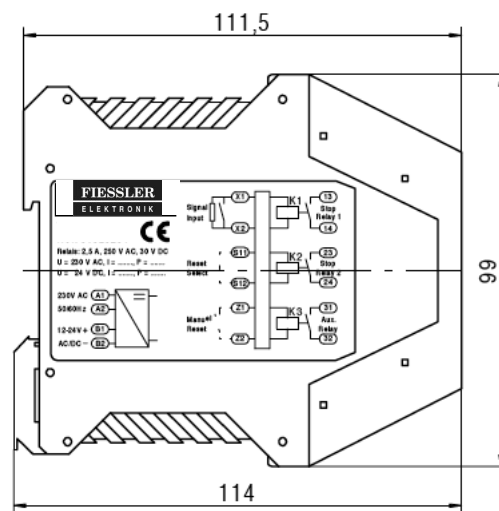
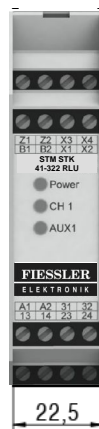

## Other safety equipment

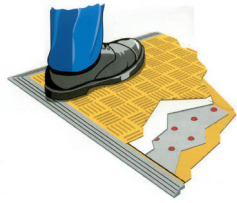

Safety mats



Safety foot pedal

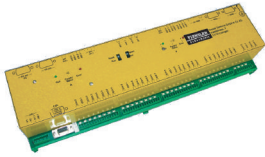

Safety PLC  
Programmable Safety Centre  
FPSC

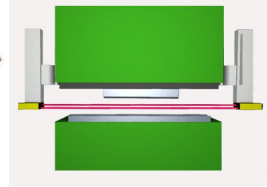

Press brake protection  
system AKAS

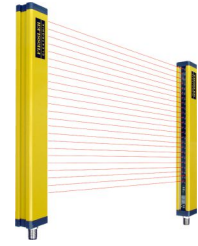

Safety light curtain

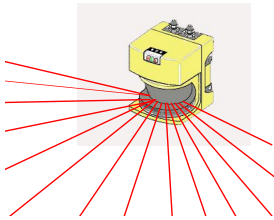

Proximity laser scanner



Single-beam safety light  
barriers with extra large  
detection range

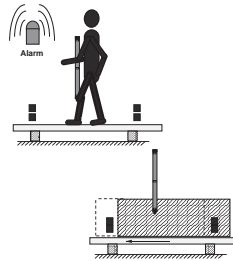

Safety light grid with muting function

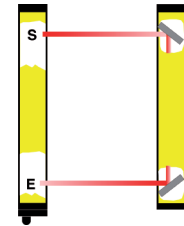

Safety light grid

## Service

As a special feature for training our customers, Fiessler Elektronik offers one-day safety workshops. Our service team provides you with expert advice and information for the reliable integration of our safety equipment into your machine.

## Homologations

In order to ensure and maintain the high quality level of the Fiessler safety products, a quality control security system has been established early. Fiessler Elektronik holds the DIN ISO EN 9001 Certificate and, thanks to the company-owned EMC laboratory, all products must pass an inspection without exception before they leave the company. All safety equipment comply with the applicable national and international standards. Development and Design is made in close co-operation with the German employer's liability insurance associations. All homologations are obtained only after having passed strict tests by the German surveyor organisation TÜV.



## Award of appreciation

for exemplary performance in the development of the press brake protection system AKAS.

The award was bestowed upon Fiessler Elektronik by the ministry of trade and commerce of the federal state of Baden-Württemberg.



**Fiessler Elektronik  
GmbH & Co. KG  
Buchenteich 14  
D-73773 Aichwald**

Telefon: ++49(0)711-91 96 97-0  
Fax: ++49(0)711-91 96 97-50  
Email: [info@fiessler.de](mailto:info@fiessler.de)  
Internet: [www.fiessler.de](http://www.fiessler.de)

Fiessler Elektronik has representations in all major industrial nations.

