

**ULSG
ULSG/DUO
ULSG3
ULSG6**

Operating manual



Series ...LCT



Series ...LVT

ULSG:
voltage supplying
contactor control,
restart interlock,
potentialfree output contacts

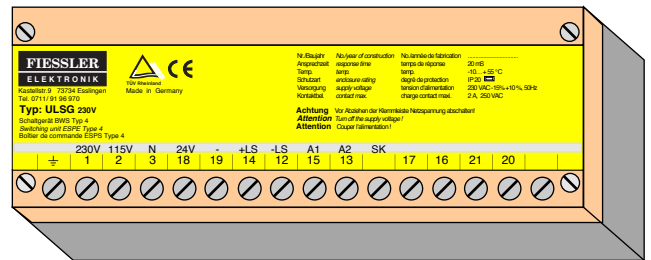

ULSG DUO:
like ULSG however
connection for 2 light
curtains

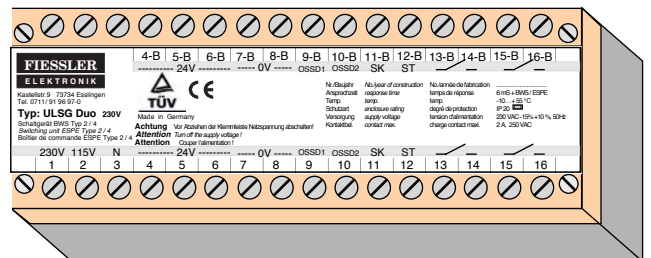

**ULSG 3
ULSG 6:**
like ULSG however
connection for up to 3
light curtains,
or
connection for up to 6
light curtains,
without voltage
supplying

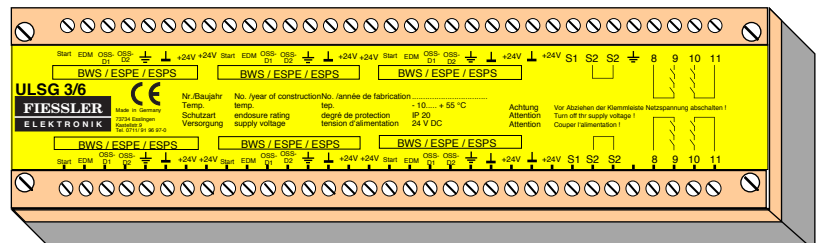

TABLE OF CONTENTS:

Safety instructions



Application notes

Electric connection

Technical datas



**For over 50 years,
we have specialized in the area of
opto-electronics.**

Our experience is your gain.

**Tell us your problems and we will
be pleased to advise you.**

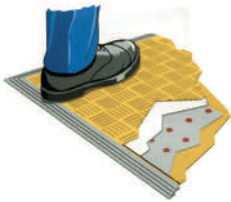

Footmats

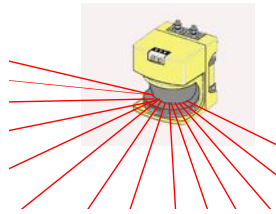

Laser scanners

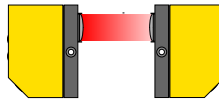

Single-beam safety light barriers with a long range (up to 150 m)

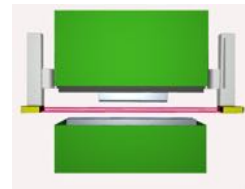

Press brake protection system AKAS®

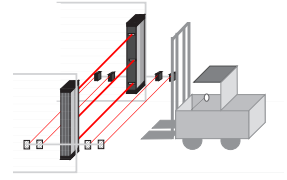

Differentiation between humans and machines by muting function

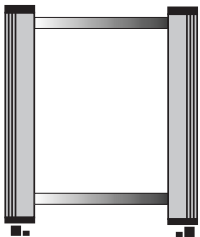

Two-beam light grids with a range of up to 60 m

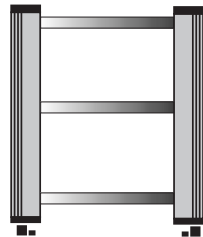

Three- or more beam light grids with a range of up to 60 m

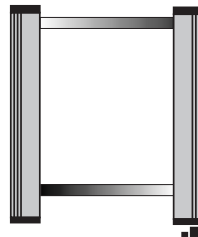

Two-beam light grids with transmitter / receiver units and a deflecting mirror with a range of up to 10 m

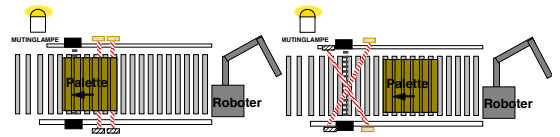

Output muting: Differentiation between humans and material

Cross-muting: Differentiation between humans and material / machines

FieSSLer Elektronik GmbH & Co. KG
D-73773 Aichwald

Phone: ++49(0)711-91 96 97-0
Fax: ++49(0)711-91 96 97-50
Email: info@fiessler.de
Internet: www.fiessler.de

Represented in all major importing



We also invest in environmental safety

Chapter Contents	Page
1. Safety instructions	4
2. Electrical connection	5
2.1 Connection of ULSG with restart interlock / with contactor control (EDM) / with external contactors.....	5
2.2 Connection of ULSG with restart interlock / with contactor control (EDM) / without external contactors.....	6
2.3 Connection of ULSG ohne Wiederanlaufsperr / ohne Kontrolle der nachfolgenden Schaltglieder	7
2.4 Connection of ULSG DUO	8
2.5 ULSG 3/6 : Connection for up to 6 light curtains (24 V DC) of the series ...LVT	9
2.5 ULSG 3/6 Connection for up to 6 light curtains (24 V DC) of the series ...LCT	10
2.6 Connection of ULSG 3/6 with restart interlock / with contactor control (EDM) / with external contactors	11
2.7 Connection of ULSG 3/6 with restart interlock / with contactor control (EDM) / without external contactors	12
3. Dimensional drawings	13
4. Technical Datas	14
5. Service / Maintenance / Warranty	15



Refer to the light curtain operating manual for important notes and constraints.



All safety instructions are marked with this symbol and must be observed in particular!



Safe functionality of the entire installation is guaranteed only if this operating manual and applicable accident-prevention regulations are observed. Forming part of the controller's scope of delivery, this operating manual must be kept at the controller's site of use.

All instructions in this operating manual must be strictly observed. The manual provides the user with important information concerning proper use of the safety controllers.

Observe applicable standards and guidelines when using the safety controllers. Local authorities or trade associations will provide you with the relevant information. All other applicable regulations and standards issued by the employer's liability insurance associations must be observed too.

Qualified personnel Installation, commissioning and maintenance must only be carried out by qualified personnel.

Danger signs Before commissioning and operating a machine with a safety controller, ensure that nobody is located in the danger zone. A danger sign to this effect must be affixed to the machine.

Light barriers do not provide any protection against flying objects produced through operation of the machine.

During a use of safety light curtains with an external controller or other secondary control units,

operative or organizational measures should ensure deactivation / testing at least once every 24 hours in order to detect and subsequently eliminate any faults on the controllers.

Ensure daily inspection (after 24 hours at the latest):

Using the test rod*, interrupt the light barrier on the transmitting side from the start to the end of the protective field so that the light field is only covered by this part. The green LED (or the yellow LED in the operating mode with restart interlock) must not light up from start to finish.

* The test rod's diameter must correspond to the detection capacity indicated on the receiver's type plate.

Prerequisites for the use of safety light curtains:

- The **safety distance** between the protective field and hazardous area must be large enough to ensure that, during entry into the protective field, the hazardous points cannot be reached before the hazardous movement is interrupted or ended.
- **Access to the hazardous area** must only be possible through the protective field (reaching under, over or around the field must not be possible).
- **Passing through the light curtain** must only be possible if the **restart interlock** is activated on interruption of the light curtain. A new command to activate the next hazardous machine movement must only be implemented via an enabling switch. This start button must not be operable from the hazardous area and must be located at a point from which the accessible area can be viewed without obstruction.
- It must be possible for the hazardous condition of a machine to be terminated by the sensor function.
- Unintentional repetition of a hazardous movement must be prevented by appropriate safety facilities.
- The **safety category** (type 4) of the accident-prevention light curtain should be at least the same as the safety category of the machine control unit.
- **Acceptance test:**
The acceptance test for the installation should be carried out by competent personnel who are in possession of all information provided by the supplier of the machine and the BWS.
- **Annual inspections:**
The operator must ensure that a competent person is assigned the task of inspecting the light curtain and its machine interface on a yearly basis. This person may, for example, be employed by the light curtain's manufacturer or the operator.

On request by the customer, Fiessler Elektronik carries out the acceptance test and annual inspections. In addition, seminars providing customers with training in annual inspections are held at regular intervals.

2.1 Connection with restart interlock / with contactor control (EDM) / with external contactors

External contactors control hazardous movement

If the protective field is clear and the start button is operated, potential-free output contacts 13-14 and 15-16 close, and connected contactors K1 and K2 are engaged. If the protective field is interrupted, the NO-contacts of K1 and K2 open and the movement is interrupted.

Only if both contactors / valves K1 and K2 are switched off and the protective field is clear again, a new duty cycle or movement is possible by actuating the start button.

Connection pin 4 (EDM) on the light curtain can be used to control the contactor or hydraulic valves K1 and K2.

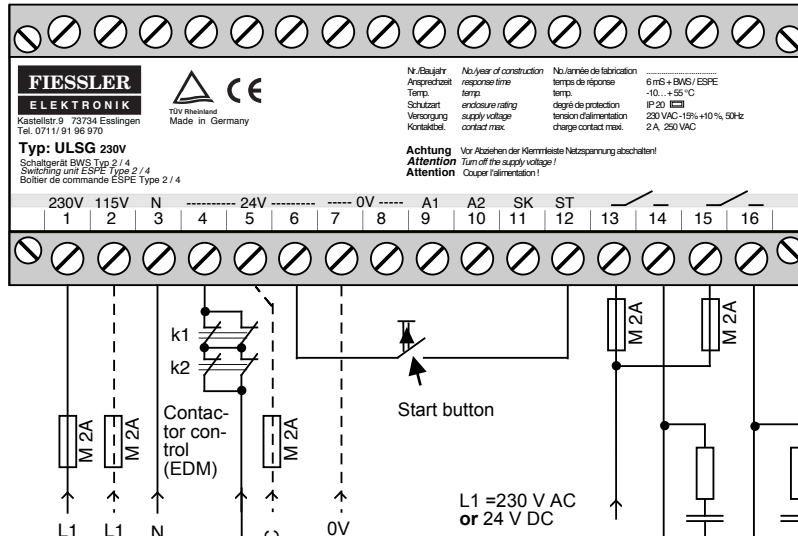

X = To interrupt hazardous movement

To commence closure by contactors K1 and K2, their NO-contacts must be connected in series.

The output contacts 13-14 & 15-16 are potential-free, force-guided and normally open with a maximum loading capacity of 2 A/250 V AC or 60 V DC, 30 W.

If an inductive load is employed, it (not the contacts) must be connected in parallel with spark quenching elements (for example, 0.22 µF, 220 Ω).

Supply voltage options:

- Terminal 1 & 3: 230 V AC -15%+10%
- or
- Terminal 2 & 3: 115 V AC -15%+10%
- or
- Terminal 5 & 7: 24 V DC -10%+20%

ULCT- / BLCT- / TLCT- / ILCT-receiver:

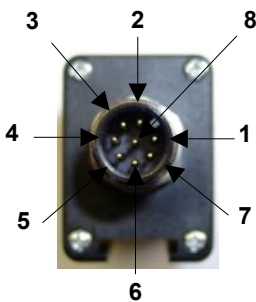

- 1 / white: Start — ST Terminal 12
- 2 / brown: +UB — 24V Terminal 4, 5 or 6
- 4 / yellow: EDM — Terminal 4
- 5 / grey: OSSD1 — A1 Terminal 9
- 6 / pink: OSSD2 — A2 Terminal 10
- 7 / blue: -UB — 0V Terminal 7 or 8

Operation mode of ...LCT:

- with contactor control
- with restart interlock

Display during power on:



TLVT / ILVT-receiver:

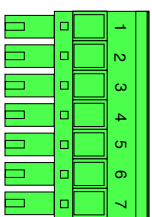

- 1 : OSSD1
- 2 : OSSD2
- 3 : Start
- 4 : EDM
- 5 :
- 6 : -UB
- 7 : +UB

ULVT / BLVT-receiver:

- 1 : Start — ST Terminal 12
- 2 : EDM — Terminal 4
- 3 : OSSD1 — A1 Terminal 9
- 4 : OSSD2 — A2 Terminal 10
- 5 :
- 6 : -UB — 0V Terminal 7 or 8
- 7 : +UB — 24V Terminal 4, 5 or 6

Operation mode of ...LVT:

- with contactor control
- with restart interlock
- synchronized outputs

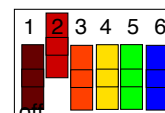

Attention: TLVT/ILVT and ULVT/BLVT has to be connected differently!

2.2 Connection with restart interlock / with contactor control (EDM) / without ext. contactors

The internal safety relays control hazardous movement.

If the protective field is clear and the start button is operated, the potential-free output contacts 13-14 and 15-16 close, and hazardous movement is start.

If the protective field is interrupted, the internal safety relays open and the movement is interrupted.

Only If both internal safety relays are switched off and the protective field is clear again, a new duty cycle or movement is possible by actuating the start button.

Terminal 2 (EDM) on the light curtain and Terminal 11 (SK) on the ULSG can be used to additionally control the internal safety relays.

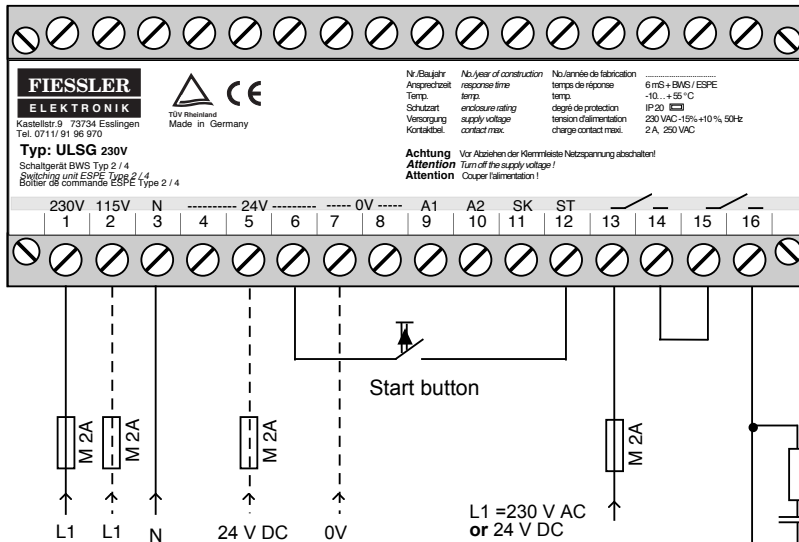

The output contacts 13-14 & 15-16 are potential-free, force-guided and normally open with a maximum loading capacity of 2 A/250 V AC or 60 V DC, 30 W.

If an inductive load is employed, it (not the contacts) must be connected in parallel with spark quenching elements (for example, 0.22 µF, 220 Ω).

Supply voltage options:

- Terminal 1 & 3: 230 V AC -15%+10%
- or
- Terminal 2 & 3: 115 V AC -15%+10%
- or
- Terminal 5 & 7: 24 V DC -10%+20%

Voltage depends on the drive type:

N or 0V

ULCT- / BLCT- / TLCT- / ILCT-receiver:

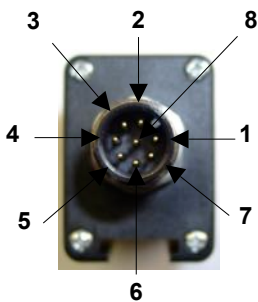

- 1 / white: Start ———— ● ST Terminal 12
- 2 / brown: +UB ———— ● 24V Terminal 4, 5 or 6
- 4 / yellow: EDM ———— ● SK Terminal 11
- 5 / grey: OSSD1 ———— ● A1 Terminal 9
- 6 / pink: OSSD2 ———— ● A2 Terminal 10
- 7 / blue: -UB ———— ● 0V Terminal 7 or 8

Operation mode of ...LCT:
- with contactor control
- with restart interlock

Display during power on:



TLVT / ILVT-receiver:

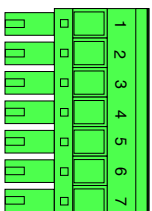

- 1: OSSD1
- 2: OSSD2
- 3: Start
- 4: EDM
- 5:
- 6: -UB
- 7: +UB

ULVT / BLVT-receiver:

- 1: Start ———— ● ST Terminal 12
- 2: EDM ———— ● SK Terminal 11
- 3: OSSD1 ———— ● A1 Terminal 9
- 4: OSSD2 ———— ● A2 Terminal 10
- 5:
- 6: -UB ———— ● 0V Terminal 7 or 8
- 7: +UB ———— ● 24V Terminal 4, 5 or 6

Operation mode of ...LVT:
- with contactor control
- with restart interlock
- synchronized outputs

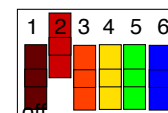

Attention: TLVT/ILVT and ULVT/BLVT has to be connected differently!

2.3 Connection without restart interlock / without control of the follow-up circuit

The safeguarded machine control system or the safety PLC control hazardous movement.

If the protective field is interrupted, the internal safety relays open and the movement is interrupted by the follow-up safety control. Only if both internal safety relays are switched off and the protective field is clear again, a new duty cycle or movement is possible.

Terminal (EDM) on the light curtain and Terminal 11 (SK) on the ULSG can be used to additionally control the internal safety relays.

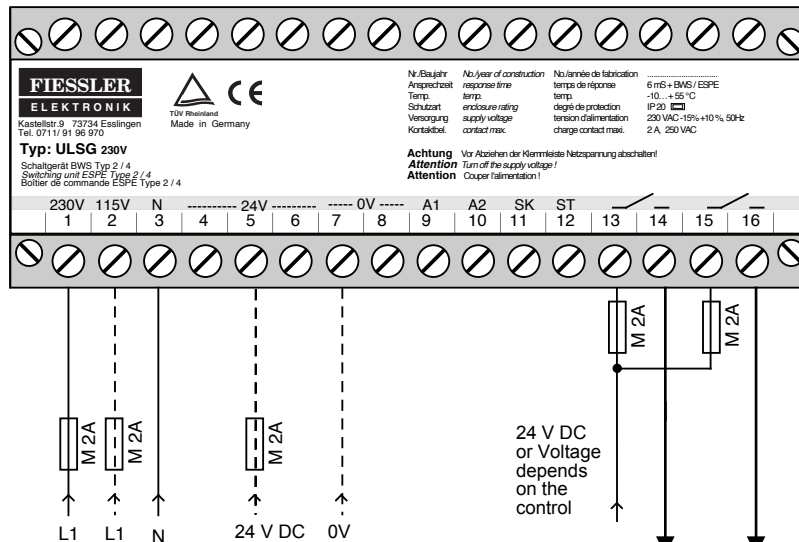

The connected, safeguarded control system must monitor the subsequent switching elements and possess a restart interlock depending on the application involved.

Supply voltage options:

- Terminal 1 & 3: 230 V AC -15%+10%
- or
- Terminal 2 & 3: 115 V AC -15%+10%
- or
- Terminal 5 & 7: 24 V DC -10%+20%

Input E1 Input E2
Safeguarded machine control or safety PLC with monitoring of the subsequent switching elements.

ULCT- / BLCT- / TLCT- / ILCT-receiver:

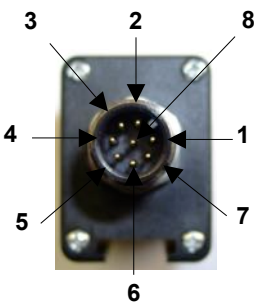

- 1 / white: Start — 24V Terminal 4, 5 or 6
- 2 / brown: +UB — 24V Terminal 4, 5 or 6
- 4 / yellow: EDM — SK Terminal 11
- 5 / grey: OSSD1 — A1 Terminal 9
- 6 / pink: OSSD2 — A2 Terminal 10
- 7 / blue: -UB — 0V Terminal 7 or 8

Operation mode of ...LCT:
- with contactor control
- without restart interlock

Display during power on:



TLVT / ILVT-receiver:

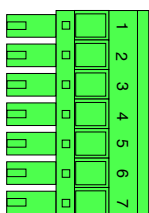

- 1: OSSD1
- 2: OSSD2
- 3: Start
- 4: EDM
- 5:
- 6: -UB
- 7: +UB

ULVT / BLVT-receiver:

- 1: Start — 24V Terminal 4, 5 or 6
- 2: EDM — SK Terminal 11
- 3: OSSD1 — A1 Terminal 9
- 4: OSSD2 — A2 Terminal 10
- 5:
- 6: -UB — 0V Terminal 7 or 8
- 7: +UB — 24V Terminal 4, 5 or 6

Operation mode of ...LVT:
- with contactor control
- without restart interlock
- synchronized outputs

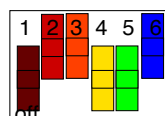

Attention: TLVT/ILVT and ULVT/BLVT has to be connected differently!

2.4 Connection ULSG DUO (see the connection of ULSG)

The connection of the ULSG DUO takes place similarly to the ULSG.

The Terminals **4 - B** to **16 - B** takes place similarly to the connection of the Terminals **4** to **16** on ULSG

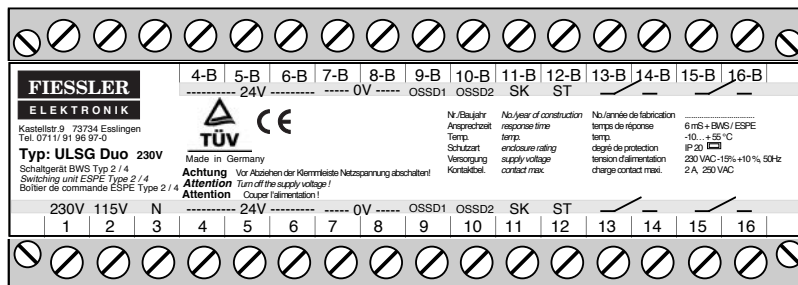

The Terminals **1** to **16** takes place similarly to the connection of the Terminals **1** to **16** on ULSG

2.5 Connection of up to 6 safety light grids of the series ...LVT to ULSG 3 / ULSG 6
(only for 24 V DC connection)

Attention: TLVT/ILVT and ULVT/BLVT has to be connected differently!

TLVT / ILVT- receiver:		ULVT / BLVT- receiver:
1 : OSSD1	↘	1 : Start
2 : OSSD2	↗	2 : EDM
3 : Start	↘	3 : OSSD1
4 : EDM	↗	4 : OSSD2
5 :		5 :
6 : -UB	→	6 : -UB
7 : +UB	→	7 : +UB

Terminal (EDM) of the light curtain and Terminal (EDM) of the ULSG3 / ULSG6 are used, in order to supervise the internal safety relays. (Output contacts 8 - 9 and 10 - 11).

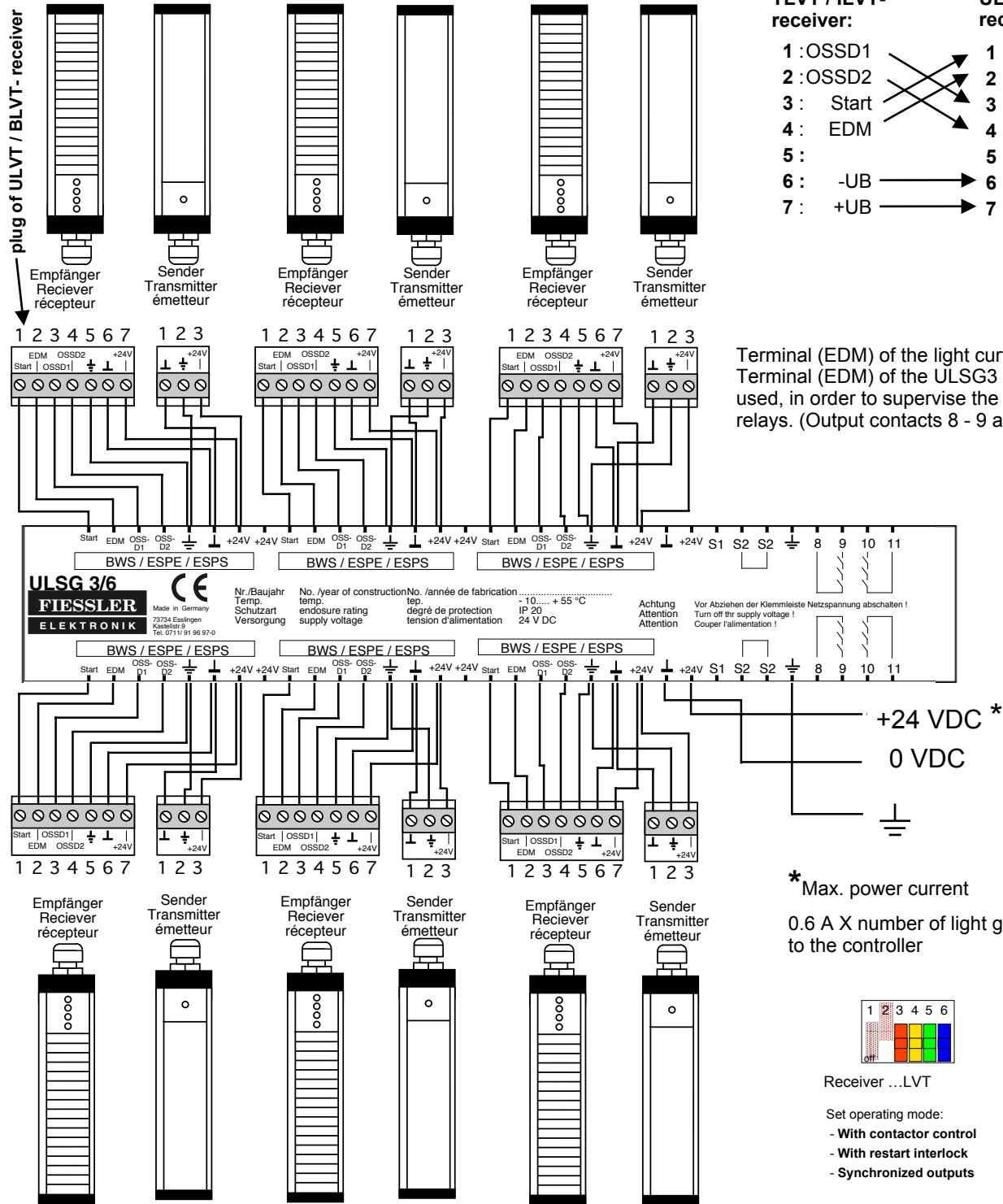

*Max. power current
0.6 A X number of light grids connected to the controller



Receiver ...LVT

- Set operating mode:
- With contactor control
 - With restart interlock
 - Synchronized outputs



Important note !!!

If not all 3 or 6 light grids are connected, +24 V must be applied to the free OSSD- terminals on the ULSG3/6.

2.6 Connection of up to 6 safety light grids of the series ...LCT to ULSG 3 / ULSG 6 (only for 24 V DC connection)

ULCT- / BLCT- / TLCT- / ILCT-receiver:

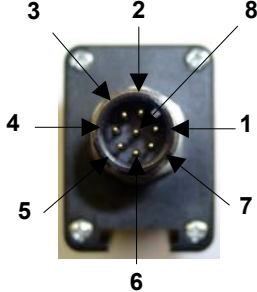

Operation mode of ...LCT:
 - with contactor control
 - with restart interlock

Terminal 4 (EDM) of the light curtain and Terminal (EDM) of the ULSG3 / ULSG6 are used, in order to supervise the internal safety relays. (Output contacts 8 - 9 and 10 - 11).

Display during power on:

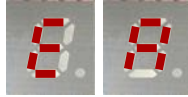

1 / white: Start	4 / yellow: EDM	5 / grey: OSSD1	6 / pink: OSSD2	7 / blue: -UB	2 / brown: +UB
1 / white: Start	4 / yellow: EDM	5 / grey: OSSD1	6 / pink: OSSD2	7 / blue: -UB	2 / brown: +UB
1 / white: Start	4 / yellow: EDM	5 / grey: OSSD1	6 / pink: OSSD2	7 / blue: -UB	2 / brown: +UB

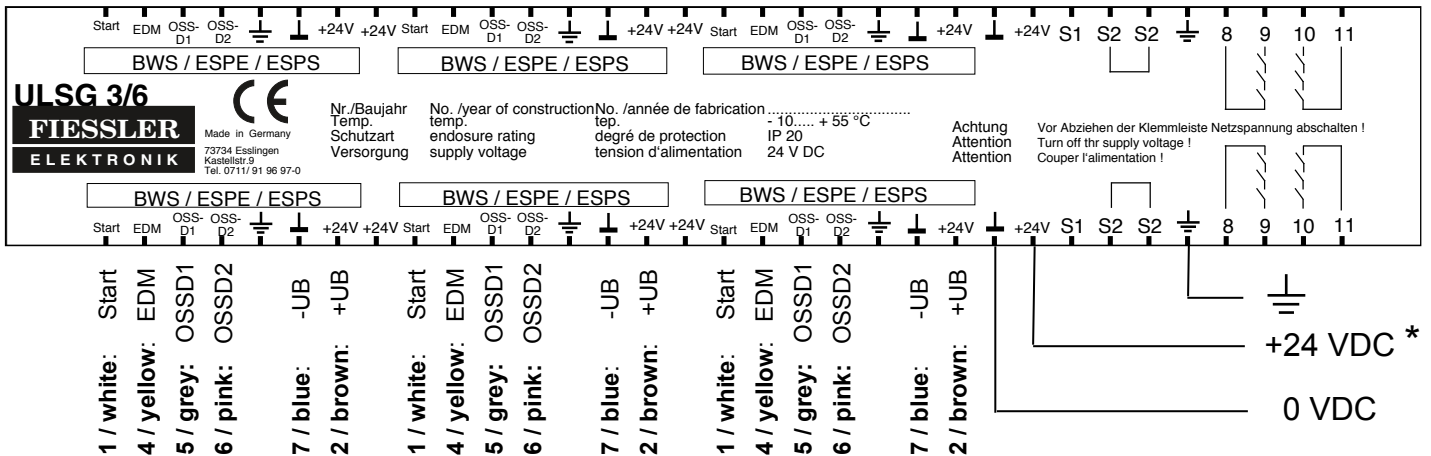

Important note !!!

If not all 3 or 6 light grids are connected, +24 V must be applied to the free OSSD- terminals on the ULSG3 / ULSG6.

* Max. power current

0.6 A X number of light grids connected to the controller

ULCT- / BLCT- / TLCT- / ILCT-transmitter:

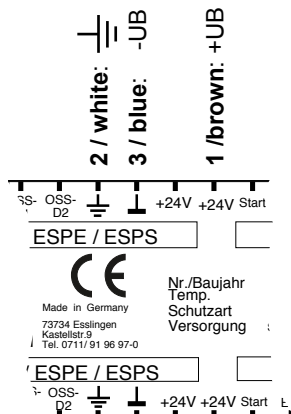
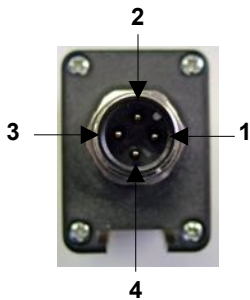

exemplary connection of a transmitter,

The connection of the other transmitter takes place accordingly

2.7 Connection with restart interlock /with contactor control (EDM) /with external contactors

Terminal (EDM) of the light curtain and Terminal (EDM) of the ULSG3 / ULSG6 are used, in order to supervise the internal safety relays. (Output contacts 8 - 9 and 10 - 11).

Application examples

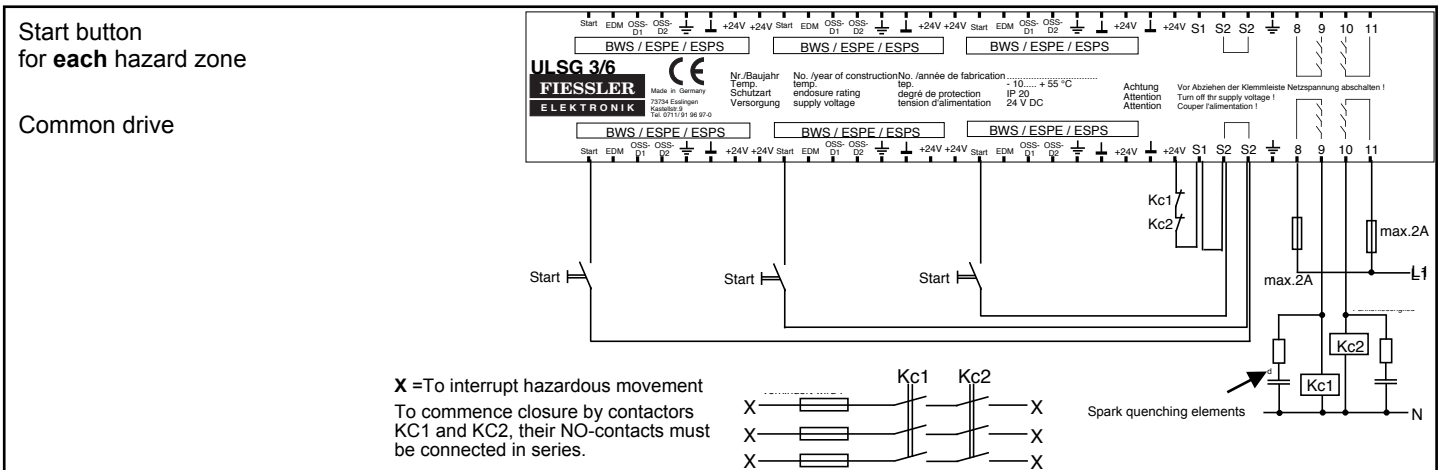
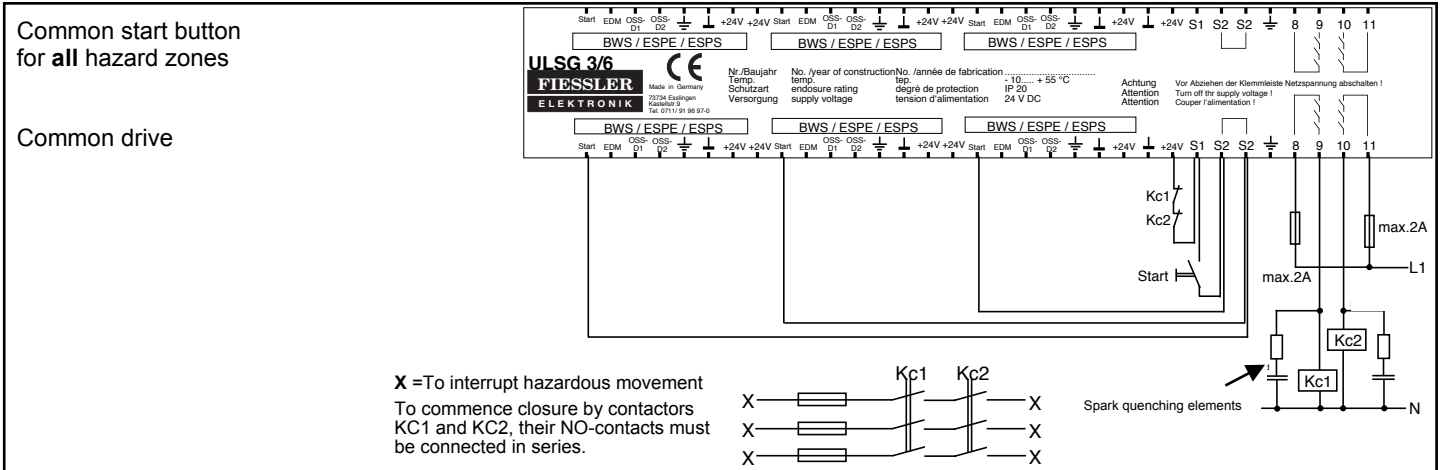

If 6 light grids are employed, they are to be connected via the top and bottom terminals.

Output contacts 8 -9 and 10 -11 of the upper terminal side are separated from output contacts 8 -9 and 10 -11 of the lower terminal side. These can be connected in series if necessary:

8 - 9 (top) in series with 8 - 9 (bottom), 10 - 11 (top) in series with 10 - 11 (bottom)

If not all 3 or 6 light grids are connected, +24 V must be applied to the free OSSD- terminals on the ULSG3/6.

2.8 Connection with restart interlock / with contactor control (EDM) / without external contactors

Terminal (EDM) of the light curtain and Terminal (EDM) of the ULSG3 / ULSG6 are used, in order to supervise the internal safety relays. (Output contacts 8 - 9 and 10 - 11).

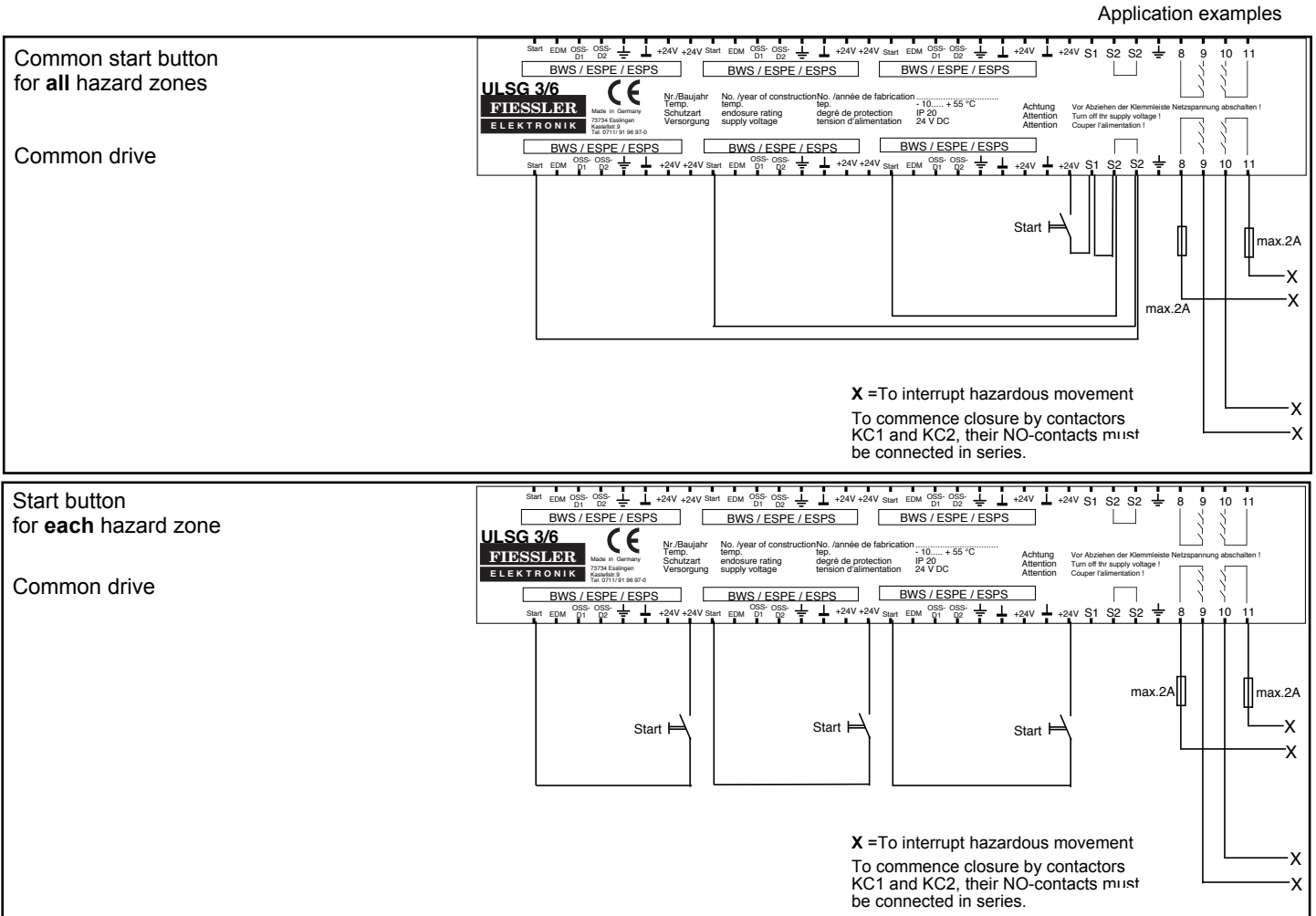

If 6 light grids are employed, they are to be connected via the top and bottom terminals.

Output contacts 8 - 9 and 10 - 11 of the upper terminal side are separated from output contacts 8 - 9 and 10 - 11 of the lower terminal side. These can be connected in series if necessary:
8 - 9 (top) in series with 8 - 9 (bottom), 10 - 11 (top) in series with 10 - 11 (bottom)

If not all 3 or 6 light grids are connected, +24 V must be applied to the free OSSD- terminals on the ULSG3/6.

If the output contacts are connected to a safeguarded machine control or safety PLC, the safeguarded control system must monitor the subsequent switching elements.

3. Dimensional drawings

ULSG:
ULSG DUO:

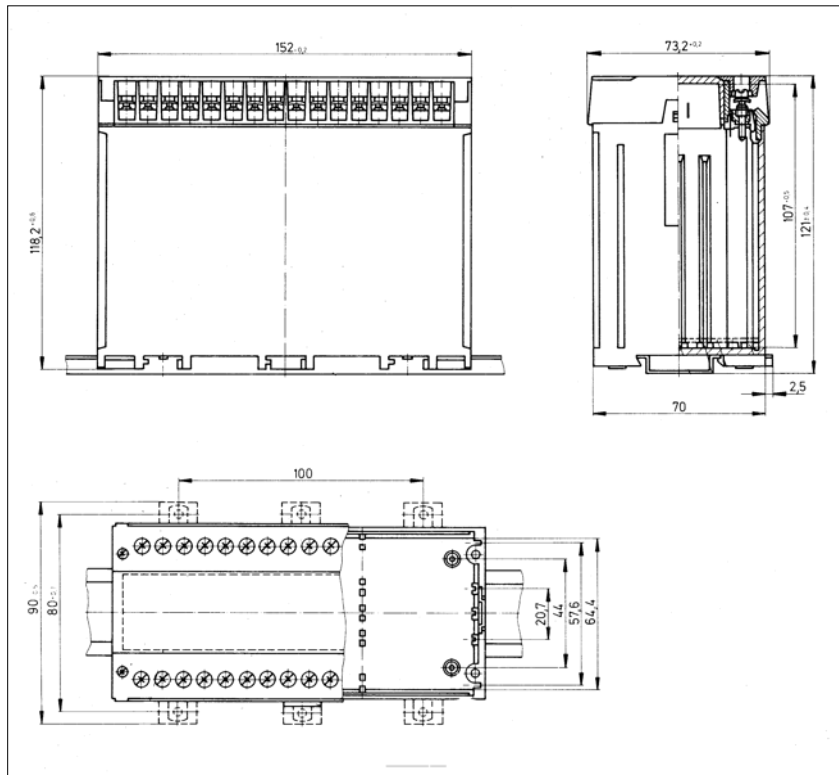

ULSG3 / ULSG6:

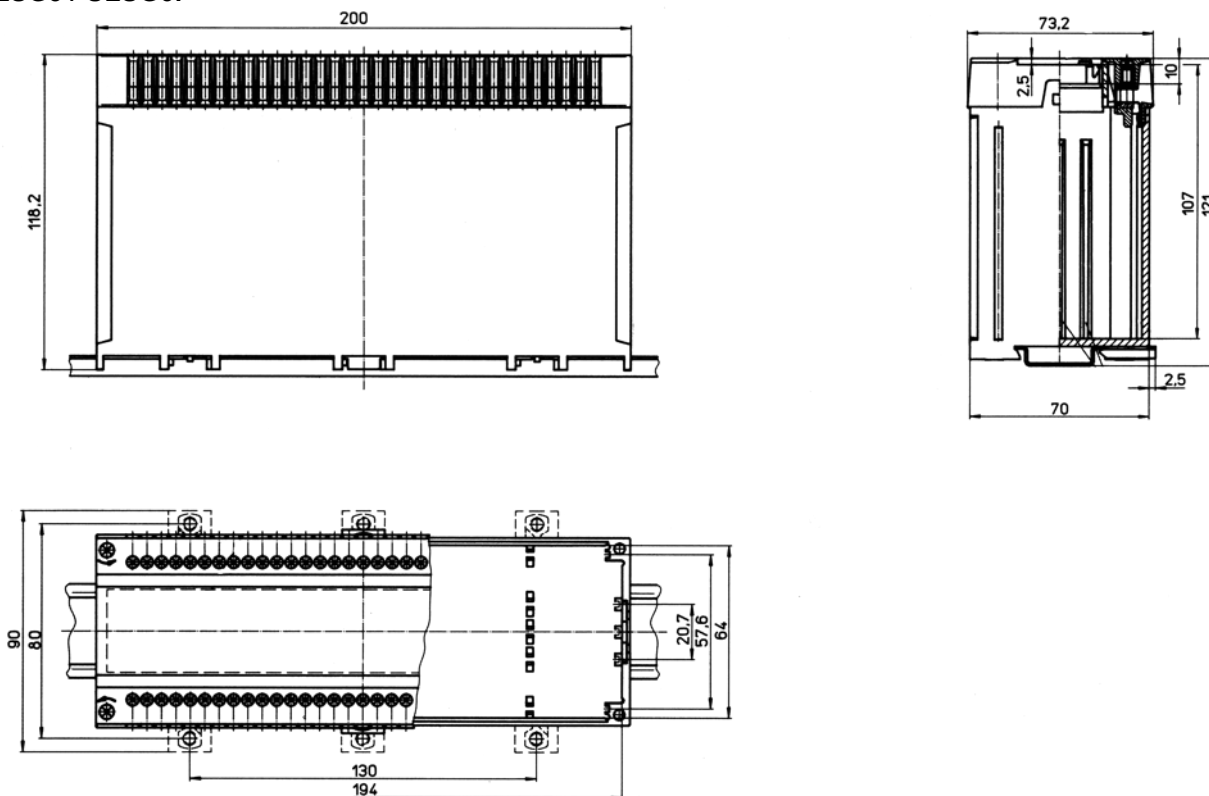

4. Technical Datas

The ULSG... controllers fulfils the power-failure bridging standard of 20 ms specified by EN 60204 and is therefore suitable for supplying the safety light curtain with voltage.

Characteristic data

Safety category	4 according to EN 954-1 and IEC 61496 or EN 61496
Operating modes	- With / without restart interlock (only in conjunction with the light curtain) - With / without contactor / valve control (only in conjunction with the light curtain)
Response time	6 ms

Mechanical data

Housing design	Black insulating material, beige cover
Fastening	Snap-on fastening on a hat rail (DIN EN 50022-35), screw fastening
Weight	ULSG: 1200 g, ULSG DUO: 1400 g, ULSG3: 600 g, ULSG6: 800 g

Operational data

Protection type	IP 20
Protection class	Protective insulation
Ambient operating temperature	-10 to 55 °C
Storage temperature	-25 to 70 °C

Electrical data

Supply voltage	ULSG / ULSGDUO: 230 V AC/50Hz +10% -15%, or 115 V AC/50Hz +10% -15%, or 24 V DC, + 20% - 10% ULSG3/6: 24 V DC, + 20 % - 10 %
Outputs	The output contacts are potential-free, monitored (only in conjunction with the light curtain), force-guided and normally open with a maximum loading capacity of 2 A/250 V AC or 60 V DC, 30 W
Inputs	Contact control and start button: 0 V to 24 V DC ±20% (no extraneous voltage!)
Electrical connection	Plug-in terminal strip
Connection cable	Max. 1,5 mm ²

Service

If you have any questions that cannot be answered by reading this operating manual, please contact us directly.

When calling, please have the following details ready:

- Device designation
- Serial number
- Fault symptoms and description

Fiessler Elektronik GmbH & Co. KG
Buchenteich 14
D-73773 Aichwald

Phone +49-711-919697-0
Fax +49-711-919697-50
E-mail info@fiessler.de

Maintenance

The devices of the series of ULSG... are maintenance-free.

On request by the customer, Fiessler Elektronik GmbH & Co. KG carries out the acceptance test and annual inspections. In addition, seminars providing customers with training in annual inspections are held at regular intervals.

Warranty

The company Fiessler Elektronik GmbH & Co. KG refuses to accept any warranty claims if the device has been opened or if it has been modified.

Returning a unit

If a unit proves defective and needs to be returned, the following details will greatly help us in repairing the fault quickly:

- Exact fault description
 - Has the machine furnished with the light curtain exhibited other faults?
 - Have you noticed any other failures in the past?
 - In which operating mode was the unit last used?

The more precise the fault description, the more efficiently and reliably we will be able to pinpoint and eliminate the fault.

Download area

The latest operating manuals, device descriptions etc. can be downloaded free-of-charge from our homepage.

<http://www.fiessler.de>

Matching light curtains, light grids

Light curtains, light grids

Suitable safety light barriers with blanking functions can comprise, for instance, devices of the ...LCT and ...LVT series. These devices are available as light grids with various beam intervals.



Additional safety products

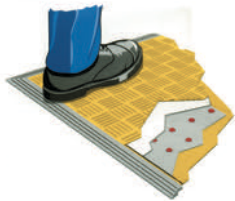

Footmats

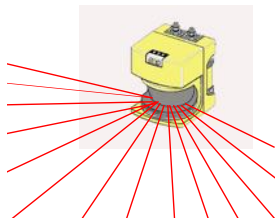

Laser scanners



Parametrizable safety controller FPSC

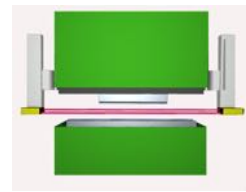

Press brake protection system AKAS



Light curtains for safety, control and measurement

Service

Safety seminars and integration support by our service team.

Certification

A quality management system was introduced at an early stage to guarantee the high quality of Fiessler safety equipment. Fiessler Elektronik is certified according to DIN ISO 9001. The company's own electromagnetic compatibility laboratory tests products on a regular basis. All safety equipment complies with national and European standards. Development takes place in consultation with the relevant trade associations. Certification is received followed rigorous tests by the Technical Inspection Board.



Recognition

by Baden Württemberg's ministry of economy of outstanding performance by the innovative AKAS safety system.



Fiessler Elektronik GmbH & Co. KG
D-73773 Aichwald

Phone: +49(0)711 -91 96 97-0
Fax: +49(0)711-91 96 97-50
Email: info@fiessler.de
Internet: www.fiessler.de

Represented in all major countries

